

2019

RESIDENTIAL COMPLIANCE MANUAL

FOR THE 2019 BUILDING
ENERGY EFFICIENCY
STANDARDS

TITLE 24, PART 6, AND ASSOCIATED
ADMINISTRATIVE REGULATIONS
IN PART 1.



DECEMBER 2018
CEC-400-2018-017-CMF

CALIFORNIA ENERGY COMMISSION
Edmund G. Brown Jr., Governor

CALIFORNIA ENERGY COMMISSION

Robert B. Weisenmiller, Ph.D.
Chair

Commissioners

Karen Douglas, J.D.
Andrew McAllister
David Hochschild
Janea A. Scott

Payam Bozorgchami, P.E.
Larry Froess, P.E.
Project Managers

Christopher Meyer
Manager
Building Standards Office

David Ashuckian, P.E.
Deputy Director
Efficiency Division

Drew Bohan
Executive Director

This page intentionally left blank.

Acknowledgments

The Building Energy Efficiency Standards (Energy Standards) were first adopted and put into effect in 1978 and have been updated periodically in the intervening years. The Energy Standards are a unique California asset that have placed the State on the forefront of energy efficiency, sustainability, energy independence, and climate change issues, and have provided a template for national standards within the United States as well as for other countries around the globe. They have benefitted from the conscientious involvement and enduring commitment to the public good of many persons and organizations along the way. The 2019 Energy Standards development and adoption process continues a long-standing practice of maintaining the Standards with technical rigor, challenging but achievable design and construction practices, public engagement, and full consideration of the views of stakeholders.

2019 is a major step towards meeting the Zero Net Energy (ZNE) goal by the year 2020 and is the last of three updates to move California toward achieving that goal.

The 2019 Energy Standards revision and the supporting documents were conceptualized, evaluated and justified through the excellent work of Energy Commission staff and consultants working under contract to the Energy Commission, supported by the utility-organized Codes and Standards Enhancement (CASE) Initiative, and shaped by the participation of over 150 stakeholders and the contribution of over 1,300 formal public comments.

We would like to acknowledge Commissioner Andrew McAllister and his adviser, Martha Brooks, P.E. for their unwavering leadership throughout the standards development. Payam Bozorgchami, P.E., who served as the project manager and senior engineer; Bill Pennington, Special Advisor to the Efficiency Division, who provided overall guidance and contributed to the technical content of the Standards documents; Mazi Shirakh, P.E., who served as the senior engineer and senior technical lead for solar photovoltaic standards; Christopher Meyer, who served as the Manager for the Buildings Standards Office; Peter Strait, who served as the supervisor for the Standards Development Unit; Todd Ferris, who served as the supervisor for the Standards Tools Unit, Rebecca Westmore, Matt Chalmers, Jacqueline Moore and Galen Lemei, who provided legal counsel; and technical staff contributors of the Building Standards office including Mark Alatorre, P.E.; Courtney Jones; Larry Froess, P.E.; Simon Lee P.E; Jeff Miller, P.E; Ronald Balneg; Adrian Ownby; Dee Anne Ross; Michael Shewmaker; Alexis Smith; Danny Tam; Gabriel Taylor, P.E.; RJ Wichert; Thao Chau; Ingrid Neumann; The Standards Outreach and Education Unit under the supervision of Christopher Olvera; Andrea Bailey; Amie Brousseau; Paula David; Kelly Morairty; Javier Perez; Daniel Wong, P.E. The Standards Compliance Office, Joe Loyer; Rashid Mir, P.E; Lea Haro who served as the supervisor of the Compliance and Enforcement Unit; Judy Roberson Veronica Olvera; and Tav Commins; Energy Commission editors office managed by Sandy Louey and including Carol Robinson; Amber Beck; Albert Lundeen; Lana McAllister;

Edward Ortiz; and Michael Ward, and the Energy Commission Hotline staff and Web Team.

Key Energy Commission and CASE consultants included NORESKO, Bruce Wilcox, Benya Lighting Design, Frontier Energy, McHugh Energy, Energy Solutions. The CASE Initiative is supported by a consortium of California utility providers which includes the Pacific Gas and Electric Company, Southern California Edison Company, San Diego Gas and Electric Company, Southern California Gas Company, the Sacramento Metropolitan Utility District, and the Los Angeles Department of Water and Power.

Abstract

The Building Energy Efficiency Standards were first adopted in 1976 and have been updated periodically since then as directed by statute. In 1975 the Department of Housing and Community Development adopted rudimentary energy conservation standards under their State Housing Law authority that were a precursor to the first generation of the Standards. However, the Warren-Alquist Act was passed one year earlier with explicit direction to the Energy Commission (formally titled the State Energy Resources Conservation and Development Commission) to adopt and implement the Standards. The Energy Commission's statute created separate authority and specific direction regarding what the Standards are to address, what criteria are to be met in developing the Standards, and what implementation tools, aids, and technical assistance are to be provided.

The Standards contain energy and water efficiency requirements (and indoor air quality requirements) for newly constructed buildings, additions to existing buildings, and alterations to existing buildings. Public Resources Code Sections 25402 subdivisions (a)-(b) and 25402.1 emphasize the importance of building design and construction flexibility by requiring the Energy Commission to establish performance standards, in the form of an "energy budget" in terms of the energy consumption per square foot of floor space. For this reason, the Standards include both a prescriptive option, allowing builders to comply by using methods known to be efficient, and a performance option, allowing builders complete freedom in their designs provided the building achieves the same overall efficiency as an equivalent building using the prescriptive option. Reference Appendices are adopted along with the Standards that contain data and other information that helps builders comply with the Standards.

The 2019 update to the Building Energy Efficiency Standards focuses on several key areas to improve the energy efficiency of newly constructed buildings and additions and alterations to existing buildings. The most significant efficiency improvements to the residential Standards include the introduction of photovoltaic into the prescriptive package, improvements for attics, walls, water heating, and lighting. The most significant efficiency improvements to the nonresidential Standards include alignment with the ASHRAE 90.1 2017 national standards. The 2019 Standards also include changes made throughout all of its sections to improve the clarity, consistency, and readability of the regulatory language.

Public Resources Code Section 25402.1 also requires the Energy Commission to support the performance standards with compliance tools for builders and building designers. The Alternative Calculation Method (ACM) Approval Manual adopted by regulation as an appendix of the Standards establishes requirements for input, output and calculational uniformity in the computer programs used to demonstrate compliance with the Standards. From this, the Energy Commission develops and makes publicly available free, public domain building modeling software in order to enable compliance based on modeling of building efficiency and performance. The

ACM Approval Manual also includes provisions for private firms seeking to develop compliance software for approval by the Energy Commission, which further encourages flexibility and innovation.

The Standards are conceptually divided into three basic sets. First, there is a basic set of mandatory requirements that apply to all buildings. Second, there is a set of performance standards – the energy budgets – that vary by climate zone (of which there are 16 in California) and building type; thus the Standards are tailored to local conditions, and provide flexibility in how energy efficiency in buildings can be achieved. Finally, the third set constitutes an alternative to the performance standards, which is a set of prescriptive packages that provide a recipe or a checklist compliance approach.

Keywords:

California Energy Commission	Mandatory	Envelope Insulation
California Building Code	Prescriptive	HVAC
California Building Energy Efficiency Standards	Performance	Building Commissioning
	Time Dependent	Process Load
Title 24, Part 6	Valuation	Refrigeration
2016 Building Energy Efficiency Standards	TDV	Data Center
	Ducts in Conditioned Spaces	Exhaust
Residential	High Performance Attics	Compressed Air
Nonresidential	High Performance Walls	Acceptance Testing
Newly Constructed	High Efficacy Lighting	Data Collection
Additions and Alterations to Existing Buildings	Water Heating	Cool Roof
	Windows	On-site Renewable

Links to Chapters

Chapter 1	Introduction
Chapter 2	Compliance and Enforcement
Chapter 3	Building Envelope
Chapter 4	Building HVAC
Chapter 5	Water Heating
Chapter 6	Lighting
Chapter 7	PV, Battery Storage, and Solar Ready
Chapter 8	Performance Method
Chapter 9	Additions, Alterations, and Repairs
Appendix A	Compliance Documents
Appendix B	Climate Zones
Appendix C	FAQs on PV, Community Solar, Battery Storage
Appendix D	Eligibility Criteria for Radiant Barriers
Appendix E	Natural Gas Appliance Testing Standards
Appendix F	Field Verified Zonally Controlled Systems
Appendix G	Verification of Existing Home Features
Appendix H	Demand Responsive Controls

Table of Contents

- 1. Introduction 1
 - 1.1 Related Documents 1
 - 1.2 The Technical Chapters 2
 - 1.3 Why California Needs Building Energy Efficiency Standards 3
 - 1.3.1 Energy Savings 3
 - 1.3.2 Electricity Reliability and Demand 3
 - 1.3.3 Comfort 3
 - 1.3.4 Economics 4
 - 1.3.5 Environment 4
 - 1.3.6 Global Warming 4
 - 1.3.7 The Warren-Alquist Act 5
 - 1.4 What’s New for 2019 5
 - 1.4.1 Mandatory Measures: 5
 - 1.4.2 Prescriptive Compliance: 6
 - 1.4.3 Performance Compliance: 6
 - 1.4.4 Additions and Alterations: 6
 - 1.5 Scope and Application 7
 - 1.5.1 Building Types 7
 - 1.5.2 Explanation of Terms 9
 - 1.5.3 Building Orientation 10
 - 1.5.4 Historical Buildings 10
 - 1.5.5 Exempt Buildings 13
 - 1.5.6 Building Systems Covered 14
 - 1.5.7 Additions, Alterations, and Repairs 14
 - 1.6 Compliance Approaches and Mandatory Measures 18
 - 1.6.1 Approaches 19
 - 1.6.2 Mandatory Measures 19
 - 1.6.3 Prescriptive Approach 19
 - 1.6.4 Performance Approach 20
 - 1.7 Climate Zones 20
 - 1.7.1 Building Location Data 21
 - 1.8 Conditioned Floor Area 22

1.9	Where to Get Help	23
1.9.1	Energy Commission Publications and Support	23
1.9.2	Training Opportunities	25
1.9.3	Energy Consultants	25
1.9.4	Online Videos	26
1.9.5	HERS Raters and Providers	26

1. Introduction

This compliance manual is intended to help plans examiners, inspectors, owners, designers, builders, and energy consultants comply with and enforce California's *2019 Building Energy Efficiency Standards* (Energy Standards) for low-rise residential buildings. The lighting, domestic hot water, and indoor air quality requirements in this compliance manual also apply to high-rise residential buildings. The manual is written as a reference and an instructional guide and can be helpful for anyone that is directly or indirectly involved in the design and construction of energy-efficient low-rise residential buildings.

The compliance manual has nine chapters:

Chapter 1 introduces the Energy Standards and discusses the application and scope of the standards for low-rise residences.

Chapter 2 analyzes the compliance and enforcement process, including design and preparation of compliance documentation through field verification and diagnostic testing.

Chapter 3 details the building envelope.

Chapter 4 discusses heating, ventilation, and air-conditioning (HVAC) systems.

Chapter 5 outlines water-heating systems requirements, including the requirements for swimming pool systems.

Chapter 6 looks at requirements for hardwired interior lighting and for outdoor lighting permanently attached to the building.

Chapter 7 examines photovoltaics, battery storage systems, and shared solar electric systems or community-shared battery system compliance option and solar-ready requirements for low-rise residential buildings.

Chapter 8 outlines the performance approach to compliance.

Chapter 9 goes over additions, alterations, and repairs.

1.1 Related Documents

This compliance manual supplements four other related documents that are available from the California Energy Commission. These are:

- A. *The 2019 Building Energy Efficiency Standards, Title 24, Part 6* (Energy Standards). This compliance manual supplements and explains California's energy efficiency standards for buildings; it does not replace them. Readers should have a copy of the Energy Standards to refer to while reading this manual, as well as a copy of the *2019 Reference Appendices*.
- B. 2019 Reference Appendices – The reference appendices have three main subsections: Reference Joint Appendices, Reference Residential Appendices, and Reference Nonresidential Appendices:
 1. The 2019 Reference Joint Appendices contain information common to both residential and nonresidential buildings including, but not limited to,

definitions, climate zone information, weather data, assembly properties, qualification requirements for high-efficacy light sources, compliance documentation registration procedures, qualification requirements for photovoltaic systems, and qualification requirements for battery storage systems.

2. The *2019 Reference Residential Appendices* contain information for residential buildings only. The Reference Residential Appendices contain Home Energy Rating System (HERS) field verification and/or diagnostic testing procedures for HVAC equipment, air distribution ducts, and quality insulation installation.
 3. The *2019 Reference Nonresidential Appendices* contain information for nonresidential buildings only. The reference nonresidential appendices contain HERS field verification and diagnostic testing procedures for HVAC equipment and air distribution ducts, acceptance testing procedures, and luminaire power default values.
- C. *The 2019 Residential Alternative Calculation Method (ACMs or Compliance Software) Approval Manual. The 2019 Residential ACM Approval Manual* describes the process for certifying and decertifying the compliance software programs.
- D. *The 2019 Residential Alternative Calculation Method Reference Manual* lays out the technical rules for implementing the 2019 performance compliance path in software programs.

Material from related documents is not repeated in this compliance manual; rather, it is referenced. If you are using the electronic version of this compliance manual, there are hyperlinks throughout the manual that will take you directly to the document that is referenced.

1.2 The Technical Chapters

Each of the five technical chapters (Chapters 3 through 7) begins with an overview, followed by a presentation of a specific topic in each subsection. For the building envelope, subsections include fenestration, opaque surfaces (walls, floors, and roofs), air leakage and infiltration, radiant barriers, cool roofs, and quality insulation installation (QII) verification. For HVAC, the subsections include heating equipment, cooling equipment, air distribution and fans, controls, indoor air quality, alternative systems, refrigerant charge, and verification. For water heating, subsections include equipment efficiencies and distribution systems. Lighting subsections include high-efficacy lighting, light-emitting diode (LED) lighting, switching devices and controls, and recessed luminaires. Mandatory measures and prescriptive requirements (defined in Section 1.6 of this chapter) are described within each subsection or component. For photovoltaics, the subsections include qualification requirements for photovoltaic systems, battery storage systems, shared solar electric system, or community shared battery system compliance option and solar-ready requirements for low-rise residential buildings. Chapter 8 describes the computer performance approach. Chapter 9 covers requirements for additions and alterations. Chapter 2,

although not a technical chapter, covers important compliance and enforcement topics.

Each technical chapter or subsection also has a compliance options section. The compliance options section includes information on how to design a building that goes beyond the prescriptive energy efficiency requirements and mandatory energy efficiency measures. Compliance options are used for compliance credit through the performance approach. There are also design recommendations for which no compliance credit is offered. However, following the recommendations will significantly impact building energy use or peak demand.

Table 1-1: Compliance Options vs. Design Recommendations

<i>Compliance Options</i>	<i>Design Recommendations, such as interior fenestration shading devices</i>
Credit offered through the performance approach	No credit, but may still impact energy or demand.

1.3 Why California Needs Building Energy Efficiency Standards

Energy efficiency reduces energy costs, increases reliability and availability of electricity, improves building occupant comfort, and reduces impacts to the environment, making the Energy Standards important and necessary for California's energy future.

1.3.1 Energy Savings

Reducing energy use benefits everyone. Homeowners save money, Californians have a more secure and healthy economy, the environment is less negatively impacted, and the state electrical system can operate in a more stable manner. The 2019 Energy Standards (for residential and nonresidential buildings) are expected to reduce the growth in electricity use and reduce the growth in natural gas use.

1.3.2 Electricity Reliability and Demand

Buildings are one of the major contributors to electricity demand. During the 2000-2001 California electricity crisis and the East Coast blackout in the summer of 2003, Energy Commission staff learned that the electric distribution network is fragile and system overloads caused by excessive demand from buildings can create unstable conditions. Furthermore, resulting blackouts can seriously disrupt business and cost the economy billions of dollars.

Since the California electricity crisis, the Energy Commission has placed increasing emphasis on demand reduction.

1.3.3 Comfort

Comfort is an important benefit of energy-efficient homes. Energy-efficient houses are well-insulated, are less drafty, and use high-performance windows and/or shading to reduce solar gains and heat loss. Poorly designed building envelopes

result in houses that are less comfortable. Even with oversized heating and cooling systems, comfort cannot be achieved in older, poorly insulated, and leaky homes.

1.3.4 Economics

For the homeowner, energy efficiency helps ensure that a home is affordable now and into the future. Banks and other financial institutions recognize the effect of energy efficiency through energy-efficient mortgages; they look at the total cost of owning the home, including paying the utility bills. If the utility bills are lower, lenders can qualify borrowers for a larger loan.

From a larger perspective, the less California depends on depletable fossil resources such as natural gas, coal, and oil, the stronger and more stable the economy will remain in the face of energy cost increases. A cost-effective investment in energy efficiency helps everyone. In many ways, it is far more cost-effective for the people of California to invest in saving energy than it is to invest in building new power plants.

1.3.5 Environment

In many parts of the world, energy use has led to oil spills, acid rain, smog, and other forms of environmental pollution that have ruined the natural beauty people seek to enjoy. California is not immune to these problems, but appliance standards, building standards, and utility programs that promote efficiency and conservation help maintain environmental quality. Other benefits include reduced destruction of natural habitats, which helps protect animals, plants, and natural systems.

1.3.6 Global Warming

Burning fossil fuels contributes greatly to global warming; carbon dioxide is being added to an atmosphere already containing 35 percent more than it did two centuries ago. Carbon dioxide and other greenhouse gases create an insulating layer around the Earth that leads to global climate change. Energy Commission research shows that most sectors of the state economy face significant risk from climate change, including water resources (from reduced snowpack), agriculture, forests, and the natural habitats of several indigenous plants and animals.

Scientists recommend that actions be taken to reduce emissions of carbon dioxide and other greenhouse gases. While adding scrubbers to power plants and catalytic converters to cars reduces other emissions, they do not limit the carbon dioxide emitted into the atmosphere. Using energy efficiently is a far-reaching strategy that can make an important contribution to reducing greenhouse gases.

The National Academy of Sciences has urged the United States to follow California's lead on such efforts, saying that conservation and efficiency should be the chief element in energy and global warming policy. Its first efficiency recommendation was simple: Adopt nationwide energy-efficient building codes. Energy conservation will not only increase comfort levels and save homeowners money, it will play a vital role in creating and maintaining a healthy environment.

The Energy Standards are expected to have a significant impact on reducing greenhouse gas and other air emissions. Carbon dioxide (CO₂), one of the more prevalent greenhouse gases, would be reduced.

1.3.7 The Warren-Alquist Act

Section 25402 of the Public Resources Code

Section 25402 of the California Public Resources Code (the code) authorizes the Energy Commission to develop and maintain Energy Standards for new buildings. This section of the code, commonly referred to as the Warren-Alquist Act (the act), is direction from the Legislature on the development of Energy Standards in California.

The act created the Energy Commission in 1974 and gave it authority to develop and maintain building energy efficiency standards for new buildings. The act directs the Energy Commission to “prescribe, by regulation, lighting, insulation, climate control system, and other building design and construction standards which increase the efficiency in the use of energy for new residential and new nonresidential buildings.”

The act also requires that the Energy Standards be cost-effective “when taken in their entirety and amortized over the economic life of the structure,” and it requires that the Energy Commission periodically update the standards and develop manuals to support them. The act directs local building permit jurisdictions to withhold permits until the building satisfies the Energy Standards.

The Public Resources Code, amended through Senate Bill 5X (Sher, Chapter 7, Statutes of 2001), expands the authority of the Energy Commission to develop and maintain standards for outdoor lighting and signs.

1.4 What’s New for 2019

The most significant change in the *2019 Building Energy Efficiency Standards* affecting residential buildings is the introduction of photovoltaic requirements in the prescriptive standards. There are also significant changes in requirements related to indoor air quality requirements..

The determining factor for whether natural gas is available for newly constructed buildings is if a gas service line can be connected to the site without a gas main extension. For additions and alterations, natural gas is available if a gas service line is connected to the existing building.

Other changes for residential buildings include:

1.4.1 Mandatory Measures:

- A. Walls with 2x6 framing require R-20 insulation (if wood-framed) or 0.071 maximum U-factor (§150.0(c)2).
- B. Fan efficacy requirements change to 0.45 W/CFM for gas furnaces and remain at 0.58 W/CFM for systems that are not gas furnaces (single zone and zonally controlled systems (§150.0(c)13B and C).
- C. Modifications to the indoor air quality requirements of American Society of

Heating, Refrigerating, and Air-conditioning Engineers (ASHRAE) 62.2 are included for various building and dwelling unit configurations such as horizontally attached buildings, or central ventilation systems (§150.0(o)1-(o)2).

- D. Minimum efficiency reporting value (MERV) 13 (or equivalent) filters are required for heating/cooling systems and ventilation systems (§150.0(m)12).
- E. New fan efficacy requirement for small-duct high-velocity forced-air systems (§150.0(m)13D).

1.4.2 Prescriptive Compliance:

- A. Adding a prescriptive table (150.1-B) for multifamily buildings (§150.1(c)).
- B. Removing the attic/roof Option A with above-deck insulation (§150.1(c)1A).
- C. Required wall U-factors in Climate Zones 1-5 and 9-16 are changed from 0.051 to 0.048 in single-family buildings; Climate Zones 6-7 remain at 0.065 (§150.1(c)1B).
- D. Added a U-factor requirement for doors (§150.1(c)5).
- E. Quality insulation installation (QII) is now a prescriptive requirement for all single-family buildings in all climate zones, and multifamily buildings in all climate zones except Climate Zone 7 (§150.1(c)1E).
- F. Added prescriptive options for heat pump water heaters for newly constructed buildings, addition, and alterations (§150.1(c)8, §150.2(a)1D, and §150.2(b)1H).
- G. New solar electric generation photovoltaic requirement (§150.1(c)14).
- H. New fan efficacy requirements of 0.45 W/CFM for gas furnaces.

1.4.3 Performance Compliance:

All compliance software programs approved by the Energy Commission use the same compliance engine as the public domain software. The technical details and information about how the energy budget is determined are included in the *2019 Residential Alternative Compliance Manual (ACM) Reference Manual*.

Compliance requires meeting two components of an Energy Design Rating (EDR): (1) an energy efficiency design rating and (2) a solar electric generation and demand flexibility design rating (§150.1(b)1). For more information, see Chapter 8.

1.4.4 Additions and Alterations:

- A. Changes to the prescriptive requirement for continuous insulation on an existing wall with wood siding; if siding is not removed, only cavity insulation is required (§150.2(a)1).
- B. The prescriptive requirement for quality insulation installation (QII) is not required for additions that are 700 square feet or less (§150.2(a)1B).
- C. Roof/ceiling insulation and radiant barrier requirements for prescriptive additions with 700 square feet or less follow Option C (R-38 in Climate Zones 1, 11-16, or R-30 and radiant barrier in Climate Zones 2-10) (§150.2(a)1B).

D. More detailed information on additions and alterations is found in Chapter 9.

1.5 Scope and Application

1.5.1 Building Types

Though the Energy Standards apply to nonresidential and residential buildings, this compliance manual addresses only the requirements for low-rise residential buildings. A companion compliance manual addresses the requirements for nonresidential buildings, including hotels, motels, and high-rise residential buildings that are four or more stories high.

- A. **Mixed Low-Rise Residential and Nonresidential Occupancies.** When a building includes both low-rise residential and nonresidential occupancies, the requirements are different depending upon the percentages of the conditioned floor that is occupied by each occupancy type:
1. **Minor Occupancy** (Exception 1 to §100.0(f)). When a residential occupancy occurs in the same building as a nonresidential occupancy, and if one of the occupancies is less than 20 percent of the total conditioned floor area, the smaller occupancy is considered a “minor” occupancy. Under this scenario, optionally, the entire building may be treated as if it is the major occupancy for envelope, HVAC, and water heating. Lighting requirements in §140.6 through §140.8 or §150.0(k) must be met for each occupancy separately. The mandatory measures applicable to the minor occupancy, if different from the major occupancy, would still apply.
 2. **Mixed Occupancy.** When residential occupancy is mixed with a nonresidential occupancy, and if neither occupancy is less than 20 percent of the total conditioned floor area, these occupancies fall under different sets of standards and must be considered separately. Two compliance submittals must be prepared, each using the calculations and forms of the respective standards. Separate compliance for each occupancy, to the respective standards, is an option when one of the occupancies is a minor occupancy, as discussed in the paragraph above.
- B. **The three-story** designation relates to multifamily buildings, since all single-family homes fall under the low-rise residential requirements regardless of the number of stories. An apartment building with three or fewer habitable stories falls under the low-rise residential standards, while an apartment building that has more than three habitable stories falls under the nonresidential standards. High-rise residential dwelling units must still comply with the lighting and water-heating requirements for low-rise residential buildings; for example, the *Nonresidential Compliance Manual* refers to Chapters 5 and 6 of this document.

In multifamily buildings, lighting in common areas is subject to all nonresidential requirements if the common area conditioned floor area (CFA) exceeds 20 percent of the building CFA. Where the common area does not exceed 20 percent of the building CFA, lighting must meet mandatory requirements – a choice of high-efficacy lighting or automatic controls. (See §150.0(k)12.)

- C. The definition of a **habitable story** in the California Building Code (CBC) is used with the Energy Standards. Mezzanines are not counted as separate habitable stories, nor are minor conditioned spaces, such as an enclosed entry stair that leads to an apartment or dwelling unit on the next floor. A habitable story is one that contains space in which people may live or work in reasonable comfort and that has at least 50 percent of the associated volume above grade.
- D. **Live/work buildings** are a special case since they combine residential and nonresidential uses within units. Such buildings are a common form of new construction in San Francisco and some other urban areas of the state. Even though live/work spaces may be used for an office or a studio, they are typically heated and/or cooled like a residential building. For this reason, the residential standards are more suitable and the Energy Commission has made this determination: Either the low-rise or high-rise residential standards apply, depending on the number of habitable stories.

However, lighting in designated workspaces in live/work lofts must comply with the nonresidential prescriptive lighting requirements. See Chapter 5 of the *Nonresidential Compliance Manual* and §140.6 for more information.

Table 1-2: Building Types Covered by the Low-Rise Residential and Nonresidential Standards

<p>Low-Rise Residential Standards (covered in this compliance manual)</p>	<p>Nonresidential Standards (covered by Nonresidential Compliance Manual)</p>
<p>All low-rise residential occupancies including single-family homes, duplexes, garden apartments, and other housing types with three or fewer habitable stories.</p>	<p>All nonresidential CBC occupancies (Group A, B, E, F, H, I, M, S, or U), as well as high-rise residential (Groups R-1 and R-2 with four or more habitable stories), and all hotel and motel occupancies.</p>
<p>Includes:</p> <p>All single-family dwellings of any number of stories (Group R-3)</p> <p>All duplex (two-dwelling) buildings of any number of stories (Group R-3)</p> <p>All multifamily buildings with three or fewer habitable stories (Groups R-1 and R-2)</p> <p>Additions and alterations to all of the above buildings.</p> <p>Lighting requirements for living quarters in high-rise multifamily buildings (more than three stories) and water-heating requirements for high-rise multifamily buildings (more than three stories)</p> <p>Ventilation and filtration (indoor air quality) requirements are similar for single-family and all nontransient multifamily occupancies.</p>	<p>Includes:</p> <p>Offices</p> <p>Retail and wholesale stores</p> <p>Grocery stores</p> <p>Restaurants</p> <p>Assembly and conference areas</p> <p>Industrial work buildings</p> <p>Commercial or industrial storage</p> <p>Schools and churches</p> <p>Theaters</p> <p>Hotels and motels</p> <p>Healthcare facilities</p> <p>Apartment and multifamily buildings with four or more habitable stories (envelope and HVAC requirements)</p> <p>Long-term care facilities (group R-2) with four or more habitable stories</p> <p>Dormitories or other congregate residences, or any building with dormitory-style sleeping quarters, with six or more “guest rooms”</p> <p>Private garages, carports, sheds, and agricultural buildings.</p>

1.5.2 Explanation of Terms

The term *building type* refers to the classification of buildings defined by the CBC and applicable to the requirements of the *Building Energy Efficiency Standards*. This manual is concerned with the Energy Standards that apply to all low-rise residential buildings, which includes all single-family residential and multifamily buildings with three or fewer habitable stories in the entire building. A multifamily building with four or more habitable stories is under the scope of the nonresidential requirements, but the dwelling units must meet the lighting, water-heating, and setback thermostat requirements for low-rise residential buildings. A multifamily building contains multiple dwelling units that share common walls (single-family attached) and may also share common floors or ceilings (apartments).

All residential buildings not in the above low-rise category are covered in the 2019 edition of the Energy Commission's *Nonresidential Compliance Manual*. (See Parts 1.1 and 1.2.)

- A. A **single-family building** is a single dwelling unit of occupancy group R-3, as defined in the CBC, that stands separate from other dwelling units but may have an attached garage.
- B. A **multifamily building** is a dwelling unit of occupancy group R, as defined in the CBC, that shares a common wall and/or floor/ceiling with at least one other dwelling unit. (See Chapter 8 for more information on multifamily energy compliance.) A single-family attached building is a dwelling unit of occupancy group R that shares a common wall with another dwelling unit.
- C. An **addition** to an existing building increases both the conditioned floor area and volume of a building, which can be new construction or added space conditioning to an existing unconditioned space. See Chapter 9 for more information on energy compliance of additions.
- D. An **existing building** is "...a building erected prior to the adoption of [the current] code, or one for which a legal building permit has been issued." (CBC, Part 2)

1.5.3 Building Orientation

Building orientation can affect the energy use of a building, particularly in cooling-dominated climate zones with a high amount of west-facing glass. Some prescriptive requirements and performance modeling inputs for compliance with the Energy Standards require a description of the building orientation.

A. East-Facing

"East-facing is oriented to within 45 degrees of true east, including 45°0'0" south of east (SE), but excluding 45°0'0" north of east (NE)." (§100.1)

B. North-Facing

"North-facing is oriented to within 45 degrees of true north, including 45°0'0" east of north (NE), but excluding 45°0'0" west of north (NW)." (§100.1)

C. South-Facing

"South-facing is oriented to within 45 degrees of true south, including 45°0'0" west of south (SW), but excluding 45°0'0" east of south (SE)." (§100.1)

D. West-Facing

"West-facing is oriented to within 45 degrees of true west, including 45°0'0" due north of west (NW) but excluding 45°0'0" south of west (SW)." (§100.1)

1.5.4 Historical Buildings

Exception 1 to §100.0(a)

Exception 1 to §100.0(a) states that qualified historic buildings, as regulated in the California Historical Building Code (Title 24, Part 8) or California Building Code, Title 24, Part 2, Volume I, Chapter 34, Division II, are not covered by the *Building Energy Efficiency Standards*. Section 140.6(a)3 clarifies that lighting systems in qualified historic buildings are exempt from the lighting power allowances only if they consist solely of historical lighting components or replicas of historical lighting components. If lighting systems in qualified historic buildings contain some historical lighting components or replicas of historical components, combined with other lighting components, only those historical or historical replica components are exempt. All other lighting systems in qualified historic buildings must comply with the *Building Energy Efficiency Standards*.

The California Historical Building Code (CHBC) Section 8-102.1.1 specifies that all nonhistorical additions must comply with the regular code for new construction, including the *Building Energy Efficiency Standards*. CHBC Section 8-901.5 specifies that when new or replacement mechanical, plumbing, and electrical (including lighting) equipment or appliances are added to historic buildings, they should comply with the *Building Energy Efficiency Standards*, including the *Appliance Efficiency Regulations*.

The California State Historical Building Safety Board has final authority in interpreting the requirements of the CHBC and determining to what extent the requirements of the *Building Energy Efficiency Standards* apply to new and replacement equipment and other alterations to qualified historic buildings. In enacting the State Historical Building Code legislation, one of the intents of the Legislature was to encourage energy conservation in alterations to historic buildings (Health and Safety Code Section 18951).

Additional information about the CHBC can be found on the following website:

<http://www.dgs.ca.gov/dsa/AboutUs/shbsb.aspx>

Or contact the SHBSB at (916) 445-7627.

Example 1-1**Question**

Are additions to historic buildings also exempt?

**Answer**

If the addition adjoins the qualified historic building, then the enforcement agency at its discretion may exempt those measures that they determine could damage the historical value of the building. However, “additions which are structurally separated” from the historic building are not exempt from the Energy Efficiency Standards and must comply with building codes, including the Historical Building Code, Title 24, Part 8, Section 8-704.

Example 1-2**Question**

A sunroom addition is designed with no mechanical heating or cooling and a glass sliding door separating it from all existing conditioned space. Under what conditions will the Energy Standards not apply to this addition?



Source: CEC Photographer: Andersen Windows

Answer

The mechanical and envelope requirements of the Energy Standards do not apply if a building inspector determines that the space is unconditioned. Whether conditioned or unconditioned, per §100.0(c)2, the sunroom must still comply with the applicable lighting requirements of §150.0(k). The sunroom is unconditioned if one of the following apply:

- The new space is not provided with heating or cooling (or supply ducts).
- The new space can be closed off from the existing house with weather-stripped doors.
- The addition is not indirectly conditioned space.

A building official may require a sunroom to be conditioned if it appears to be habitable space, in which case the Energy Standards would apply.

1.5.5 Exempt Buildings

The following building types are exempt from the prescriptive and performance standards:

- A. Seasonally occupied agricultural housing limited by state or federal agency contract to occupancy not more than 180 days in any calendar year (Exception 1 to §100.0(e)2D); however, these buildings must comply with the applicable mandatory requirements.
- B. Based on discretion of building officials, temporary buildings, temporary outdoor lighting or temporary lighting in an unconditioned building, or structures erected in response to a natural disaster (Exception 2 to §100.0(a)). These buildings may also be exempt from the mandatory and prescriptive requirements of the Energy Standards.

1.5.6 Building Systems Covered

The low-rise residential standards affect the design of the building envelope; the heating, ventilation and air-conditioning (HVAC) system; the water-heating system; and the lighting system. The Energy Standards do not apply to residential appliances (*Appliance Efficiency Regulations* may apply), elevators or dumbwaiters, or portable lighting systems that are plugged into a wall outlet. Only hardwired lighting is regulated, which includes lighting that is a permanent part of the building.

1.5.7 Additions, Alterations, and Repairs

§100.1(b)

§150.2(a)

§150.2(b)

Additions, alterations, and repairs are common construction projects for California homeowners. The Energy Standards apply to both additions and alterations, but not to repairs. See Chapter 9 for details.

A. Additions are changes to an existing building that increase both conditioned floor area and volume.

Chapter 9 includes detailed guidance on showing compliance for accessory dwelling units and converting an existing space to conditioned space.

B. Alterations that are not additions are changes to the envelope, space-conditioning system, water-heating system, or lighting system of a building.

C. Repairs are the reconstruction or renewal of any part of an existing building for maintenance purposes and are not under the scope of the standards.

Replacement of any component systems (such as reroofing) or equipment for which there are requirements in the Energy Standards is considered an alteration and not a repair.

Example 1-3

Question

The Energy Standards do not specify whether buildings damaged by natural disasters can be reconstructed to the original energy performance specifications. What requirements apply under these circumstances?

Answer

Buildings destroyed or damaged by natural disasters must comply with the energy code requirements in effect when the builder or owner applies for a permit for those portions of the building that are being rebuilt.

Example 1-4

Question

Do the Energy Standards apply to an addition to a manufactured (“mobile”) home?



Source: CEC Photographer: Brian Vahey

Answer

No. Title 25 requirements, not Title 24, govern manufactured homes, including additions to the unit. Jurisdiction in a mobile home park comes under the authority of the Department of Housing and Community Development. Jurisdiction of a mobile home on private property may come under the authority of the local building department.

Example 1-5

Question

Three stories of residential dwelling units are planned over a first story that includes retail and restaurant occupancies. Do the residential apartments need to comply with the residential standards?

Answer

Yes and No. The building envelope and HVAC equipment must comply with the nonresidential (high-rise residential) standards since the structure contains four habitable stories and, as a whole structure, is a high-rise building. The dwelling units, however, must comply with the lighting and water-heating requirements for low-rise residences.

Example 1-6

Question

Does a four-story townhouse need to comply with the low-rise residential standards or the high-rise residential standards?

Answer

It depends on how the townhouse is classified by the enforcement agency. If the enforcement agency classifies the townhouse as a group R-3 occupancy, the low-rise residential standards will apply. If the townhouse is classified by the enforcement agency as another group R occupancy (i.e. group R-2) and all four stories are habitable, the high-rise residential standards will apply. If the enforcement agency classifies the townhouse as a group R-2 occupancy but three or less of the stories are habitable, the low-rise residential standards will apply.

Example 1-7

Question

A 2,100 ft² manager's residence is being constructed as part of a new 14,000 ft² conditioned warehouse building. Which Energy Standards apply?

Answer

The whole building can comply with the nonresidential standards, and the residential unit is not required to comply separately since it is a subordinate occupancy containing less than 20 percent of the total conditioned floor area. However, the residential dwelling unit must meet all low-rise residential mandatory measures, as well as the lighting and water-heating requirements.

Example 1-8

Question

Assume the same scenario as in the previous example, except that the dwelling unit is new and the remainder of the building is existing. Do the residential standards apply?

Answer

Yes. Since 100 percent of the addition being permitted is a low-rise residential occupancy, compliance under the residential standards is required.

Example 1-9

Question

A residence is being moved to a different location. What are the applicable compliance requirements?

Answer

Because this is an existing conditioned space, the requirements applicable to alterations would apply to any alterations being made. The building does not need to show compliance with the current Energy Standards applicable to new buildings or additions.

Example 1-10

Question

A previously conditioned retail space is remodeled to become a residential dwelling. What are the applicable compliance requirements?

Answer

The remodeled dwelling is treated as if it were previously a residential occupancy. In this case, the rules that apply to residential alterations are applied.

Example 1-11

Question

A 10,000 ft², 16-unit motel is constructed with an attached 1,950 ft² manager's residence. What are the applicable compliance requirements?



Source: <http://www2.sjsu.edu/faculty/wooda/calpark.jpeg>

Answer

The manager's unit is less than 20 percent of the total floor area, so compliance of the whole building as the predominant motel occupancy would satisfy the requirements of the Energy Standards. Either the entire building must comply with the nonresidential (high-rise residential and hotel/motel) standards, or the manager's residence must comply with the low-rise residential standards, and the motel occupancy portion of the building must comply with the nonresidential standards.

Example 1-12

Question

A subdivision of detached homes includes several unit types, each of which may be constructed in any orientation. What are the applicable compliance requirements?

Answer

The low-rise residential standards are applied to each building type. All four cardinal orientations may be shown to comply, or each unit in the planned orientation must comply.

Example 1-13

Question

A four-story apartment building has three stories of apartments and a garage on the first floor. What are the applicable compliance requirements?

Answer

For compliance with the Energy Standards, the low-rise residential standards apply since the building has fewer than four habitable stories. However, for other non-energy codes and standards, this may be considered a four-story building.

Example 1-14

Question

If, in Example 1-13 above, there was a small air-conditioned elevator lobby at the garage floor, what would be the applicable compliance requirements?

Answer

Section 100.1 defines a habitable story as a story that contains space in which people may work or live in reasonable comfort, and that has at least 50 percent of the volume therein above grade. The small elevator lobby does not meet this definition for habitable story; therefore, the low-rise residential standards still apply.

Example 1-15

Question

If, in Example 1-13 above, there was a receptionist station in the conditioned elevator lobby at the garage floor. what would be the applicable compliance requirements?

Answer

In this case, the lobby with the receptionist meets the habitable story definition of §100.1; therefore, the building must be considered a high-rise residential occupancy. The building envelope and HVAC equipment must comply with the nonresidential (high-rise residential) standards, and the dwelling units must comply with the lighting and water-heating requirements for low-rise residential buildings.

1.6 Compliance Approaches and Mandatory Measures

In addition to the mandatory measures (Section 1.6.2), the Energy Standards provide two basic methods for complying with low-rise residential energy budgets: the prescriptive approach and the performance approach. The mandatory measures

must be installed with either of these approaches, but mandatory measures may be superseded by more stringent measures under either approach.

1.6.1 Approaches

- A. The **prescriptive approach**, composed of a climate zone-dependent prescriptive package (Section 1.6.3), is less flexible but simpler than the performance approach. Each energy component of the proposed building must meet a prescribed minimum efficiency. The prescriptive approach offers relatively little design flexibility but is easy to use. There is some flexibility for building envelope components. For example, if a portion of a wall does not meet the prescriptive insulation requirement, an area-weighted average of all walls can be used to meet the prescriptive requirement.
- B. The **performance approach** (Section 1.6.4) is more complicated but offers considerable design flexibility. The performance approach uses an approved software program to model a proposed building and compare it to a calculated energy budget. Performance compliance is based on window efficiency and orientation, shading from overhangs, space-conditioning equipment and water-heating system efficiencies, and house configuration. This approach is popular with production builders because it's flexibility and it provides a way to find the most cost-effective solution for complying with the Energy Standards.

For additions and alterations, see Chapter 9 for details of compliance approaches that are available.

1.6.2 Mandatory Measures

With either prescriptive or performance compliance, there are mandatory measures that must always be met. Some deal with infiltration control and lighting; others require minimum insulation levels or equipment efficiencies. New for the *2019 Building Energy Efficiency Standards* are mandatory measures that require R-20 insulation values for 2' x 6' wood-framed walls, air-filtration devices on most ducted mechanical systems, and kitchen range hoods meeting airflow and sound ratings specified in ASHRAE 62.2. For detailed information on these changes, see applicable sections within this manual.

Minimum mandatory levels are sometimes superseded by more stringent prescriptive or performance approach requirements. For example, if mandatory measures specify R-22 ceiling insulation and the prescriptive approach is used, then R-38 ceiling insulation (depending on climate zone) must be installed. Conversely, the mandatory measures may be of a higher efficiency than permitted under the performance approach; in these instances, the higher mandatory levels must be installed. For example, a building may comply using the performance computer modeling only R-7 insulation in a raised floor, but R-19 must be installed because that is the mandatory minimum.

1.6.3 Prescriptive Approach

§150.1(c)

The prescriptive requirements are represented in Table 150.1-A (single family) or 150.1-B (multifamily). The prescriptive approach is the simplest but least flexible compliance path. New in 2019 is a requirement for a PV system. See Chapter 7 for more information on solar generation, community solar, and battery storage.

The prescriptive approach is a set of predefined performance levels for various building components. Each component meets or exceeds the minimum efficiency level specified in Table 150.1-A or 150.1-B and related footnotes in the Energy Standards. In some climate zones, these prescriptive requirements specify that many cooling system types are HERS-tested to verify that they have the correct refrigerant charge.

1.6.4 Performance Approach

The performance approach, also known as the *computer compliance method*, requires that the building meet both an efficiency EDR and a total EDR. (Additions and alterations continue to meet a time-dependent valuation [TDV] energy budget.) The efficiency EDR is the efficiency of the building without the benefits from any solar generation. The total EDR includes the building and the effects of solar generation plus any solar electric generation.

Annual Time-Dependent Valuation (TDV) energy be calculated for the proposed building and compared to the standard TDV energy budget. TDV energy is the “currency” for the performance approach. TDV energy not only considers the type of energy that is used (electricity, gas, or propane), but when it is used. Energy saved during periods when California is likely to have a statewide system peak is worth more than energy saved at times when supply exceeds demand. Reference Joint Appendix JA3 has more information on TDV energy.

The use of Energy Commission-approved software represents the most detailed and sophisticated method of compliance. While this approach requires the most effort, it also provides the greatest flexibility. The programs automatically calculate the energy budget for space conditioning and water heating, and the minimum required PV size to receive credit toward meeting the efficiency EDR. The budget is determined from the standard design, a computer model of the building using prescriptive requirements. The computer software allows manipulation of the proposed building’s energy features to achieve compliance. See Chapter 8 of this manual for more information on the performance method.

1.7 Climate Zones

To standardize calculations and provide a basis for presenting the prescriptive requirements, the Energy Commission has established a set of standard climate data for each of the 16 climate zones. More information is provided in *Reference Joint Appendix JA2* (also included in Appendix B of this document), including a listing of climate zones for all California ZIP codes. *Reference Joint Appendix JA2* gives other climate information, such as design temperatures for sizing HVAC equipment. The climate zone definitions and data are the same for the low-rise residential and the nonresidential standards.

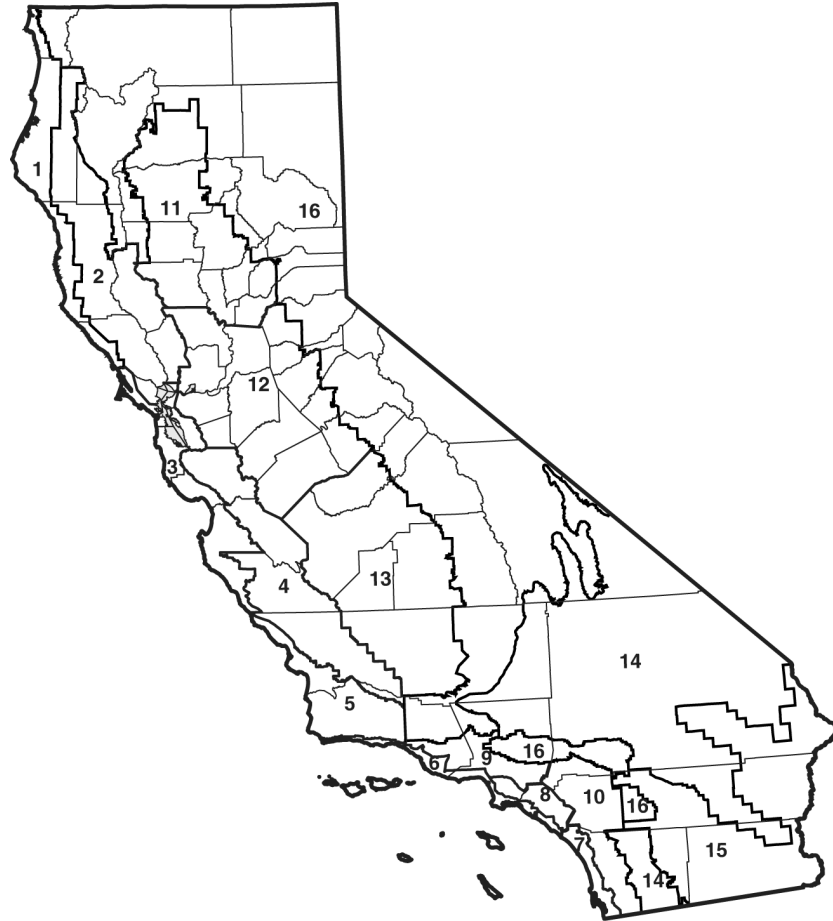
Figure 1-1: California Climate Zones

Source: California Energy Commission

1.7.1 Building Location Data

Building location data refer to specific outdoor design conditions used in calculating heating and cooling loads. Different from the climate zone used for compliance (see *Climate Zones* above), design data include the typically warmest and coolest outdoor temperatures that a building is likely to experience in an average year in a particular location.

Temperatures are from the ASHRAE publication, *SPCDX, Climatic Data for Region X - Arizona, California, Hawaii, Nevada*, May 1982 edition. (See Appendix E.) For heating, the outdoor design temperature is the Winter Median of Extremes. A higher temperature is permitted but no lower than this value. For cooling, the outdoor design temperatures must be the 1.0 percent Summer Design Dry Bulb and the 1.0 percent Wet Bulb columns.

If a building location is not listed, the local enforcement agency may determine the location for which data are available that is closest in its design characteristics to the actual building site.

1.8 Conditioned Floor Area

Conditioned floor area (CFA) is the total floor area (in square feet) of enclosed conditioned space on all floors of a building, as measured at the floor level of the exterior surfaces of exterior walls enclosing the conditioned space (§100.1). This term is also referred to in the Energy Standards simply as the *floor area*.

This is an important value for compliance since annual energy use is divided by this value to obtain the energy budget. In the prescriptive package, the maximum fenestration and west-facing fenestration area requirements are expressed as a percentage of this value.

CFA is calculated from the plan dimensions of the building, including the floor area of all conditioned and indirectly conditioned space on all floors. It includes lofts and mezzanines but does not include covered walkways, open roofed-over areas, porches, pipe trenches, exterior terraces or steps, chimneys, roof overhangs, or parking garages. Unheated basements or closets for central gas-forced air furnaces are also not included, unless shown to be indirectly conditioned.

The floor area of an interior stairway is determined as the CFA beneath the stairs and the tread area of the stairs themselves. See Figure 1-2 below for an example of how CFA is calculated.

Figure 1-2: Total Conditioned Floor Area

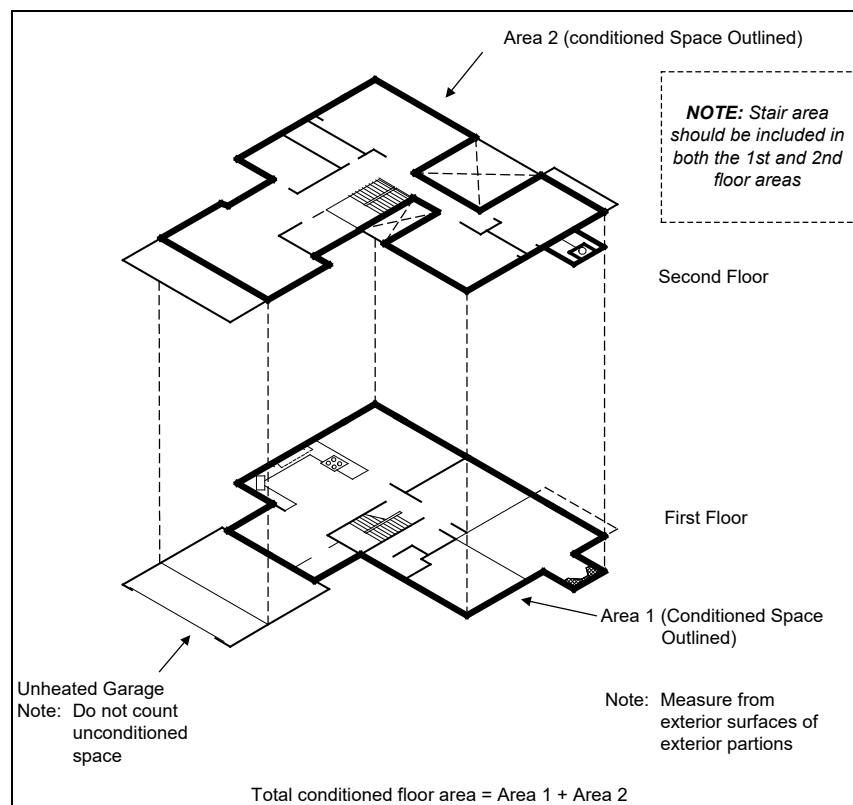

1.9 Where to Get Help

The Energy Commission has several resources to help designers, builders, homeowners, and others understand and apply the Energy Standards.

1.9.1 Energy Commission Publications and Support

A. Telephone Hotline

If the information contained in the Energy Standards or this compliance manual are not sufficient to answer a specific question concerning compliance or enforcement, technical assistance is available from the Energy Standards Hotline.

You can reach the Energy Standards Hotline on weekdays from 8 a.m. – noon and 1 p.m. – 4:30 p.m.:

(800) 772-3300

(916) 654-5106

B. Publications

Publications, including the *2016 Building Energy Efficiency Standards*, the *2016 Reference Appendices*, and the *2016 Residential ACM Approval and Reference Manuals*, and others are available from the Energy Commission's website at <http://www.energy.ca.gov/title24>. Paper copies may also be ordered from:

Publications Unit

California Energy Commission

1516 Ninth Street, MS-13

Sacramento, CA 95814

(916) 654-5200

C. Blueprint

The Energy Commission publishes the *Blueprint*, a newsletter that answers questions and addresses issues related to enforcement and compliance. The *Blueprint* also provides updated information on technical assistance and computer compliance programs and lists training opportunities offered throughout the state. The *Blueprint* is available online at <http://www.energy.ca.gov/efficiency/blueprint>.

Figure 1-3: Energy Commission Blueprint Newsletter



Issue 110 | July – August 2015

BLUEPRINT

California Energy Commission
Efficiency Division

In This Issue

- » 2016 Energy Standards Approved
- » Alpha Versions of CBECC 2016 Now Available
- » CBECC-Com Version 3c
- » Water Heater Energy Factor Reference Guide
- » CALCTP Lighting Controls Certificates of Acceptance
- » Q&A
 - Natural Ventilation
 - Bypass Ducts
 - Heat Pump Water Heating Systems

2016 Energy Standards Approved

The California Energy Commission (Energy Commission) unanimously approved the 2016 Building Energy Efficiency Standards (Energy Standards), except the nonresidential lighting alterations language, at the June 10, 2015 Business Meeting. The 2016 Energy Standards will reduce energy costs, save consumers money, and increase comfort in new and upgraded homes and other buildings.

Single family homes built with the Energy Commission's 2016 Energy Standards will use about 28 percent less energy for lighting, heating, cooling, ventilation, and water heating than those built to the 2013 Energy Standards.

The 2016 Energy Standards, which take effect on January 1, 2017, focus on three key areas: updating residential requirements to move closer to California's zero net energy goals; updating nonresidential and high-rise residential requirements; and improving the clarity and consistency of existing regulations. Based on a 30-year mortgage, the Energy Commission estimates the 2016 Energy Standards will add about \$11 per month for the average home, but will save consumers \$31 on monthly heating, cooling, and lighting bills.

In addition to simplifying the language, other major improvements include:

Residential

- » High performance attics: extra insulation at the roof deck in addition to ceiling insulation will reduce the attic temperature by 35 degrees or more on hot summer days.
- » High performance walls: builders can choose from different wall assemblies to reduce heating and cooling needs in the home year round.
- » Lighting: installation of high quality lighting with controls that nearly halve the energy required for lights in new homes.
- » Water heating: installation of tankless water heaters that reduce energy use by about 35 percent.

Nonresidential

- » Envelope: revision of envelope requirements for all nonresidential and high-rise residential buildings.
- » Lighting: update power for lights to align with the American Society of Heating, Refrigerating, and Air-Conditioning Engineers (ASHRAE) standards. This allows for the installation of newer, more efficient luminaires which are widely available and commonly used for outdoor lighting applications.
- » Elevators: require controls to shut off lights and fans when an elevator is empty. Installation of these controls enables communication with building energy management systems, allowing managers to tailor the building's energy demands and prevent waste.
- » Escalators and moving walkways: require controls on escalators and moving walkways in transit areas to run at a lower, less energy-consuming speed when not in use.
- » Windows and doors: require interlock controls that turn off cooling and heating systems if a door or window is left open for more than five minutes. This allows occupants to take advantage of outside temperatures and save on heating and cooling costs.

For more information about the 2016 Energy Standards, view the **frequently asked questions** and **infographic**.

Please note that Sections 141.0(b)(2), J, K, and L, related to nonresidential lighting alterations, were not adopted at the June 10, 2015 Business Meeting. Adoption of these sec-

D. Appliance Standards

Appliances, as defined by the Energy Commission, include everything from dishwashers and refrigerators to air conditioners and boilers. The performance of some appliances, such as air conditioners, water heaters, and furnaces, is critical to the *Building Energy Efficiency Standards*. The energy efficiency of other appliances, such as refrigerators, dishwashers, and clothes dryers, is important to homeowners but does not affect the *Building Energy Efficiency Standards*, since these are considered home furnishings.

The Energy Commission has comprehensive standards that affect the performance of many appliances. *Appliance Standards* information is available from the Energy Commission website at <http://www.energy.ca.gov/appliances/>.

E. Appliance Directories

The Energy Commission publishes information on the energy efficiency of appliances. Energy Commission-approved directories can be used to determine if appliances meet the mandatory measures and/or the prescriptive requirements. Data may also be used in performance calculations. The Energy Standards Hotline can verify certification of appliances and provide information on appropriate directories.

The complete appliance database (including manufacturer, brand codes, rated efficiencies, and so forth) can be searched from the Energy Commission's website at

<http://www.appliances.energy.ca.gov/>

F. Directory of Certified Insulation Materials

Manufacturers whose insulating materials are certified for sale in California are listed in the Department of Consumer Affairs' *Consumer Guide and Directory of Certified Insulation Material*. Each building department receives a copy of this directory. If an insulating product is not listed in the directory, or if you want to purchase a directory, contact the Department of Consumer Affairs, Bureau of Electronic Appliance and Repair, Home Furnishings and Thermal Insulation (BEARHFTI), at (916) 999-2041.

1.9.2 Training Opportunities

California utilities, organizations of energy consultants, building industry, trade associations, and organizations that serve building officials often sponsor or conduct classes on compliance and enforcement of the Energy Standards. These classes are often listed in the *Blueprint* or posted on the Energy Commission's website at <http://www.energy.ca.gov/title24>.

Energy Code Ace offers free tools, training, and resources to help identify the compliance documents, installation techniques, and standards relevant to building projects in California. Energy Code Ace resources provide fact sheets, trigger sheets, and checklists to help readers understand when Title 24, Part 6 is "triggered" and how to correctly comply when it is.

This program is funded by California utility customers under the auspices of the California Public Utilities Commission and in support of the Energy Commission.

<http://energycodeace.com/>

1.9.3 Energy Consultants

The California Association of Building Energy Consultants (CABEC) maintains a directory of consultants who provide compliance assistance. The listing is available at <http://www.cabec.org>.

1.9.4 Online Videos

The Energy Commission has a series of streaming videos that explain energy efficiency concepts and the application of the Energy Standards. These videos cover topics including plan checking, field inspection, HVAC, HERS, water heating, building envelope, and renewable energy. They can be viewed at <http://www.energyvideos.com>.

1.9.5 HERS Raters and Providers

To comply with the Energy Standards, some buildings require third-party diagnostic testing or field verification of energy-efficient systems or devices. HERS Raters are required to be hired by the builder or building owner to perform this work. Installing contractors may hire the HERS Rater for HVAC change outs only if the homeowner agrees that the installing contractor may do so on his or her behalf. The Energy Commission approves HERS providers who train, certify, and monitor HERS Raters. For a list of the current HERS providers, please go to the Energy Commission website at <http://www.energy.ca.gov/HERS/>. To find a Rater, go to the website of the approved HERS provider available on the Energy Commission's website at the link above, or contact the Energy Standards Hotline at (800) 772-3300 (for calls within California) or (916) 654-5106 for assistance.

Table of Contents

2.	Compliance and Enforcement	1
2.1	Overview.....	1
2.1.1	Manufacturer Certification for Equipment, Products, and Devices.....	1
2.1.2	Compliance Document Registration	2
2.2	Compliance Phases.....	3
2.2.1	Compliance and Enforcement	3
2.2.2	Design Phase	4
2.2.3	Permit Application.....	5
2.2.4	Plan Check	5
2.2.5	Building Permit	6
2.2.6	Construction Phase	7
2.2.7	Enforcement Agency Field Inspection	8
2.2.8	Field Verification and/or Diagnostic Testing.....	10
2.2.9	Approval for Occupancy	11
2.2.10	Occupancy.....	11
2.3	Compliance Documentation.....	12
2.3.1	Building Permit Phase Documentation	13
2.3.2	Certificate of Compliance (CF1R).....	13
2.3.3	Construction Phase Documentation (CF2R).....	14
2.3.4	Field Verification and/or Diagnostic Testing Documentation (CF3R).....	15
2.3.5	Compliance, Operating, Maintenance, and Ventilation Information to Be Provided by Builder	15
2.4	Roles and Responsibilities.....	18
2.4.1	Designer	18
2.4.2	Documentation Author	19
2.4.3	Builder or General Contractor.....	20
2.4.4	Specialty Subcontractors	21
2.4.5	Enforcement Agency	22
2.4.6	HERS Provider	26
2.4.7	HERS Rater.....	27

2.4.8	Third-Party Quality Control Program	30
2.4.9	Owner	31
2.5	HERS Field Verification and Diagnostic Testing	32
2.5.1	Measures Requiring HERS Field Verification and Diagnostic Testing	32
2.5.2	Verification, Testing, and Sampling.....	33
2.5.3	Initial Model Field Verification and Diagnostic Testing	34
2.5.4	Group Sample Field Verification and Diagnostic Testing	35
2.5.5	Resampling, Full Testing, and Corrective Action.....	37
2.5.6	Installer Requirements and HERS Procedures for Alterations	37
2.5.7	For More Information.....	38

2. Compliance and Enforcement

2.1 Overview

The local enforcement agency, typically associated with a city or county government, has primary responsibility for enforcing the California Energy Commission's *Building Energy Efficiency Standards* (Energy Standards). Low-rise residential buildings must obtain a permit from the local enforcement agency before a new building or addition is constructed and before alterations are made to existing buildings. Before a permit is issued, the local enforcement agency examines the plans, specifications and compliance documentation for the proposed building to verify compliance with all applicable codes and standards. The enforcement agency's plan check responsibility is to verify compliance with the Energy Standards, which is done by comparing the certificate of compliance (CF1R) with the plans and specifications for the building.

Once the enforcement agency determines that the proposed building (as represented in the plans and specifications) complies with all applicable codes and standards, a building permit may be issued. Once construction starts, the inspector verifies that the installed building components (HVAC equipment, fenestration, lighting, insulation, and so forth) match the CF1R. After construction is complete, the local enforcement agency performs the final inspection. If the building conforms to the plans and specifications approved during plan check, which includes all applicable certificates of installation (CF2R) and certificates of verification (CF3R).

The compliance and enforcement processes require participation from the architect or building designer, specialty engineers (mechanical, electrical, civil, and so forth), energy consultants, contractors, the owner, third-party inspectors (Home Energy Rating System [HERS] Raters), and others. This chapter describes the overall compliance and enforcement process and responsibilities throughout the permit process.

2.1.1 Manufacturer Certification for Equipment, Products, and Devices

Certain equipment, products, and devices must be certified to the Energy Commission by the manufacturer that it meets requirements under Title 24, Part 6, and associated appendices. The Energy Commission makes no claim that the listed equipment, products, or devices meet the indicated requirements or, if tested, will confirm the indicated results. Inclusion on these lists only confirms only that a manufacturer certification has been submitted to and accepted by the Energy Commission. Additional information about the required information for manufacturers to certify products and for lists of certified products:

http://www.energy.ca.gov/title24/equipment_cert/

In residential buildings, the following must be certified by the manufacturer:

- Airflow measurement apparatus - forced air systems
- Airflow measurement apparatus - ventilation systems
- Air-to-water heat pump systems
- Intermittent mechanical ventilation systems
- Low leakage air-handling unit
- Occupant-controlled smart thermostats
- Demand responsive control systems

2.1.2 Compliance Document Registration

§10-103;
Reference Residential Appendix RA2;
Reference Joint Appendix JA7

Registration of compliance documentation is needed for any construction for which HERS verification is required for compliance. Registration requirements are described in this chapter and throughout this manual. Also, *Reference Residential Appendix RA2 and Reference Joint Appendix JA7* provide detailed descriptions of procedures and responsibilities for registration of CF1R, CF2R, and CF3R.

Registration is needed for all low-rise residential buildings for which compliance requires HERS field verification. For all newly constructed homes, registration is required. There are some exceptions for additions and alterations. When registration is required, compliance documents are electronically submitted to an approved HERS provider data registry (HERS registry) for registration and retention.

Compliance documents submitted to the registry shall be certified by the applicable responsible person (§10-103). The registry will assign a unique registration number to the document(s) when completed and certification (by an electronic signature) is provided by the responsible person. The registry will retain the unique registered document(s) which are available via secure Internet access to authorized users. This allows users to make paper copies of the registered document(s) for purposes such as submittal to the enforcement agency, posting copies in the field for inspections, and providing copies to the building owner. (See Section 2.2.9.)

Authorized users of the registry include energy consultants, builders, building owners, construction contractors and installers, HERS Raters, enforcement agencies, and the Energy Commission. Authorized users are granted read/write access rights to the electronic data associated with their project(s) or responsibilities.

Documents submitted to public agencies for code compliance are public information.

2.2 Compliance Phases

2.2.1 Compliance and Enforcement

Complying with and enforcing the Energy Standards in residential buildings involve many parties. Those involved may include the architect or designer, builder/developer, purchasing agent, general contractor, subcontractor/installer, energy consultant, plan checker, inspector, Realtor, and owner/first occupant. All these parties must communicate and cooperate for the compliance and enforcement process to run efficiently.

The Energy Standards specify detailed reporting requirements intended to provide design, construction, and enforcement parties with the information to ensure that the energy features are properly installed. Each party is accountable to ensure that the features that they are responsible for are correctly installed. This section outlines each phase of the process and the responsibilities and requirements.

The energy compliance documentation has been revised and reorganized. Prescriptive versions of the certificate of compliance (CF1R) have been designed to be used specifically with:

1. Residential Newly Constructed Buildings (CF1R-NCB-01)
2. Residential Additions (CF1R-ADD-01)
3. Residential Alterations (CF1R-ALT-01)
4. Residential HVAC Changeouts (CF1R-ALT-02)
5. Solar (CF1R-SRA-01)

The certificate of installation (CF2R) is separated into:

1. Envelope (CF2R-ENV)
2. Lighting (CF2R-LTG).
3. Mechanical (CF2R-MCH)
4. Plumbing (CF2R-PLB)
5. Solar (CF2R-SPV and CF2R-STH)

These categories and most compliance measures have a separate CF2R form that is specific to a particular installation. CF2R forms also incorporate references to applicable mandatory measures. The HERS certificate of verification (CF3R) forms are categorized and organized in the same way as the CF2R forms. Refer to Appendix A of this manual for more information about the forms and to view samples of the forms. Additional information about the compliance documents will be provided throughout this manual.

When HERS verification is required for compliance, the Energy Standards require all residential energy compliance documents to be registered with a HERS provider data registry. This accomplishes retention of a completed and signed copy of the

submitted energy compliance documentation. To simplify the permit process for HVAC changeouts, §10-103 of the Energy Standards allows the registered CF1R-ALT-02 document to be submitted to an enforcement agency at final inspection and not before obtaining a permit. More details are in Chapter 9 of this manual. Document retention is vital to compliance and enforcement follow-up and other quality assurance follow-up processes that ensure energy savings from installed energy features. Reference Residential Appendix RA2 and Reference Joint Appendix JA7 has more details about document registration procedures building energy code compliance and enforcement process.

2.2.2 Design Phase

§10-103(a)2

This phase sets the stage for the type and style of building to be constructed. In addition to issues concerning zoning, lot orientation, and infrastructure, the overall design and energy features of the building are documented in the construction documents and/or specifications. Parties must ensure that the building complies with the Energy Standards and that the significant features required for compliance are documented on the plans and/or specifications.

During the design process, an energy consultant or other professional will assist the building designer by providing energy compliance documentations that determine the effect of building features being proposed for the design. This helps ensure that the final building design plans and specifications submitted to the enforcement agency will comply with the Energy Standards. Throughout this phase, energy consultants or the documentation author may suggest recommendations or alternatives to help the designer achieve compliance.

The building design plans submitted to the enforcement agency must include the specifications for the building energy features needed to achieve compliance, including insulation levels, window performance, equipment performance, lighting fixture types and controls, exhaust fan performance, envelope sealing, weather-stripping requirements, and any other feature that was used for compliance or is mandatory. The building design plans and specifications must be consistent with respect to the energy efficiency features information on the CF1R submitted to the enforcement agency. Any change in the building plans or specifications, during any phase of design or construction, that changes the energy feature specifications for the design requires recalculation of the building energy compliance. A revised CF1R that is consistent with the updated plans and specifications for the proposed building needs to be issued. If recalculation indicates that the building no longer complies, alternate building features must be selected so that it complies with the Energy Standards.

2.2.3 Permit Application

§10-103(a)2
§10-103(a)1C

When the design is complete, the construction documents are prepared, and other approvals (planning department, water, and so forth) are secured, the owner or contractor applies for a building permit. This is the last step in the planning and design process. At this point, the infrastructure (streets, sewers, water lines, electricity, gas, and so forth) is in place or is being constructed, and construction on the building(s) begins.

To help the enforcement agency verify that the proposed building complies with the Energy Standards, compliance documents are submitted with the building permit application. These documents consist of a CF1R, which is required by the Energy Standards (see §10-103). The length and complexity of the documentation varies depending on factors such as the number of buildings that are being permitted, whether an orientation-independent permit is being requested, and whether the performance approach or the prescriptive approach is being used. An energy consultant who understands the code and is able to help the builder or owner comply with the standards often prepares the certificate of compliance documentation.

The administrative regulations §10-103(a)2 require that documentation be submitted with permit applications that will enable the plans examiner to verify compliance. The forms used to demonstrate compliance must be readily legible and shall conform to a format and informational order and content approved by the Energy Commission. If registration is required, the CF1R that is submitted to the enforcement agency must be a registered copy from an approved HERS Provider data registry.

2.2.4 Plan Check

The registration process requires the builder or designer to submit the certificate of compliance information and an electronic signature to an approved HERS registry to produce a completed, signed, and dated electronic CF1R that is retained by the registry. The CF1R is assigned a unique registration number. Copies of the registered CF1R are available to authorized users of the HERS Provider data registry for use in making electronic or paper copies of the registered document(s) for submitting to the enforcement agency as required.

Local enforcement agencies check plans to ensure that the building design conforms to the Energy Standards. This check includes health and safety requirements, such as fire and structural, and the building energy efficiency requirements. Vague, missing, or incorrect information items on the construction documents are identified by the plans examiner, and the permit applicant is required to make corrections or clarifications and then resubmit revised plans and specifications. Submitting

complete and accurate plans and specifications provides the plans examiner with the information needed to complete the plan check review quickly.

The plan checker verifies that the information on the construction documents is consistent with the requirements specified on the compliance documents. Examples of how the plans examiner will verify that the features detailed on the certificate of compliance forms are specified in the respective sections of the building plans include:

1. Verifying the window and skylight U-Factor and Solar Heat Gain Coefficient (SHGC) values from the CF1R on the structural/architecture plans in a window/skylight schedule, window/skylight legend for the floor plan.
2. Verifying the HVAC equipment and distribution information from the CF1R is clearly documented on the plans, such as SEER, EER, AFUE, HERS measures, and other values necessary to verify compliance.

The enforcement agency should clearly articulate to the builder/designer the acceptable methods of specifying energy features on the building plans for approval.

Since those buying building materials and the construction staff may rely solely on a copy of the approved plans and specifications, it is important that the building design represented on the approved plans and specifications complies with the Energy Standards as specified on the CF1R.

The enforcement agency's plans examiner must also verify that the compliance documents do not contain errors. When the compliance documents are produced by Energy Commission-approved computer software applications, there is less chance that there will be computational errors. The plans examiner must still verify that the design on the plans is consistent with the energy features on the certificate of compliance documents. A list of Energy Commission-approved energy code compliance software applications is at:

<http://www.energy.ca.gov/title24/2019standards/index.html>

Or call the Efficiency Standards Hotline at 1-800-772-3300.

With production homes, where a builder may be constructing several identical houses at roughly the same time, the compliance documentation may be prepared in such a way that a house or model can be constructed in any orientation. The plans examiner shall verify that the home complies facing all four main compass points (north, south, east, and west) on the CF1R form.

2.2.5 Building Permit

After the plans examiner has approved the plans and specifications for the project, the enforcement agency may issue the building permit at the builder's request. Issuing the building permit is the first significant milestone in the compliance and enforcement processes. The building permit is the green light for the contractor to

begin the work. In some cases, the building permits are issued in phases. Sometimes there is a permit for site work and grading before the permit for actual building construction.

2.2.6 Construction Phase

Upon receiving a building permit from the local enforcement agency, the contractor begins construction. The permit requires the contractor to follow the plans and specifications, but often there are variations. Some variations are formalized through change orders. When orders are issued, the permit applicant and the local jurisdiction are responsible to verify that the changes do not compromise compliance with the code. It is clear in some cases such as when a single-glazed, metal frame window is substituted for a high-performance double-pane, vinyl frame window. It may be difficult to determine compliance with changes such as orientation of the house or the location of a window. Field changes that result in noncompliance require enforcement agency approval of revised plans and revised energy compliance documentation to confirm that the building still complies with the Energy Standards.

During construction, the general contractor or specialty subcontractors are required to complete various CF2R. These certificates verify that the contractor is aware of the Energy Standards requirements and that they have followed the Energy Commission-approved procedures for installation, and to identify the energy efficiencies and features of the installed building components. The CF2R's are a collection of energy compliance information forms that apply to each regulated energy feature that may be included in the construction. The certificates are required to be completed by each of the applicable specialty contractors when they install regulated energy features such as windows, water heater and plumbing, HVAC ducts and equipment, lighting, and insulation.

The licensed person responsible for the building construction or for installation of an energy-related feature must ensure their work is done in accordance with the approved plans and specifications for the building. The person must complete and sign a certificate of installation to certify that the installed features, materials, components or manufactured devices for which they are responsible conform to the plans and specifications and the certificate of compliance documents approved by the enforcement agency for the building. A copy of the completed, signed, and dated CF2R must be posted at the building site for review by the enforcement agency in conjunction with requests for final inspection for the building. Copies of the registered CF2R forms shall be provided to the homeowner.

When any HERS verification is required for compliance, all CF2R forms must be registered from an approved HERS Provider data registry. When registration is required, the builder or installing contractor must submit information to an approved

registry to produce a completed, signed and dated electronic CF2R that is retained by the registry for use by authorized users of the registry. After the information to complete the CF2R document is transmitted to the data registry and the form is electronically signed, the CF2R is assigned a registration number. Copies of the unique registered CF2R are made available to authorized users of the registry to make electronic or paper copies of the registered document(s) for submittal to the enforcement agency as required. The builder or installing contractor must provide a copy of the completed, signed, and registered certificate of installation to the HERS Rater and post a copy at the building site for review by the enforcement agency in conjunction with requests for final inspection, and provide copies of the registered CF2R forms to the homeowner.

More information about registering CF2R documents can be found in Reference Residential Appendix RA2 and Reference Joint Appendix JA7.

2.2.7 Enforcement Agency Field Inspection

§10-103(d)

Local enforcement agency representatives inspect new buildings to ensure compliance with the Energy Standards. Field construction changes and noncomplying energy features require parties associated with previous phases to repeat and revise their original energy compliance documents or reinstall building components that meet the building specifications and energy compliance documents.

Enforcement agencies make multiple visits to a building site to verify construction. The first visit is typically made before the slab or the building foundation is poured. The building inspector verifies that the proper reinforcing steel is in place and that necessary wiring and plumbing that will be embedded in the slab meet the requirements of the standards. The inspector should verify features that are to be installed in or under concrete slab floors, such as slab edge insulation or hot water recirculation loops that involve piping that must be installed in the slab. The inspector should also verify the front orientation and floor assembly types (such as slab on grade, raised floor, and others) of the building during this phase of construction. Details of how the inspector should verify these components is in Chapter 3 of this manual.

The second visit occurs after the walls have been framed, and the HVAC equipment and ducting, fenestration, lighting cans, electrical wiring, plumbing, and other services have been constructed or installed. This inspection should be done before insulation is installed to ensure sealing and caulking around windows is completed, and the caulking and sealing of any holes bored through the framing members for installation of hot and cold water piping and electrical wiring. During the rough frame inspection, the inspector should also verify the installation of the high-efficacy

lighting so that the contractor can make any necessary corrections before the final inspection. This avoids having to remove drywall, insulation, and so forth to remove an incandescent can. The inspector should also verify the window/skylight U-factor and SHGC values, the proper sealing/installation of HVAC ducts and duct insulation R-value, the installation of exhaust fan housing and ducting in bathrooms and kitchens (ASHRAE 62.2.), and the installation of a radiant barrier and/or cool roof when required. Details of how the inspector should verify these components will be discussed in further in the respective chapters of this manual.

The third visit is the insulation inspection, which takes place after the wall, ceiling, and floor insulation have been installed. This inspection occurs before the drywall is installed to verify that the insulation R-value matches the CF1R form, and that the insulation has been properly installed without compressions, voids, or gaps. The inspector should verify that insulation is installed correctly around and behind piping, and that all exterior walls are insulated (especially behind obstructing objects like a bathtub). Details of how the inspector should verify these components is in Chapter 3.

The next visit is a drywall inspection, where the inspector verifies that the drywall is installed properly to limit infiltration and exfiltration, especially at locations surrounding lighting cans, HVAC registers and vents, and electrical sockets.

The final inspection is conducted after the walls have been closed and the final electrical and plumbing fixtures are in place. The inspector should verify HVAC efficiency values, water heating efficiency values, exhaust fan and other ventilation system noise level ratings in bathrooms and kitchens (ASHRAE 62.2), filter MERV rating and thickness, exterior lighting and controls, and weather stripping on exterior/demising doors. The inspector will also verify that all required CF2R and CF3R forms have been completed, signed, and registered. Copies of these forms should be provided to the building owner. Details of how the inspector should verify these components will be discussed further in this manual.

The typical enforcement agency inspection sequence can vary from jurisdiction to jurisdiction. It can be difficult for the enforcement agency to verify every energy efficiency measure required to be installed in the building. For example, exterior wall insulation will likely not be installed at the time of the framing inspection. If the enforcement agency does not include the insulation inspection in its field inspection process, the exterior wall insulation would be concealed from an inspector's view at the time of the final inspection.

The certificate(s) of installation and, when required, the certificate(s) of verification are crucial. When inspection of an installed energy feature would be impossible because of subsequent construction, the enforcement agency may require the CF2R for the concealed feature to be posted at the site or made available to the inspector upon completion/installation of the feature. To simplify the inspection, the inspector

would reference the efficiency values and building components specified on the submitted CF2R form to verify compliance with the Energy Standards.

When registration is required, all certificate(s) of installation must be registered through an approved HERS Provider data registry. For all measures requiring field verification, a registered certificate of verification shall also be made available to the building inspector.

2.2.8 Field Verification and/or Diagnostic Testing

Some building features require field verification and/or diagnostic testing completed by a third party-inspector, called a HERS Rater, as a condition for compliance with the standards. The Energy Commission has established the California Home Energy Rating System (HERS) program to train and certify HERS Raters who are considered special inspectors by enforcement agencies. When compliance with the Energy Standards is based on energy features that require third-party (HERS) verification, a certified HERS Rater is required to perform field verification and/or diagnostic testing according to procedures in Reference Residential Appendix RA2 using the protocols in Reference Residential Appendix RA3.

There are mandatory measures, prescriptive measures, and performance credits that require HERS field verification and/or diagnostic testing. Most measures that require verification and testing involve air-conditioning equipment and forced air ducts that deliver conditioned air to the dwelling. Examples of measures requiring HERS verification are refrigerant charge measurement and duct sealing.

The Energy Standards mandate that all newly constructed homes with central HVAC systems have duct sealing (leakage testing), duct system airflow and fan watt draw (and installed HSP/PSPP), and exhaust fans/systems (ASHRAE 62.2.) verified by a HERS Rater when those systems are installed. Details about these measures are in Chapter 4 of this manual.

Additional measures requiring field verification include reduced duct surface area, increased duct R-value, high SEER and EER cooling equipment, and quality installation of insulation. A full list of measures requiring field verification and/or diagnostic testing is in Table RA2-1 of the *2019 Reference Residential Appendices*. The requirements for field verification and/or diagnostic testing apply only when equipment or systems are installed. If a house has no air distribution ducts, then a HERS Rater does not have to test them.

The rater must verify the required features and transmit all required data describing the feature and the results of the verification or diagnostic test to an approved HERS Provider data registry. The rater must also confirm that the installed energy feature being verified is consistent with the requirements for that feature as specified on registered copies of the CF1R approved by the enforcement agency for the dwelling. The person also must confirm the information on the CF2R is consistent with the

CF1R. The test results reported on the CF2R by the person responsible for the installation must be consistent with the test results determined by the rater's diagnostic verification and meet the criteria for compliance with the standards. A copy of the registered CF2R must be posted at the building site for review by the enforcement agency and made available for applicable inspections. A copy of the registered CF2R must also be left in the dwelling for the homeowner at occupancy.

Results from the rater's field verification or diagnostic test are reported to the HERS registry with "pass" or "fail". If the results are "pass", the registry will make a registered copy of the certificate of verification (CF3R) available. A copy of the registered CF3R must be posted at the building site for review by the enforcement agency and made available for all applicable inspections. Copies must be given to the builder and left in the dwelling for the homeowner at occupancy. If results are "fail," that failure must be entered into registry. HERS Providers shall not permit any user of the registry to print or access forms for noncompliance entries unless the CF3R form contains a watermark with the word "FAIL" or "FAILURE." Corrective action shall be taken by the builder or installer on the failed measure. The rater will retest the measure to verify that the corrective action was successful. Once the correction is made, the passing measure shall be entered into the registry.

2.2.9 Approval for Occupancy

In multifamily dwellings of three or more units, the final step is the enforcement agency to issue an occupancy permit so occupants can move in. Single-family homes and duplexes may be approved for occupancy without an occupancy permit being issued. Often a signed-off final inspection serves as an approval for occupancy. When HERS verification is required before occupancy approval, the rater must post a signed and registered CF3R in the field for the building inspector to verify at final inspection. The rater must also provide copies of the registered CF3R to the builder and for the building owner at occupancy. Only registered CF3R documents are allowed for these submittals. Handwritten versions of the CF3R are not allowed.

2.2.10 Occupancy

At the occupancy phase, the enforcement agency shall require the builder to leave all compliance documentation in the building, which includes at a minimum the CF1R and all applicable CF2R forms. When HERS field verification is required, a copy of the registered CF3R must be left on site with the compliance documentation. When registration is required, the CF1R and all required CF2R compliance documentation shall be registered copies. The builder is required to provide the homeowner with a manual that contains instructions for operating and maintaining the features of his or her building efficiently. More details are in Section 2.3.5.

2.3 Compliance Documentation

Compliance documentation includes the forms, reports, and other information that are submitted to the enforcement agency with an application for a building permit. It also includes documentation completed by the contractor or subcontractors to verify that certain systems and equipment have been installed correctly. It may include reports and test results by third-party inspectors (HERS Raters). The compliance documentation is included with a homeowner's manual so that the end user knows what energy features are installed in the house.

Compliance documentation is completed at the building permit phase, the construction phase, the field verification and diagnostic testing phase, and at the final phase. The required forms and documents are in Table 2-1 and described later. When registration is required, all the compliance documentation shall be registered copies from an approved HERS Provider data registry.

Table 2-1: Documentation Requirements, Prescriptive and Performance Compliance Methods

Phase	Method	Documentation Required When Applicable
Building Permit	Performance	CF1R-PRF-E, Certificate of Compliance
	Prescriptive	CF1R-NCB-01-E, Certificate of Compliance
	Prescriptive	CF1R-ADD-01-E, Certificate of Compliance (Additions less than 1,000 ft ²)
	Prescriptive	CF1R-ALT-01-E, Certificate of Compliance (Residential Alterations)
	Prescriptive	CF1R-ALT-02-E, Certificate of Compliance (Alterations to HVAC systems)
	Prescriptive	CF1R-ENV-02-E, Worksheet for area weighted average
	Prescriptive	CF1R-ENV-03-E, Worksheet for solar heat gain coefficient (SHGC)
	Prescriptive	CF1R-ENV-04-E, Worksheet for cool roofs and SRI
	Prescriptive	CF1R-PLB-01-E, Worksheet for hydronic heating systems
	Prescriptive and Performance	CF1R-STH-01-E, Worksheet for OG 100 solar water heating systems
Construction	Prescriptive and Performance	CF2R-E, Certificate of Installation

	Prescriptive and Performance	CF2R-H,HERS Certificate of Installation
Field Verification and/or Diagnostic Testing	Prescriptive and Performance	CF3R-H, Certificate of Verification (HERS Rater)
Field Verification and/or Diagnostic Testing	Performance	CF3R-EXC-20-H, Certificate of Verification for Existing Conditions (HERS Rater) Note: This document must be completed before registering the CF1R-PRF-01-E when using the performance approach for an E+A+A and verification of existing conditions.
A complete list and samples of energy compliance forms is in Appendix A.		

2.3.1 Building Permit Phase Documentation

§10-103(a)

The compliance documentation required at the building permit phase consists of the certificate of compliance (CF1R) on the building plans. Depending on the compliance approach, the energy compliance documentation package may also include the area weighted average calculation worksheet (CF1R-ENV-02-E), the solar heat gain coefficient (SHGC) worksheet (CF1R-ENV-03-E), and the cool roof and SRI worksheet (CF1R-ENV-04-E). Blank copies of these documents are in Appendix A of this manual to use the prescriptive compliance requirements. When the performance approach is used, only the CF1R-STH worksheets are needed since the Energy Commission-approved software performs the calculations and provides the necessary documentation contained in all other worksheets. When the performance approach is used, only the CF1R forms are required on the building plans.

The compliance documentation enables the plans examiner to verify that the building design shown in the plans and specifications complies with the Energy Standards. It enables the field inspector to identify which building features are required for compliance and will be verified in the field.

2.3.2 Certificate of Compliance (CF1R)

The Energy Standards require the certificate of compliance to be incorporated into the plans for the building and submitted to the enforcement agency. The CF1R form identifies the minimum energy performance specifications selected by the building designer or building owner for compliance and may include the results of the heating and cooling load calculations.

To meet the requirement for filing a copy of the CF1R with the building plans, builders/contractors should ask the local enforcement agency for information about

their preferences or requirements for document submittal procedures. Most local jurisdictions may require the CF1R to be embedded in the building design computer-aided drafting (CAD) file for plotting on sheets that are the same size as the plan set sheets of the building design. Thus, the CF1R documentation would be submitted as energy compliance design sheets integral to the entire plan set for the building. Some jurisdictions may allow taping CF1R document sheets to the submitted design drawings for the building. Others may allow attaching 8-½-inch x 11-inch printed CF1R document reports to the submitted design drawing package.

When the prescriptive approach is used for additions and alterations, a shorthand version of the certificate of compliance shall be submitted with the building plans or with the permit application when no plans are required. In these instances, a CF1R-ADD form is required to be submitted for additions, a CF1R-ALT-01 form is required for alterations, and a CF1R-ALT-02 form is required for HVAC changeouts. More details are in Chapter 9.

For low-rise residential buildings for which compliance requires field verification, the CF1R submitted to the enforcement agency must be a registered copy from an approved HERS Provider data registry. More information is in the Reference Residential Appendix RA2 and Reference Joint Appendix JA7.

2.3.3 Construction Phase Documentation (CF2R)

§10-103(a)3

The certificate(s) of installation (CF2R) are separated into envelope (CF2R-ENV), lighting (CF2R-LTG), mechanical (CF2R-MCH), plumbing (CF2R-PLB), and solar (CF2R-PVB and CF2R-STH) categories. Most compliance measures have a separate CF2R form that is specific to a particular installation. The CF2R forms must be completed during the construction or installation phase. The documents must be completed by the applicable contractors responsible for installing regulated energy features such as windows (fenestration), the air distribution ducts and the HVAC equipment, the exhaust fans/ventilation system, the measures that affect building envelope tightness, the lighting system, and the insulation. The CF2R must be posted at the job site in a conspicuous location (for example, in the garage) or kept with the building permit and made available to the enforcement agency upon request.

When field verification and/or diagnostic testing of a feature is required for compliance (as shown in the HERS required certification section of the CF1R), the builder or the builder's subcontractor must perform the initial field verification or diagnostic testing of the installation to confirm and document the applicable CF2R compliance with the standards using the applicable procedures specified in Reference Residential Appendix RA3. The builder, the builder's subcontractor, or authorized representative must submit the CF2R information to an approved

registry. All CF2R information submittals must be done electronically when HERS verification/testing is required.

2.3.4 Field Verification and/or Diagnostic Testing Documentation (CF3R)

§10-103(a)5

Within the Energy Standards, some mandatory measures, some prescriptive requirements, and some measures that may be used for compliance in the performance approach may require field verification and/or diagnostic testing. This testing must be performed by a third-party inspector who is specially trained and independent from the builder or general contractor. The Energy Commission recognizes HERS Raters for this purpose.

When field verification and/or diagnostic testing is required, the rater must complete, register, and sign/certify the certificate of verification (CF3R). The CF3R documents include information about the measurements, tests, and field verification results that were required to be performed. The rater must verify that the requirements for compliance have been met.

The HERS Rater chosen for the project must transmit the CF3R information to an approved HERS Provider data registry. This must be the same registry through which the previous compliance documents (CF1R, CF2R) for the project were registered. The rater used for the project must be certified by the HERS Provider into whose registry the project has been entered. A registered CF3R from the provider that has been signed or certified by the rater is made available to the enforcement agency and to the builder when HERS verification confirms compliance. The builder ensures that the enforcement agency has received the CF3R before the occupancy permit or final inspection.

Raters shall provide a separate registered CF3R form for each house that the rater determines has met the verification or diagnostic requirements for compliance. The rater shall not sign a CF3R for a house that does not have a registered CF2R that has been signed/certified by the installer. If the building was approved as part of a sample group, the CF3R will include additional information that identifies whether the building was a tested or a not tested building from the sample group. The CF3R form for the tested home of a sample group will include the test/verification results, but the not tested homes will not. CF3R forms for not tested homes in a sample group will still have a registration number, date, time, and a watermark of the HERS Provider's seal. Refer to Reference Residential Appendix RA2 for more details on HERS verification and CF3R documentation procedures.

2.3.5 Compliance, Operating, Maintenance, and Ventilation Information to Be Provided by Builder

§10-103(b)

The final documentation in the process is the information that is provided to the homeowner. At the completion of construction and before occupancy, the enforcement agency shall require the builder to leave in the building the applicable completed, signed and dated compliance documentation including, at a minimum, the applicable CF1R forms, CF2R forms, and, if compliance required HERS verification, the applicable CF3R forms. When registration is required, these compliance documents shall be registered copies. In addition to the compliance documentation, the builder must leave in the building operating and maintenance information for all installed features, materials, components, and manufactured devices. The operating and maintenance information must contain the details needed to provide the building owner/occupant with instructions on how to operate the home in an energy-efficient manner that ensures satisfactory indoor air quality and to maintain it so that it will continue to work efficiently. For individually owned units in a multifamily building, the documentation must be provided to the owner of the dwelling unit or to the individual(s) responsible for operating the feature, equipment, or device. Information must be for the appropriate dwelling unit or building. Paper or electronic copies of these documents are acceptable.

Example 2-1

Question

What are the plan checking/field inspection requirements related to the CF-2R?

Answer

The CF2R (certificate of installation) is not submitted with compliance documentation at the time of permit application. It is posted or made available for field inspection after installation. A field inspector should check the equipment that is actually installed against what is listed on the CF2R and compare the CF2R and CF1R for consistent equipment characteristics. The field inspector should do this for all installed building components indicated on a CF2R form (HVAC, fenestration, insulation, water heating, and so forth).

When HERS verification is required for compliance, the field inspector should check the HERS-required verification listings on the CF1R to identify the required installer tests and verify that these tests were performed and documented on the applicable certificate(s) of installation (CF2R).

The enforcement agency may request additional information to verify that the installed efficiency measures are consistent with the approved plans and specifications. When material properties or equipment efficiencies greater than the minimum requirements are shown on the CF1R, the enforcement agency may have procedures for verifying the actual material or equipment specifications. For example, the enforcement agency may require the installer to provide a copy of the applicable page(s) from a directory of certified equipment.

Example 2-2

Question

What happens to the CF2R after the final inspection?

Answer

§10-103(b) requires the builder to leave a copy of the CF2R in the building for the building owner at occupancy.

Example 2-3

Question

As a general contractor, when I have finished building a home, is there a list of materials I am supposed to give to the building owner?

Answer

Section 10-103(b) requires that at final inspection the enforcement agency shall require the builder to leave compliance, operating, maintenance, and ventilation information in the building for the “building owner at occupancy,” which includes the:

1. Certificate of compliance (CF1R).
2. Certificate(s) of installation (CF2R).
3. Certificate(s) of verification (CF3R) if applicable.
4. Operating information for all applicable features, materials, components, and mechanical devices installed in the building.
5. Maintenance information for all applicable features, materials, components, and manufactured devices that require routine maintenance for efficient operation.

Example 2-4

Question

I built some multifamily buildings and have some questions about the information I must provide to the building owner at occupancy (as required by §10-103(b)). Specifically:

If the building is a condominium, can I photocopy the same CF1R information for all units?

When the building is an apartment complex (not individually owned units), who gets the documentation?

If an apartment is converted to condominiums, does each owner/occupant receive copies of the documentation?

Answer

Photocopied information is acceptable. It must be obvious that the CF1R documentation applies to that dwelling unit. The features installed must match the features shown on the certificate(s) of installation (CF2R). If the compliance documentation is for a whole building, a photocopy of the CF1R for that building must be provided. If individual compliance is shown for each unique dwelling unit, a photocopy of the documentation that applies to that dwelling unit must be provided. The copies may be in paper or electronic format.

The documentation and operating information are provided to the individual responsible for operating the feature, equipment, or device (typically the occupant). Maintenance information is provided to the person responsible for maintaining the feature, equipment or device. This is either the owner or a building manager (§10-103(b)).

If, during construction, the building changes from an apartment to condominiums, each owner at occupancy would receive the documentation. If an existing apartment building changes to condominiums at a later date, the documentation requirements are triggered only by a building permit application requiring compliance with the Energy Standards. Changing occupancy does not trigger compliance with the standards.

2.4 Roles and Responsibilities

2.4.1 Designer

5537 and 6737.1 of California Business and Professions Code

The designer is responsible for the overall building design. The designer specifies the building features that determine compliance with the Energy Standards and other applicable building codes. The designer is required to sign the certificate of compliance (CF1R) to certify that the building complies with the Energy Standards.

The designer may personally prepare the documents or may delegate preparation of the energy analysis and certificate of compliance documents to an energy documentation author or energy consultant. If preparation of the compliance documentation is delegated, the designer must remain in charge of the building design specifications, energy calculations, and all building feature information represented on the certificate of compliance. The designer's signature on the certificate of compliance affirms his or her responsibility for the information submitted.

The designer may be an architect, engineer or other California-licensed professional; however, a licensed design professional may not always be required for low-rise residential buildings. *The California Business and Professions Code* allows unlicensed designers to prepare design documentation for wood-framed single-family residential building if the dwellings are no more than two stories high, not counting a possible basement. Two-story, wood-framed multifamily buildings may also be designed by unlicensed designers if the building has four or fewer dwelling

units. For homes that do not require a licensed design professional, the builder may sign the CF1R in the “Responsible Building Designer’s” signature block.

When the designer is a licensed professional, the signature block on the certificate must include the designer's license number. When registration is required, the certificate of compliance must be submitted to an approved HERS Provider data registry. All submittals to the registry must be made electronically.

2.4.2 Documentation Author

§10-103(a)1

The person who designs the building may delegate the energy analysis and preparation of the certificate documentation to a building energy consultant or documentation author. A completed Certificate of Compliance must be submitted to the enforcement agency during the building permit phase. The certificate demonstrates to the enforcement agency plan checker that the building design complies with the Energy Standards. The information submitted on the certificate must be consistent with the building design features in the plans and specifications for the building submitted to the enforcement agency.

The documentation author is not subject to the same limitations and restrictions of the *Business and Professions Code* as is the building designer because the documentation author is not responsible for specification of the building design features. The documentation author may provide the building designer with recommendations for building energy features. If building designer approves the recommendations, the features must be incorporated into the design plans and specification documents submitted to the enforcement agency at plan check. The documentation author’s signature on the certificate of compliance certifies that the documentation is accurate and complete but does not indicate documentation author responsibility for the specification of the features that define the building design. The documentation author provides completed certificate of compliance documents to the building designer, who must sign the certificate before submitting it to the enforcement agency at plan check.

If registration of the certificate of compliance is required, it must be submitted to the registry and signed electronically by both the designer and documentation author before submitting to the enforcement agency. When document registration is required, only registered certificates of compliance that display the registration number assigned to the certificate by an approved HERS registry are acceptable for submittal to the enforcement agency at plan check.

A list of recommended documentation authors is at the California Association of Building Energy Consultants’ (CABEC) website at <http://www.cabec.org>

2.4.3 Builder or General Contractor

Chapter 9 of the *Business and Professions Code* specifies that for that chapter, the term “contractor” is synonymous with the term “builder.” This manual uses “builder” to refer to the general contractor responsible for construction. For production homes, the builder may also be the developer with responsibility for arranging financing, acquiring the land, subdividing the property, securing the necessary land planning approvals, and attending to the other necessary tasks that are required before actual construction. Many production builders are involved in marketing and sales of homes after they are constructed.

During the construction process, the builder or general contractor usually hires specialty subcontractors to provide specific services, such as installing insulation, designing and installing HVAC systems, installing windows and skylights, installing water heating systems, and other services. For homes that do not require a licensed design professional, the builder may sign the CF1R in the “Responsible Building Designer's” signature block.

The builder or general contractor must ensure that certificate(s) of installation (CF2R) are submitted to the enforcement agency by the person(s) responsible for the construction/installation of regulated features, materials, components, or manufactured devices. The builder or general contractor may sign the certificate of installation on behalf of the specialty subcontractors they hire, but the preparation and signature responsibility resides with the specialty subcontractor who provided the installation services. The certificate of installation identifies the installed features, materials, components, or manufactured devices detailed in the plans and specifications, and the certificate(s) of compliance approved by the local enforcement agency. If the installation requires field verification and diagnostic testing by a HERS Rater, the certificate of installation must report the results of the installer's testing of the regulated installations to measure performance. The certificate and the CF2R shall be submitted to an approved HERS registry. A copy of the registered certificate of installation is required to be posted at the building site for review by the enforcement agency in conjunction with requests for final inspection.

When the Energy Standards require registration of the compliance documents, the builder or general contractor must ensure the transmittal/submittal of the required information to an approved HERS registry. The builder or general contractor must arrange for the services of a certified HERS Rater if the certificate of compliance indicates that third-party field verification and diagnostic testing by a rater is required. The builder or general contractor must ensure that a copy of the certificate that was approved by the designer/owner and submitted to the enforcement agency during the permitting phase is transmitted to the registry. The certificate should be made available to the rater who will perform any required field verification and diagnostic testing.

When installation work is complete, the builder or general contractor must ensure that the persons responsible for the installation have transmitted/submitted the required certificate of installation information to the registry. The builder must ensure that the HERS Rater receives a copy of the completed certificate of installation or provide access to the registry that has been registered and signed by the builder or subcontractors responsible for the installation. When registration of the certificate of installation is required, the completed and signed copies that are posted at the building site for review by the enforcement agency, in conjunction with requests for final inspection, are required to be registered copies.

At final inspection, the builder or general contractor is required to leave in the building all applicable completed, signed, dated, and registered (when applicable) compliance documents for the building owner at occupancy. Such information must, at a minimum, include information indicated on the following forms: certificate of compliance (CF1R); certificate(s) of installation (CF2R); and for buildings for which compliance requires HERS field verification, certificate(s) of verification (CF3R). These forms must be in paper or electronic format and must conform to the applicable requirements of §10-103(a).

2.4.4 Specialty Subcontractors

Specialty subcontractors provide the builder with services from specific building construction trades for installation of features such as wall and ceiling insulation, windows, HVAC systems and/or duct systems, water heating systems, and plumbing systems, and these subcontractors may perform other trade-specific specialty services during building construction. The builder is responsible for all aspects of building construction and has the authority to complete and sign/certify all sections of the required certificate(s) of installation (CF2R) forms. The licensed specialty subcontractor, however, should be expected to complete and sign/certify all applicable certificate(s) of installation that document the completion of the work they have performed. The subcontractor's responsibility for documentation should include providing a registered (when applicable) and signed copy of all applicable CF2R's to the builder and posting a registered (when applicable) and signed copy of all applicable CF2Rs at the building site for review by the enforcement agency. The subcontractors should make the registered and signed copies of the applicable installation forms available to the HERS Rater if third-party field verification is required for compliance, as specified on the CF1R.

When the Energy Standards require document registration, all copies of the certificate(s) of installation submitted to the builder, the enforcement agency, and the HERS Rater are required to be registered copies prepared by following the procedures in Reference Residential Appendix RA2, Reference Joint Appendix JA7, and Section 2.3 of this manual.

2.4.5 Enforcement Agency

§10-103

The enforcement agency is the local agency with responsibility and authority to issue building permits and verify compliance with applicable codes and standards. The agency performs several key roles in the compliance and enforcement process.

2.4.5.1 Plan Check

The enforcement agency performs plan check review of the certificate(s) of compliance documentation and of the plans and specifications that define the building design submitted to the enforcement agency at the building permit phase. During plan check, the agency compares certificate of compliance documentation to the plans and specifications for the building design to confirm that the building features are specified consistently in all the submitted documents. If the specification for design features on the certificate of compliance does not conform to the specifications on the designer's submitted plans and specifications for the building, the designer must revise the submitted documents to make the design specification consistent in all documents.

If the certificate of compliance indicates the building complies, and they are consistent with the features on the plans and specifications for the building design, then the plan check process can confirm that the design complies with the building energy code. If the enforcement agency determines that the building design complies with the Energy Standards, in addition to all the other building codes, it may issue a building permit. When the Energy Standards require document registration, the certificate of compliance documentation submitted for a plan check must be a registered document from an approved registry. The one exception is the CF1R-ALT-02-E for HVAC changeouts. If approved by the enforcement agency, permit applicants may use unregistered CF1R-ALT-03-E or CF1R-ALT-04-E documents (dependent upon climate zone) to apply for permits and present the registered CF1R-ALT-02-E to the inspector at the time of the final permit.

2.4.5.2 Construction Inspection

During building construction, the enforcement agency should make several visits to the construction site to verify that the building is being constructed in accordance with the approved plans and specifications and energy compliance documentation. At each site visit, the agency should review any applicable certificate(s) of installation that have been posted or made available with the building permit(s). The enforcement agency should confirm that the energy efficiency features installed in the house are consistent with the requirements given in the plans and specifications for the building approved during plan check, that the installed features are described accurately on the certificate(s) of installation, and that all applicable sections of the

certificate(s) of installation have been signed by the responsible licensed person(s). The enforcement agency shall not approve a dwelling unit until it has received all applicable certificate(s). When the Energy Standards require registration of the energy compliance documents, the certificate(s) of installation documents must be registered with an approved registry.

2.4.5.3 Corroboration of Field Verification and Diagnostic Testing Procedures

As described in Reference Residential Appendix Section RA2.4.4, at its discretion, the enforcement agency may require that field verification and diagnostic testing performed by the builder or subcontractors or the certified HERS Rater must be scheduled to be performed at a time when the enforcement agency's field inspector can observe the verification or test procedures to corroborate the results reported/documented on the certificate(s) of installation (CF2R) and/or the certificate(s) of verification (CF3R).

2.4.5.4 Sampling Within Enforcement Agency Jurisdictions

When sampling is used for HERS verification compliance for newly constructed buildings, all dwellings in a designated sample group must be located within the same enforcement agency jurisdiction and subdivision or multifamily housing development, as specified in Reference Residential Appendix Section RA2.6.3.1

When sampling is used for HERS verification compliance for alterations, the dwellings in a designated sample group are not required to be located within the same enforcement agency jurisdiction. The building owner may choose for the field verification and diagnostic testing to be completed as part of a designated sample group composed of dwelling units for which the same installing company has completed the work that requires field verification and diagnostic testing for compliance, as specified in Reference Residential Appendix Section RA2.8. However, to enable the enforcement agency to schedule testing to accomplish the corroboration described in the previous section, it may choose to require that a separate dwelling unit from the sample group that is located within the respective jurisdiction be tested.

2.4.5.5 Final Approval

The enforcement agency may approve the dwelling at the final inspection phase if the agency field inspector determines that the dwelling conforms to the requirements of the plans and specifications of the building and certificate of compliance documents approved by the enforcement agency at plan check, and meets all other applicable codes and standards requirements. For dwelling units that have used an energy efficiency compliance feature that requires certificate of installation documentation, the enforcement agency shall not approve the dwelling unit until the agency has received a certificate meeting the §10-103(a) requirements that has

been completed, signed, and registered (when applicable) by the builder or subcontractor.

For dwelling units requiring third-party HERS field verification and diagnostic testing for compliance, the enforcement agency shall not approve the dwelling unit until the agency has received a registered copy of the certificate of verification that meets the requirements of §10-103(a) and has been signed and dated by the HERS Rater. The builder must ensure that all such required energy compliance documentation has been completed properly and posted at the job site or submitted to the enforcement agency in conjunction with any of the agency's required inspections. However, the agency, in accordance with §10-103(d), as a prerequisite to approval of the building, must examine all required copies of certificate(s) of installation (CF2R) documentation and certificate(s) of verification (CF3R) documentation posted at the site or made available with the building permits for the required inspections. This confirms that they have been properly prepared and are consistent with the plans and specifications and the certificate of compliance documentation approved by the enforcement agency for the building at plan check.

When an alteration has been performed by a participating Third-Party Quality Control Program (TPQCP) contractor (see Section 2.4.8 of this manual), the enforcement agency may conditionally approve the building based on the certificate of installation (CF2R) if the TPQCP data checking has indicated that the installation complies. However, if subsequent HERS compliance verification procedures determine that resampling, full testing, or corrective action is necessary for such conditionally approved dwellings in the group, the corrective work must be completed. Additional information is in Reference Residential Appendix RA2.4.3, RA2.7, and RA2.8.

2.4.5.6 Corroboration of Information Provided for the Owner/Occupant

At final inspection, the enforcement agency shall require the builder to leave in the building (for the building owner at occupancy) energy compliance, operating, maintenance, and ventilation information documentation as specified by §10-103(b).

Compliance documents for the building shall, at a minimum, include information indicated on forms: certificate of compliance (CF1R), certificate(s) of installation (CF2R), and, for buildings for which compliance requires HERS field verification, certificate(s) of verification (CF3R). These forms shall be copies of the documentation submitted to or approved by the enforcement agency, and the copies must conform to the applicable requirements of §10-103(a).

Operating information shall include instructions on how to operate or maintain the buildings energy features, materials, components, and mechanical devices correctly and efficiently. Such information shall be in a folder or manual that provides all information in §10-103(b). This operating information shall be in paper or electronic

format. For dwelling units, buildings or tenant spaces that are not individually owned and operated, or are centrally operated, such information shall be provided to the person(s) responsible for operating the feature, material, component, or mechanical device installed in the building. This information shall be in paper or electronic format.

Maintenance information shall be provided for all features, materials, components, and manufactured devices that require routine maintenance for efficient operation. Required routine maintenance actions shall be clearly stated and incorporated on a readily accessible label. The label may be limited to identifying, by title and/or publication number, the operation and maintenance manual for that particular model and type of feature, material, component, or manufactured device. For dwelling units, buildings or tenant spaces that are not individually owned and operated, or are centrally operated, such information shall be provided to the person(s) responsible for maintaining the feature, material, component, or mechanical device installed in the building. This information shall be in paper or electronic format.

Ventilation information shall include a description of the quantities of outdoor air that the ventilation system(s) are designed to provide to the conditioned space of the building, and instructions for proper operation and maintenance of the system. For buildings or tenant spaces that are not individually owned and operated, or are centrally operated, such information shall be provided to the person(s) responsible for operating and maintaining the feature, material, component, or mechanical ventilation device installed in the building. This information shall be in paper or electronic format.

Example 2-5

Question

We are an enforcement agency with jurisdiction over the replacement of the outdoor compressor/condenser unit of an HVAC unit (an alteration), and the HVAC contractor who pulled the permit for replacing the unit has requested that we approve the final inspection and close out the permit based only on the certificate of installation (CF2R) for this job. This job requires HERS verification, and I thought it was necessary to receive the HERS Rater's completed and signed certificate of verification (CF3R) before the job could comply as a condition to final approval of the installation. Is there an allowance for compliance based only on the CF2R?

Answer

Yes. The enforcement agency may provide a conditional final approval of the installation based upon the CF2R for alterations jobs only, and only if the installing contractor is an approved Third Party Quality Control Program (TPQCP) installing contractor. The conditional final approval is allowed if TPQCP data checking has scrutinized the diagnostic test data submitted by the approved contractor's diagnostic test for the installation, and such data checking indicates the installation complies as shown on the CF2R.

The permittee is still required to complete all HERS verification procedures and comply with all HERS verification criteria. A CF3R is still required to be submitted to the enforcement agency, builder, and homeowner for the documentation procedure to be complete. If HERS verification of the approved TPQCP contractor's installation work determines that resampling, full testing, or corrective action is necessary to bring the installation into compliance, such work must be completed before issuing the CF3R. Sampling procedures for HERS verification for installation work performed by an approved TPQCP contractor allows for testing of one sample from a designated group of up to 30 dwellings/installations for which the work was performed by the same approved TPQCP installing contractor. Refer to Reference Residential Appendix Sections RA2.4.3, RA2.7 and RA2.8 (and Chapter 9 of this manual) for additional information.

2.4.6 HERS Provider

<http://www.energy.ca.gov/HERS/>

A HERS Provider is an organization that the Energy Commission has approved to administer a HERS program. The provider certifies and trains raters and maintain quality control over the activities performed by HERS Raters who provide third-party field verification and diagnostic testing on installed energy efficiency features in dwellings when required for compliance with the Energy Standards. Visit the Energy Commission website for the list of approved HERS Providers.

The HERS Provider must maintain a database (data registry) that incorporates a website-based user interface that accommodates the needs of the authorized users of the data registry who administer HERS compliance, document registration, and Energy Standards enforcement. The data registry must receive and record information that can adequately identify and track measures that require HERS verification in a specific dwelling, and must have the capability to determine compliance based on the information input from the results of applicable testing or verification procedures reported as input to the data registry for the dwelling. When the requirements for compliance are met, the registry must make available a unique registered certificate for use in complying with document submittal requirements to enforcement agencies, builders, building owners, HERS Raters, and other interested parties. The registry must simplify electronic submittal of the registered certificates to an Energy Commission document repository for retention of the certificates for use in regulations enforcement.

The HERS Provider must make available via phone or Internet communications interface a way for building officials, builders, raters, and other authorized users of the registry to verify the information displayed on copies of the submitted compliance documentation. Refer to Reference Residential Appendices Section RA2.4.2 and Reference Joint Appendix JA7 for additional information.

2.4.7 HERS Rater

The HERS Rater is trained and certified by an Energy Commission-approved HERS Provider to perform the field verification and diagnostic testing that may be required to demonstrate and document compliance with the Energy Standards. Raters receive special training in diagnostic techniques and building science as part of the certification administered by the HERS Providers. Therefore, HERS Raters are considered special inspectors by enforcement agencies and shall demonstrate competence, to the satisfaction of the agency, to conduct the required visual inspections and diagnostic testing of the regulated energy efficiency features installed in the dwelling.

HERS Raters should recognize that some enforcement agencies charge a fee for special inspectors in their jurisdictions. Because they are special inspectors for the enforcement agency, a rater may be disciplined (for example, prohibit a HERS Rater from conducting field verifications/testing in a local jurisdiction) if the agency determines that a rater does not comply with the Energy Standards. Raters may also be required to attain business licenses in some jurisdictions.

If the documentation author who produced the certificate of compliance documentation for the dwelling is not an employee of the builder or subcontractor, the documentation author for the dwelling may also perform the responsibilities of a HERS Rater, provided the documentation author has met the requirements and has been certified, and is associated with an Energy Commission-approved HERS Providers.

If requested to do so by the builder or subcontractor, the rater may help the builder or subcontractor transmit/submit the certificate(s) of installation (CF2R) information to the provider for registration. However, the HERS Rater may not certify the information on a certificate of installation. The builder or subcontractor responsible for the installation must provide the certification/signature to confirm the information submitted to the registry, even if the rater transmitted the data. Refer to Reference Residential Appendix Section RA2.5 and Reference Joint Appendix JA7 for more information.

The HERS Rater conducts the field verification and diagnostic testing of the installed special features when required by the certificate of compliance. The rater must transmit the results of the field verification and diagnostic testing to the HERS registry. The rater must provide to the registry all information required to complete

the certificate(s) of verification form and must submit a certification/signature to the registry. The data registry will make available registered copies of the certificate(s) of verification to the rater, the builder, the enforcement agency, and other authorized users of the registry. Printed copies, electronic or scanned copies, and photocopies of the completed, signed, and registered certificate(s) of verification (CF3R) are allowed for document submittals, subject to verification that the information contained on the copy conforms to the registered document information on file in the HERS registry for the dwelling. A completed, signed, and registered copy of the CF3R must be posted at the building site or made available to the inspector for review by the enforcement agency in conjunction with requests for final inspection for each dwelling unit.

Go to Reference Residential Appendix Section RA2.4.2 for more information.

Example 2-6

Question

Can a certified HERS Rater who does the field verification and completes and signs the CF3R for a dwelling also perform the testing required of the builder or installer to certify compliance with the Title 24, Part 6 installation requirements on the CF2R?

Answer

Yes. This approach is allowed when the HERS Rater is doing field verification for every dwelling (100 percent testing), but it is not allowed when the rater performs verification using a designated sample group of dwellings. When 100 percent testing is used for HERS verification, the builder or the installer may use the information from the rater's verification or diagnostic test results when completing the CF2R. When doing so, builders or installers signing the certification statement on the CF2R are assuming responsibility for the information in the form and are certifying that the installation conforms to all applicable codes and regulations. The rater may not sign the form and cannot be assigned the responsibilities of the builder or installer, as stated on the CF2R form and in regulations.

If the HERS Rater determines that the compliance requirements are not met, the HERS Rater will submit the data of the failed verification/testing into a HERS registry for retention. The builder or installer must make the needed corrections. Once corrections have been made and the rater determines that all compliance requirements are met, the builder or installer may certify the work by completing and signing the applicable section of the CF2R. The HERS Rater can complete the CF3R documentation for the dwelling.

Example 2-7

Question

I heard that there are conflict-of-interest requirements that HERS Raters must abide by when doing field verification and diagnostic testing. What are these requirements?

Answer

Raters are expected to be objective, independent third parties as field verifiers and diagnostic testers. They are special inspectors for local enforcement agencies. By law, raters must be independent entities from the builder or subcontractor installer of the energy efficiency features being tested and verified. They can have no financial interest in the installation of the improvements. Raters cannot be employees of the builder or subcontractor whose work they are verifying. Also, they cannot have a financial interest in the builder's or contractor's business, or advocate or recommend the use of any product or service that they are verifying.

The Energy Commission expects HERS Raters to enter into a contract with the builder (not with subcontractors) to provide independent, third-party diagnostic testing and field verification. The procedures adopted by the Energy Commission call for direct reporting of results to the builder, the HERS Provider, and the building official. Although not recommended by the Energy Commission, a three-party contract among builder, rater and subcontractor is possible, provided that the contract delineates the independent responsibilities of the rater and the responsibilities of a subcontractor to take corrective action in response to deficiencies found by a rater. Such contracts may also establish the role for a subcontractor to serve as administrator for the contract, including scheduling the rater, invoicing, and payment, provided the contract ensures that money paid by the builder to rater can be traced through audit. It is critical that such contractors preserve the rater's independence in carrying out the responsibilities specified in Energy Commission-adopted HERS field verification and diagnostic testing procedures. Even though such contracts do not violate the requirements of the Energy Commission, the closer that the working relationship is between the rater and the subcontractor whose work is being inspected, the greater the potential for compromising the rater's independence.

Compliance cannot be shown using sampling if a three-party contract is used. One hundred percent of homes must be tested by a HERS Rater when a three-party contract is used. Raters must use their own diagnostic equipment and not the installing contractor's equipment when verifying work performed when a three-party contract is used.

(See *Blueprint #66*, pp. 1-2, and *Blueprint #67*, p. 7.)

HERS Providers must provide ongoing monitoring of the propriety and accuracy of raters in the performance of their duties and to respond to complaints about the rater's performance. Where there may be real or perceived compromising of the rater's independence, the provider is responsible for increasing scrutiny of the rater and take action to ensure objective, accurate reporting of diagnostic testing and field verification results, in compliance with Energy Commission-adopted procedures.

Enforcement agencies have authority to require raters to demonstrate their competence to the satisfaction of the building official. When the rater's independence is in question, building officials can prohibit a particular rater from being used in their jurisdiction or disallow practices that the building official believes will compromise the rater's independence. Building officials may require the use of a three-party contract. For additional information please contact the Energy Commission Hotline.

2.4.8 Third-Party Quality Control Program

The Energy Commission may approve Third-party Quality Control Programs (TPQCP) that serve some of the functions of HERS Raters for field verification but do not have the authority to sign compliance documentation as a rater. The programs do the following:

- A. Train installers, participating program installing contractors, installing technicians, and specialty third-party quality control program subcontractors about compliance requirements for measures for which diagnostic testing and field verification is required.
- B. Collect data from participating installers for each installation completed for compliance credit.
- C. Perform data checking analysis of information from diagnostic testing performed on participating TPQCP contractor installation work to evaluate the validity and accuracy of the data and to independently determine whether compliance has been achieved.
- D. Provide direction to the installer to retest and correct problems when data checking determines that compliance has not been achieved.
- E. Require resubmission of data when retesting and correction is directed.
- F. Maintain a database of all data submitted by the participating TPQCP contractor in a format that is acceptable and made available to the Energy Commission upon request.

The HERS Provider must arrange for an independent rater to conduct independent field verifications of the installation work performed by the participating TPQCP contractor and third-party quality control program. If group sampling is used for HERS verification compliance for jobs completed by a participating TPQCP contractor, the sample from the group that is tested for compliance by the rater may be selected from a group composed of up to 30 dwellings for which the same participating contractor has performed the installation. For alterations, the installation work performed by TPQCP contractors may be approved at the enforcement agency's discretion, based upon a properly completed certificate of installation (CF2R) as described in Section 2.4.5, on the condition that if subsequent HERS compliance verification procedures determine that resampling, full testing, or corrective action is necessary for such conditionally approved dwellings in the group, the corrective work must be completed. If the standards require registration of the certificate of installation, the certificate must be a registered copy from a data registry.

Refer to Reference Residential Appendix RA2.4.3, RA2.7, and RA2.8 for additional information.

2.4.9 Owner

Building owner means the owner of the dwelling unit. For production homes, the owner is the person or family that the builder sells the house to. In custom homes and remodels, the owner may be the builder or developer, a general contractor, architect, or engineer.

As part of the compliance process, the owner must receive compliance, operating, maintenance, and ventilation information documents at the time of occupancy. The enforcement agency must require the builder to leave this information in the building for the building owner at occupancy as specified in §10-103(b).

Example 2-8

Question

What is my responsibility with respect to the CF2R (certificate of installation) as (a) an enforcement agency inspector and (b) as a builder?

Answer

(a) The enforcement agency's field inspector verifies that the required CF2R form(s) are filled out completely and in conformance with the requirements of §10-103(d) during applicable site inspections, which includes verifying the CF2R is registered when required by the standards, and confirming that the person responsible for the installation has signed the certificate. Inspectors must verify that the installed features conform to the plans and specifications and the certificate of compliance approved by the enforcement agency.

The CF2R is required to be posted at the job site or kept with the building permit, and must be made available for all applicable inspections. The inspector should verify certificate(s) of installation during the applicable site inspections (for example, verifying the certificates of installation for quality insulation installation, QII, at the framing and insulation inspections). Do not wait until the final inspection to check all CF2R documentation.

(b) The general contractor or his/her agent (for example, the installing contractor) must complete and sign the CF2R form for the work performed. A homeowner acting as the general contractor for a project is authorized to sign the CF2R. The installing contractor should provide the certification since the CF2R certification statement is an installer's assurance to the owner that the work has been completed properly and complies with applicable codes and regulations. The CF2R certification statement and signature indicates that the equipment or feature 1) was installed properly and confirms that the information provided on the form properly identifies the installed building component or equipment, 2) is equivalent or more efficient than required by the approved plans (as indicated on the CF1R), and 3) meets all relevant certification or performance requirements.

Refer to §10-103(a)3 for more information about certificate of installation requirements.

2.5 HERS Field Verification and Diagnostic Testing

This section describes some procedures and requirements for field verification and/or diagnostic testing of energy efficiency features.

Field verification and diagnostic testing are performed by special third-party inspectors called HERS Raters. The Energy Commission has given this responsibility to the raters, who must be specially trained and certified to perform these services. The raters cannot be employees of the builder or contractor whose work they are verifying. Also, they cannot have a financial interest in the builder's or contractor's business, or advocate or recommend the use of any product or service that they are verifying. The training, quality assurance, and general oversight of the raters are conducted by Energy Commission-approved HERS Providers.

2.5.1 Measures Requiring HERS Field Verification and Diagnostic Testing

Field verification and diagnostic testing are required only when certain regulated efficiency measures or equipment features are installed. If such efficiency measures or equipment features are not installed, then field verification and diagnostic testing are not required. For example, if a dwelling that must comply with the standards does not have air distribution ducts, then HERS verification of duct leakage is not required for compliance.

The following features require field verification and/or diagnostic testing:

- a. Duct sealing
- b. Supply duct location, surface area and R-value
- c. Low-leakage ducts in conditioned space
- d. Low-leakage air handlers
- e. Verification of return duct design
- f. Verification of air filter device design, filter MERV rating, and labeling
- g. Verification of bypass duct prohibition
- h. Refrigerant charge in ducted split-system and ducted packaged unit air conditioners and heat pumps, and mini-split systems
- i. Refrigerant fault indicator display (FID)
- j. Verified system airflow
- k. Air handler fan efficacy
- l. Verified energy efficiency ratio (EER)
- m. Verified seasonal energy efficiency ratio (SEER)
- n. Heat Pump Rated Heating Capacity
- o. Maximum rated total cooling capacity
- p. Evaporatively-cooled condensers
- q. Ice storage air conditioners

- r. Continuous whole-building mechanical ventilation airflow
- s. Intermittent whole-building mechanical ventilation airflow
- t. Building envelope air leakage
- u. High-quality insulation installation (QII)
- v. Quality insulation installation for spray polyurethane foam
- w. PV field verification protocol
- x. Kitchen hood HVI listing for airflow and noise (sones)
- y. Verified parallel piping
- z. Central fan integrated ventilation cooling systems
- aa. Whole house fan
- bb. Zonal controls
- cc. Verified compact hot water distribution system
- dd. Verified pipe insulation credit
- ee. Verified drain water heat recovery system
- ff. Verified point of use
- gg. Demand recirculation: manual control
- hh. Demand recirculation: sensor control
- ii. Multiple recirculation loop design for DHW systems serving multiple dwelling units

2.5.2 Verification, Testing, and Sampling

At the builder's option, HERS field verification and diagnostic testing may be completed for each dwelling unit or for a sample of dwelling units. Sampling is permitted only when multiple dwelling units of the same type are constructed within the same subdivision by the same subcontractor. Sampling may also be used for alterations for groups composed of dwellings having the same measure installed that requires HERS verification, and where the same installing contractor has installed the measures. More details are in Reference Residential Appendix Section RA2.6 and RA2.8.

The builder or subcontractor must provide to the rater a copy of the certificate of compliance approved/signed by the principal designer/owner and a copy of the certificate(s) of installation signed/certified by the builder or subcontractors as specified in Reference Residential Appendix Section RA2.5.

When compliance requires document registration, prior to performing field verification and diagnostic testing, the rater must verify that transmittal to the data registry of the CF1R and CF2R information has been completed for each dwelling unit for which compliance requires HERS verification.

For all HERS verification procedures, the rater must confirm that the certificate(s) of installation have been completed as required and that all other information show

compliance consistent with the requirements given in the plans and specifications and certificate of compliance approved by the local enforcement agency.

If field verification and diagnostic testing determines that the requirements for compliance are met, the HERS Rater shall transmit the test results and certification/signature to the data registry. The provider shall make available a registered copy of the completed and signed certificate of verification to the rater, the builder, the enforcement agency, and other approved users of the HERS registry. Printed copies, electronic or scanned copies, and photocopies of the completed, signed and registered certificate of verification shall be allowed for document submittals, subject to verification that the information contained on the copy conforms to the registered document information currently on file in the data registry. A completed, signed and registered copy of the certificate of verification must be posted at the building site or made available for review by the enforcement agency in conjunction with requests for final inspection for each dwelling unit.

The HERS Provider shall make available via phone or Internet a way for building officials, builders, HERS Raters, and other authorized users of the data registry to verify that the information displayed on copies of the submitted certificate(s) conforms to the registered document information on file in the registry for the dwelling unit.

If the builder chooses the sampling option, the procedures in Reference Residential Appendix Sections RA2.6 and RA2.8 must be followed.

2.5.3 Initial Model Field Verification and Diagnostic Testing

The HERS Rater must diagnostically test and field verify the first dwelling unit of each model within a subdivision or multifamily housing development. To be considered the same model, dwelling units must have the same basic floor plan layout, energy design, and compliance features as shown on the certificate of compliance for each dwelling unit. Variations in the basic floor plan layout, energy design, compliance features, zone floor area, or zone volume, that do not change the HERS features to be tested, the heating or cooling capacity of the HVAC unit(s), or the number of HVAC units specified for the dwelling units shall not cause dwelling units to be considered a different model. For multifamily buildings, variations in exterior surface areas caused by location of dwelling units within the building shall not cause dwelling units to be considered a different model.

The initial model testing allows the builder to identify and correct any potential construction flaws or practices in the build out of each model. If field verification and diagnostic testing determines that the requirements for compliance are met, the HERS Rater will transmit the test results to the data registry. The provider will make available a registered copy of the certificate of verification to the rater, the builder, the enforcement agency, and other authorized users of the data registry.

2.5.4 Group Sample Field Verification and Diagnostic Testing

After the initial model field verification and diagnostic testing are completed, the builder or the builder's authorized representative determines which sampling procedure is to be used for the group of dwellings that require HERS field verification. There are two procedures for HERS verification compliance using group sampling: (1) sampling a closed group of up to seven dwellings; and (2) sampling of an open group of up to five dwellings. The group sampling requirements for each procedure will be discussed in this section.

Transmittal/submittal of the certificate(s) of installation information, for at least one dwelling, to the HERS registry is required to open a new group. Additional dwellings may be entered into the registry and included in an "open" group over a specific period, subject to transmittal/submittal of the certificate(s) of installation information to the registry for each additional dwelling. However, the group shall not remain open to receive additional dwellings for a period longer than six months from the earliest date shown on any certificate of installation for a dwelling included in a group. A group may be closed at any time after the group has been opened at the option of the builder or builder's authorized representative. The size of a closed group may range from a minimum of one dwelling to a maximum of seven dwellings. When a group is closed, no additional dwellings shall be added to the group.

- A. Sampling of a closed group of up to seven dwellings requires the following conditions to be met as prerequisite to receiving HERS compliance verification for the group:
1. All the dwelling units in the sample group have been identified. Up to seven dwellings are allowed to be included in a closed sample group.
 2. Installation of all the measures that require HERS verification has been completed in all the dwellings in the group, and registration of the certificate(s) of installation for all the dwellings has been completed.
 3. The group has been classified as a closed group in the data registry.
 4. At the request of the builder or the builder's authorized representative, a rater will randomly select one dwelling unit from the closed sample group for field verification and diagnostic testing. If the dwelling unit meets the compliance requirements, this tested dwelling and each of the other nontested dwellings in the group will receive a registered certificate of verification.
- B. Sampling of an open group of up to five dwellings requires the following conditions to be met as prerequisite to receiving HERS compliance verification for the group:
1. At least one dwelling unit from the sample group has been identified. Up to five dwellings are allowed to be included in an open sample group.

2. Installation of all the measures that require HERS verification shall be completed in all the dwellings. Registration of the certificate(s) of installation for all the dwellings has been completed.
3. At the request of the builder or the builder's authorized representative, a rater will randomly select one dwelling unit from the open sample group for field verification and diagnostic testing. If the dwelling unit meets the compliance requirements, the tested dwelling and each of the other nontested dwellings shall receive a registered certificate of verification. If there are fewer than five dwelling units, the group shall be allowed to remain open and eligible to receive additional dwelling units. Dwelling units entered into the open group after the successful HERS compliance verification of the tested dwelling shall also receive a registered certificate of verification as a nontested dwelling subject to receipt of the registered certificate(s) of installation by the data registry for the dwelling. The group shall be closed when it reaches the limit of five dwellings, when the six-month limit for open groups has been exceeded, or when the builder requests that the group be closed.

The rater must confirm that the certificate(s) of installation have been completed as required and that the installer's diagnostic test results and the certificate(s) of installation show compliance consistent with the certificate of compliance for the dwelling unit.

The rater must diagnostically test and field verify the selected dwelling unit, and enter the test and/or field verification results into the data registry regardless of whether the results indicate a pass or fail. If the test fails, then the failure must be entered into the provider's registry, even if the installer immediately corrects the problem. In addition, any applicable procedures for resampling, full testing, and corrective action must be followed as described in Section 2.5.5 below.

If field verification and diagnostic testing determine that the requirements for compliance are met, the HERS Rater will enter the test results into the data registry. The provider will make available to the rater, the builder, the enforcement agency, and other approved users of the data registry a registered copy of the certificate of verification for the tested dwelling and for all other nontested dwelling units in the group at the time of the sample test. In order not to create confusion by placing test results on nontested dwelling units, the data registry will not report the testing/verification results of the tested home on the certificate of field verification and diagnostic testing for nontested dwelling units in a sample group. The results will be reported only on the CF3R for the tested dwelling unit of the sample group. However, CF3R forms for nontested dwelling units will still have a registration number and date and a watermark of the provider's seal and so forth and will specify the dwelling unit was not tested and is part of a sample group.

The provider must close any open group within six months after the earliest signature date shown on any certificate of installation for a dwelling entered in the group. When such group closure occurs, the provider shall notify the builder that the group has been closed and require that a sample dwelling be selected for field verification and diagnostic testing by a rater if field verification has not yet been conducted on a sample dwelling entered in the group.

2.5.5 Resampling, Full Testing, and Corrective Action

When a failure is encountered during sample testing, the failure must be entered into the data registry for retention by the HERS Rater. Corrective action must then be taken on the failed dwelling unit, and the dwelling unit must subsequently be retested to verify that corrective action was successful and the dwelling complies. Corrective action and retesting on the dwelling unit must be repeated until the testing determines that the dwelling complies and the successful compliance results have been entered into the HERS registry. A registered certificate of verification for the dwelling shall be made available to the rater, the builder, the enforcement agency, and other authorized users of the data registry.

In addition, the rater must resample and test a second randomly selected dwelling within the sample group to assess whether the first failure is unique or if the rest of the dwelling units are likely to have similar failings. Resampling is the procedure that requires testing of additional dwellings within a group when the initial selected sample dwelling from a group fails to comply with verification requirements.

When resampling in a closed group, if the testing of a second randomly selected dwelling in the group confirms that the requirements for compliance credit are met for that unit, then the unit with the initial failure does not indicate failure in the remaining untested units. A copy of the CF3R will be made available for the remaining dwelling units in the group, including the unit in the resample. If the second sample results in a failure, the rater must report the second failure to the data registry. All the nontested units in the group must be individually field verified and diagnostically tested.

Additional information is in Reference Residential Appendix RA2.6.

2.5.6 Installer Requirements and HERS Procedures for Alterations

When compliance for an alteration requires field verification and diagnostic testing by a certified HERS Rater, the building owner may choose for the field verification and diagnostic testing to be completed for each dwelling unit or as part of a designated sample group of dwelling units for which the same installing company has completed work that requires testing and field verification for compliance. The only alterations that will require HERS testing/verification are HVAC changeouts. The building owner or agent of the building owner must complete the applicable

portions of a shorthand version of the certificate of compliance (the CF1R-ALT) form for his or her climate zone. When compliance requires verification, the building owner or agent must arrange for transmittal/submittal of the certificate of compliance information to the data registry, identifying the altered HVAC system and measures that require verification. The building owner must also submit an approved/signed copy of the certificate of compliance to the rater.

When the installation is complete, the person responsible for the performance of the installation must complete the certificate(s) of installation (CF2R). All required certificate(s) of installation must be registered with an approved data registry when field verification and diagnostic testing are required.

After verifying that the certificate of compliance (CF1R-ALT) and all required certificate(s) of installation are completed, signed, and registered, the rater must verify compliance. If group sampling is used for compliance, the sampling procedures described in Reference Residential Appendix RA2.6.3.3 and RA2.8, for sampling of a closed group of up to seven dwellings must be used. It requires that all dwelling units (HVAC systems) within the group have been serviced by the same installing company. The installing company may request a group for sampling that is smaller than seven dwelling units (HVAC systems). Resampling, full testing, and corrective action must be completed, if necessary, as specified by Reference Residential Appendix RA2.6.4.

Whenever the HERS Rater for the group is changed, a new group must be established.

The enforcement agency cannot approve the alteration until the agency has verified completed, signed and registered certificate of compliance (CF1R-ALT), certificate(s) of installation, and certificate(s) of verification documentation for the altered HVAC system. The agency shall also verify that the installing contractor provides copies of all of these forms to the homeowner.

TPQCP, as specified in Reference Residential Appendix RA2.7, may also be used with alterations and must be limited to closed sample group sizes of 30 dwelling units (HVAC systems) or fewer. When a TPQCP is used, the enforcement agency may approve compliance based on the certificate(s) of installation (CF2R), where data checking has indicated that the unit complies, on the condition that if the required HERS verification procedures determine that resampling, full testing, or corrective action is necessary, such work shall be completed.

2.5.7 For More Information

More details on field verification and/or diagnostic testing and the HERS provider data registry are in the *2019 Reference Residential Appendices and 2019 Reference Joint Appendices*, as described below:

1. Reference Joint Appendix JA7 – Data Registry Requirements
2. Reference Residential Appendix RA2 – Residential HERS Verification, Testing, and Documentation Procedures
3. Reference Residential Appendix RA3 – Residential Field Verification and Diagnostic Test Protocols

Example 2-9

Question

Given a multifamily building that has ducted HVAC systems and HERS verified duct leakage verification for all the dwelling units in the building, what is the correct sampling procedure for HERS field verification and diagnostic testing for the air distribution ducts?

Answer

If the builder of a multifamily building chooses to comply using sampling, then the sampling is done using groups composed of dwelling units that have used the same HERS measures for compliance. Dwellings that do not have the same HERS measures specified for compliance are not allowed to be placed in the same HERS sample group. If the whole-building compliance approach has been used, all dwellings in the building have the same HERS features specified. However, if unit-by-unit compliance approach has been used, and all dwellings do not use the same HERS features for compliance, then only the dwellings that have used the same HERS features may be grouped together.

For this example, since duct testing is the only HERS measure specified for all the dwelling units, all the dwelling units in the building can be grouped together for HERS verification requirements. The procedures for assigning dwellings to groups and the HERS verification of a sample from each group must follow the same procedure as for single-family dwellings described in Section 2.5.2 in this chapter and in Reference Residential Appendix RA2. The first dwelling unit for each model floor plan in the building must be verified by the rater before the start of formation of sample groups.

For multifamily buildings, variations in exterior surface areas caused by location of dwelling units within the building do not cause dwelling units to be considered a different model floor plan. When verifying a dwelling unit, all the duct systems associated with every HVAC unit in the dwelling must be tested to determine compliance for that dwelling. After the verification of the first dwelling of each model floor plan is complete, the rater must randomly select a sample dwelling unit from each group of dwellings that have been formed. These samples must be tested according to applicable procedures in Reference Residential Appendix RA3 and documented according to procedures in Reference Residential Appendix RA2. In a sampled dwelling unit that is to be tested to confirm compliance, the duct system associated with every HVAC unit in that dwelling unit must be tested. However, duct systems do not have to be tested in dwelling units that are not selected for sampling (nontested dwelling), provided the dwelling that was tested complies.

If the tested dwelling in the group complies with the verification, the remaining dwellings in the sample group are certified for compliance based on the results of the sample dwelling test result. Testing must be done on every duct system in a dwelling unit, regardless of whether it appears that the HVAC and duct system are in conditioned space. This is akin to a single-family residence with one HVAC unit serving upstairs with ducts in the attic and another serving downstairs with ducts between floors.

Defining duct location as inside or outside for leakage purposes is not described by the locations of walls or the number of stories. The boundary between inside and outside for leakage purposes is defined by the air boundary, typically drywall, between inside and outside. Spaces between floors and spaces in walls (including interior walls) are often outside from an air leakage perspective because they are not sealed effectively to form an air barrier and communicate to the outside.

Duct insulation is not required for ducts in directly conditioned space because there is an expectation that there will be reduced conduction losses for these ducts. To get full credit for ducts in conditioned space, duct leakage must be tested and meet the requirements for duct sealing. In a multifamily building, for compliance credit to be taken for ducts in conditioned space, all the duct systems in the building must be in conditioned space unless compliance is documented for each dwelling unit separately. To meet the mandatory requirements, all HVAC units must have ducts made of UL 181 approved materials (that is, cased coils). Coils enclosed by sheetrock do not meet the mandatory requirements.

Table of Contents

3.	Building Envelope Requirements	1
3.1	Overview	1
3.1.1.	Navigating This Chapter	1
3.2	New Envelope Requirements for 2019	2
3.3	Fenestration (Window/Skylight/Glazed Door) and Opaque Doors	3
3.3.1.	Fenestration Types	3
3.3.1.1	Windows and Glazed Doors	3
3.3.1.2	Opaque Doors	3
3.3.1.3	Skylights and Tubular Daylight Devices	4
3.3.1.4	Fenestration Subcategories	4
3.3.1.5	Fenestration Definitions	4
3.3.2.	Mandatory Requirements §10-111, §10-112, §110.6	7
3.3.2.1	Fenestration Products and Labeling §10-111; §110.6(a)5	7
3.3.2.2	Certified Product Labels: Temporary and Permanent	8
3.3.2.3	Default Label: Temporary	9
3.3.3.	U-Factor and SHGC Ratings §110.6(a), Table 110.6-A, Table 110.6-B	11
3.3.4.	Air Leakage §110.6(a)1, §110.7	16
3.3.5.	Prescriptive Requirements §150.1(c)3, §150.1(c)4, §150.1(c)5, Table 150.1-A and Table 150.1-B	18
3.3.5.1	Fenestration and Opaque Door Prescriptive and Mandatory Exceptions	20
3.3.5.2	Prescriptive Credit for Exterior Shading Devices §150.1(c)4	22
3.3.6	Fenestration in the Performance Approach §150.1(b)	23
3.3.6.1	Fenestration Area and Orientation	23
3.3.6.2	Improved Fenestration Performance	24
3.3.6.3	Fixed Permanent Shading Devices	25
3.3.6.4	Interior Shading Devices	25
3.3.6.5	Dynamic Glazing	25
3.3.6.6	Window Films §150.1(b)	26
3.3.6.7	Bay Windows §150.1(b)	28
3.4	Opaque Envelope	29
3.4.1	Opaque Envelope Definitions	29

3.4.2. Air Sealing and Air Leakage §110.7, §150.0.....	31
3.4.2.1 Joints and Other Openings §110.7.....	31
3.4.2.2 Fireplaces, Decorative Gas Appliances, and Gas Logs §150.0(e).....	33
3.4.3 Roofing Products §10-113, §110.8(i), §150.1(c)11.....	33
3.4.3.1 Product Labels §10-113.....	33
3.4.3.2 Mandatory Requirements.....	36
3.4.3.3 Prescriptive Requirements §150.1(c)11.....	37
3.4.3.4 Compliance and Enforcement.....	37
3.4.4 Radiant Barriers §110.8(j), §150.1(c)2.....	38
3.4.4.1 Mandatory Requirements §110.8(j).....	38
3.4.4.2 Prescriptive Requirements §150.1(c)2, RA4.2.1.....	38
3.4.5 Vapor Retarder §150.0(g) and RA4.5.1.....	41
3.4.5.1 Product Requirements.....	41
3.5 Insulation Products.....	42
3.5.1. Types of Insulation Products.....	44
3.5.1.1 Batt and Blanket.....	44
3.5.1.2 Loose-Fill Insulation.....	45
3.5.1.3 Spray Polyurethane Foam (SPF).....	46
3.5.1.4 Rigid Insulation.....	49
3.5.2. Insulation Product Requirements §110.8(a).....	50
3.5.3 Ceiling and Roof Insulation §110.8(d), §150(a).....	51
3.5.3.1 Loose Fill Insulation in the Attic §150.0(b).....	51
3.5.3.2 Wet Insulation Systems §110.8(h).....	51
3.5.3.3 Recessed Luminaires §150.0(k)1C.....	52
3.5.3.4 Mandatory Requirements.....	52
3.5.3.5 Prescriptive Requirements §150.1(c) and Table 150.1-A.....	53
3.5.4 Wall Insulation.....	61
3.5.4.1 Mandatory Requirements §150.0(c).....	61
3.5.4.2 Prescriptive Requirements (Table 150.1-A).....	62
3.5.5 Raised-Floor Insulation §150.0(d).....	66
3.5.5.1 Mandatory Requirements.....	66
3.5.5.2 Prescriptive Requirements.....	67
3.5.6 Slab Insulation.....	68

3.5.6.1	Mandatory Requirements §150.0(f).....	68
3.5.6.2	Prescriptive Requirements	70
3.5.7	Thermal Mass	71
3.5.8	Quality Insulation Installation (QII) RA 3.5	72
3.5.8.1	Air Barrier RA3.5.2	75
3.6	Opaque Envelope in the Performance Approach	77
3.6.1	Unvented Attics	78
3.6.2	Above-Deck Insulation.....	80
3.6.3	Insulated Roof Tiles	83
3.6.4	Raised Heel, Extension Truss, or Energy Truss	84
3.6.5	Nail Base Insulation Panel.....	85
3.6.6	Advanced Wall Systems and Advanced Framing	86
3.6.7	Metal Framing.....	92
3.6.8	Structural Foam Wall Systems	93
3.6.9	Controlled Ventilation Crawl Space	93
3.6.10	HERS-Verified Reduced Building Air Leakage RA3.8.....	96
3.7	Alternative Construction Assemblies.....	97
3.7.1	Log Homes	97
3.7.2	Straw Bale	99
3.7.3	Structural Insulated Panels (SIPs).....	99
3.7.4	Insulating Concrete Forms (ICF)	101

3. Building Envelope Requirements

3.1 Overview

This chapter covers building envelope features and compliance strategies and highlights the energy code requirements that affect the design of the building envelope for newly constructed low-rise residential buildings. See Chapter 9 for more information on alterations and additions.

The design of envelope components can significantly affect the energy demand needed to meet heating and cooling loads to maintain the desired inside comfort temperature of the building.

Heating and cooling load calculations are used to determine the mechanical system design needed for space heating and cooling.

- **Heating Loads:** The principal components of heating loads are infiltration and conduction losses through building envelope components, including walls, roofs, floors, slabs, windows, and doors.
 - **Example:** A dwelling unit located in Climate Zone 16 typically has a large heating load due to moderate summers, cool temperatures, and snow cover that predominates for more than half of the year.
- **Cooling Loads:** Cooling loads are dominated by solar gains through windows, skylights, and roof/attic assemblies.
 - **Example:** A dwelling unit located in Climate Zone 15 typically has a large cooling load due to extremely hot and dry summers and moderately cold winters.

3.1.1. Navigating This Chapter

This chapter is organized by building envelope component as seen in the Table of Contents.

This chapter includes:

- An overview of changes to building envelope requirements for the 2019 Energy Standards
- A description of fenestration terminology, requirements and labeling, U-factor, solar heat gain coefficient (SHGC) requirements, and credits that can be used under the performance approach
- Description of opaque envelope terminology, requirements related to insulation, roof products, radiant barriers, air barriers, vapor retarders, and attic ventilation
- Compliance approaches for alternative construction assemblies such as log homes, straw bale, structural insulated panels (SIPs) and insulated concrete form (ICF) construction

Role Icons. The content of this chapter applies to multiple roles in the compliance process. The icons shown in Figure 3-1 are used to identify information that is specific to individual roles to help navigate the compliance process.

Figure 3-1: Role Icons

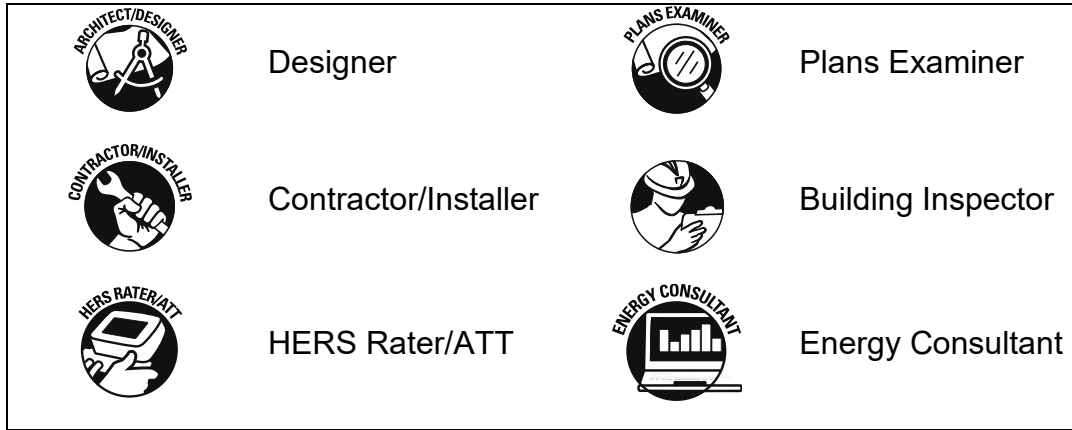

3.2 New Envelope Requirements for 2019



The 2019 *Building Energy Efficiency Standards* for residential buildings include increased efficiencies for several envelope measures, and there are improvements that have been made to better aid the designer, builder, and building official.

<p>MANDATORY §150.0</p>	<ul style="list-style-type: none"> - Mandatory minimum wall U-factor decreased to 0.071 for 2x6 or larger framing (or R-20 for wood framed walls). - Mandatory minimum wall insulation for masonry walls must follow the requirements of Table 150.1-A or 150.1-B.
<p>PRESCRIPTIVE §150.1</p>	<ul style="list-style-type: none"> - A separate prescriptive table for multifamily (Table 150.1-B). - Prescriptive roof insulation level increased to R-19 for Option B, below deck insulation (except multifamily homes in Climate Zones 10 and 16) between the roof rafters. - Prescriptive framed exterior wall U-factor decreased to 0.048 for single-family homes (except in Climate Zones 6 and 7). - Prescriptive mass wall U-factor increased to 0.077 for mass walls with interior insulation. - Prescriptive fenestration U-factor decreased to 0.30. - Prescriptive fenestration SHGC decreased to 0.23. - Prescriptive requirement for opaque exterior doors to have a maximum U-factor of 0.20. When 25% or more of the door opening is glazed, the door is treated as fenestration and must meet fenestration U-factor and SHGC requirements. - Prescriptive requirement for quality insulation installation (QII) (except multifamily homes in Climate Zone 7).

3.3 Fenestration (Window/Skylight/Glazed Door) and Opaque Doors

Fenestration products such as windows, glazed doors, dynamic glazing, window films, and skylights have a significant impact on energy use and heating and cooling loads in a home. The size, orientation, and types of fenestration products can dramatically affect the overall energy performance of a house. Glazing type, orientation, shading, and shading devices not only play a major role in the energy use of a building, but can affect the operation of the lighting system, HVAC system, and comfort of occupants.

Table 3-1: Relevant Sections in the Energy Standards

	MANDATORY	PRESCRIPTIVE	PERFORMANCE
			
Fenestration and Opaque Doors	§10-111, §10-112, §110.6, §150.0(q), Tables 110.6-A and 110.6-B	§150.1(c)3, §150.1(c)4, §150.1(c)5 Table 150.1-A and Table 150.1-B	§150.1(a), §150.1(b)
Limit Air Leakage	§110.7	-	-

3.3.1. Fenestration Types

3.3.1.1 Windows and Glazed Doors

A window is a vertical fenestration product that is an assembled unit consisting of a frame and sash component holding one or more pieces of glazing. Window performance is measured with the U-factor and solar heat gain coefficient (SHGC).

Glazed doors are an exterior door having a glazed area of 25 percent or more of the area of the door. Glazed doors are treated the same as windows and must meet the U-factor and SHGC requirements for windows. Most sliding glass doors, French doors, and some entry doors with large amounts of glazing will meet the definition to be treated as glazed doors.

3.3.1.2 Opaque Doors

When the door has less than 25 percent glazing material, it is considered an opaque door and is subject to the door U-factor requirements. Doors between the garage and conditioned space that are required to have fire protection are not required to meet the U-factor requirement.

3.3.1.3 Skylights and Tubular Daylight Devices

Skylights and tubular daylight devices (TDD) are an exceptional source of daylight and passive solar heating, illuminating rooms with direct and indirect sunlight. When used appropriately, daylighting can increase the quality of light in a room and reduce dependence upon electrical lighting.

Skylights and TDDs don't typically have the same thermal properties as vertical fenestration and can be prone to greater heat loss in winter and solar heat gain during the summer. When a building designer optimizes the whole envelope glazing arrangement for daylight and thermal control, significant heating and cooling energy savings can be realized, especially when skylights and TDDs are as efficient as other vertical windows used.

Windows are considered part of an exterior wall when the slope is 60° or more as measured from the horizontal. Where the slope of fenestration is less than 60°, the glazing indicated as a window is considered a skylight and part of the roof.

3.3.1.4 Fenestration Subcategories

- A. **Manufactured fenestration** is a fenestration product constructed of materials that are factory-cut or otherwise factory-formed with the specific intention of being used to fabricate a fenestration product. Knocked down or partially assembled products may be sold as a fenestration product when provided with temporary and permanent labels, as described in §10-111, or as a site-built fenestration product when not provided with temporary and permanent labels, as described in §10-111.
- B. **Site-built fenestration** is designed to be field-glazed or field-assembled units, using specific factory-cut or other factory-formed framing, and glazing units that are manufactured with the intention of being assembled at the construction site. These include storefront systems, curtain walls or large-track sliding glass walls, and atrium roof systems.
- C. **Field-fabricated fenestration** is when the windows are fabricated at the building site from elements that are not sold together as a fenestration product (that is, separate glazing, framing, and weatherstripping elements). Field-fabricated does not include site-assembled frame components that were manufactured elsewhere with the intention of being assembled on site (such as knocked-down products, sunspace kits, and curtain walls).

3.3.1.5 Fenestration Definitions

- A. **Center of glass.** U-factor, SHGC, and VT are measured only through glass at least 2.5 inches from the edge of the glass or dividers.
- B. **Clear glass** has little, if any, observable tint with an IG unit with an SHGC of 0.5 or greater.
- C. **Chromogenic** is a class of glazing that can change the optical properties by including active materials (e.g. electrochromic) and passive materials (e.g.

photochromic and thermochromic) permanently integrated into the glazing assembly.

Electrochromatic is a class of glazing that tints on demand using a small amount of electricity.

- D. **Divider (muntin).** An element that physically or visually divides different lites of glass. It may be a true divided lite, between the panes, and/or applied to the exterior or interior of the glazing.
- E. **Double-pane window.** Double-pane (or dual-pane) glazing is made of two panes of glass (or other glazing material) separated by space (generally 1/4" [6 mm] to 3/4" [18 mm]) filled with air or other gas. Two panes of glazing laminated together do not constitute double-pane glazing.
- F. **Dynamic glazing.** Glazing systems that have the ability to reversibly change the performance properties, including U-factor, solar heat gain coefficient (SHGC), and/or visible transmittance (VT) between well-defined end points. Includes active materials (for example, electrochromic) and passive materials (for example, photochromic and thermochromic) permanently integrated into the glazing assembly.
With appropriate controls, electrochromic glass can be darkened or lightened to adjust the levels of daylight and solar heat gain. These products have the ability to reversibly change the SHGC and VT between well-defined endpoints.
Integrated shading systems is a class of fenestration products including an active layer (for example, shades, louvers, blinds, or other materials) permanently integrated between two or more glazing layers and that has the ability to reversibly change performance properties, including U-factor, SHGC, and/or VT between well-defined end points.
- G. **Fixed.** The fenestration product cannot be opened.
- H. **Gap width.** The distance between glazing in multiglazed systems (e.g., double or triple glazing). This dimension is measured from inside surface to inside surface. Some manufacturers may report "overall" IG unit thickness, which is measured from outside surface to outside surface.
- I. **Grille.** See Divider.
- J. **Insulating glass unit (IG unit or IG).** An IG unit includes the glazing, coatings, tinting, spacer(s), films (if any), gas infills, and edge caulking.
- K. **Light or lite.** A layer of glazing material, especially in a multilayered IG unit. Referred to as panes in §110.6 when the lites are separated by a spacer from inside to outside of the fenestration.
- L. **Low-e coatings.** Low-emissivity coatings are special coatings applied to the second, third, or fourth surfaces in double-glazed windows or skylights. As the name implies, the surface has a low emittance, meaning that radiation from that surface to the surface it "looks at" is reduced. Since radiation transfer from the hot side to the cool side of the window is a major component of heat transfer in

glazing, low-e coatings are very effective in reducing the U-factor. They do nothing, however, to reduce losses through the frame. Low-e coatings can be engineered to have different levels of solar heat gain. Generally, there are two kinds of low-e coatings:

1. Low-solar-gain low-e coatings are formulated to reduce air-conditioning loads. Fenestration products with low-solar-gain low-e coatings typically have an SHGC of 0.40 or less. Low-solar-gain low-e coatings are sometimes called *spectrally selective coatings* because they filter much of the infrared and ultraviolet portions of the sun's radiation while allowing visible light to pass through.
2. High-solar-gain low-e coatings, by contrast, are formulated to maximize solar gains. Such coatings would be preferable in passive solar applications or where there is little air conditioning.

Another advantage of low-e coatings, especially low-solar-gain low-e coatings, is that when they filter the sun's energy, they generally remove between 80 percent and 85 percent of the ultraviolet light that would otherwise pass through the window and damage fabrics and other interior furnishings. This is a major advantage for homeowners and can be a selling point for builders.

- M. **Mullion.** A frame member that is used to join two windows into one fenestration unit.
- N. **Muntin.** See Dividers.
- O. **Nonmetal frame.** Includes vinyl, wood, fiberglass, and other low-conductance materials. Vinyl is a polyvinyl chloride (PVC) compound used for frame and divider elements with a significantly lower conductivity than metal and a similar conductivity to wood. Fiberglass has similar thermal characteristics. Nonmetal frames may have metal strengthening bars entirely inside the frame extrusions or metal-cladding only on the surface.
- P. **Operable.** The fenestration product can be opened for ventilation.
- Q. **Solar heat gain coefficient (SHGC).** A measure of the relative amount of heat gain from sunlight that passes through a fenestration product. SHGC is a number between zero and one that represents the ratio of solar heat that passes through the fenestration product to the total solar heat that is incident on the outside of the window. A low SHGC number (closer to 0) means that the fenestration product keeps out most solar heat. A higher SHGC number (closer to 1) means that the fenestration product lets in most of the solar heat. SHGC or SHGC_t is the SHGC for the total fenestration product and is the value used for compliance with the standards.
- R. **Spacer or gap space.** A material that separates multiple panes of glass in an insulating glass unit.

- S. **Thermal break frame.** Includes metal frames that are not solid metal from the inside to the outside but are separated in the middle by a material with a significantly lower conductivity.
- T. **Tinted.** Glazing products formulated to have the appearance of color that alters the solar heat gain and visible transmittance. Common colors include gray, bronze, green, and blue. Some coatings can also appear tinted.
- U. **U-factor.** A measure of how much heat can pass through a construction assembly or a fenestration product. The lower the U-factor, the more energy efficient the product is. The units for U-factor are British thermal units (Btu) of heat loss each hour per square foot (ft²) of window area per degree Fahrenheit (°F) of temperature difference (Btu/hr-ft²-°F). U-factor is the inverse of R-value. The U-factor considers the entire product, including losses through the center of glass, at the edge of glass where a metal spacer typically separates the double-glazing panes, losses through the frame, and through the mullions. For metal-framed fenestration products, the frame losses can be significant.
- V. **Visible transmittance (VT)** is the ratio of visible light transmitted through the fenestration. The higher the VT rating, the more light is allowed through a window.
- W. **Window films** are composed of a polyester substrate to which a special scratch-resistant coating is applied on one side, with a mounting adhesive layer and protective release liner applied to the other side.

3.3.2. Mandatory Requirements §10-111, §10-112, §110.6

3.3.2.1 Fenestration Products and Labeling §10-111; §110.6(a)5

The National Fenestration Rating Council (NFRC) is the entity recognized by the California Energy Commission to supervise the rating and labeling of fenestration products. NFRC maintains the Certified Product Directory, containing NFRC certified U-factors, SHGC and VT values for thousands of fenestration products, on its website at <http://www.nfrc.org>.

Fenestration product performance data used in compliance calculations must be provided through the NFRC rating program and must be labeled by the manufacturer with the rated U-factor, SHGC, and VT in accordance with §10-111 procedures.

Estimating the rate of heat transfer through a fenestration product is complicated by the variety of frame configurations for operable windows, the different combinations of materials used for sashes and frames, and the difference in sizes available in various applications. The NFRC rating system makes the differences uniform, so that an entire fenestration product line is assumed to have only one typical size. The NFRC-rated U-factor may be obtained from the directory of certified fenestration products, directly from a manufacturer's listing in product literature, or from the product label.

U-factor and solar heat gain (SHGC) are factors that affect the energy performance of a window. There is no minimum requirement for visual transmittance (VT) for low-rise residential buildings but is used for informational purposes. Product labels that clearly state these energy performance ratings help consumers compare the energy efficiency of window and glazed door products of different brands and manufacturers.

There are two types of labels that may be used to meet the requirements in the Energy Standards: an NFRC-certified product label or a default label. Manufactured products will need to have both an NFRC temporary label listing certified performance values and a permanent label with information that can be used to trace the product certification file and show that the manufacturer has certified the product per one of the testing methods described in Table 3-2. See the “Certified Product Labels” section for more information. Default U-factors and SHGC are used when the manufacturer has not certified the product through the NFRC and for site-built fenestration. The temporary default label shall meet the requirements per §10-111. See the “Default Label” section for more information.

3.3.2.2 Certified Product Labels: Temporary and Permanent

1. Temporary Label for NFRC Certified Manufactured Fenestration Products

The Energy Standards require that manufactured fenestration have both temporary and permanent labels. The temporary label shows the U-factor and SHGC for each rated window unit. The label must also show that the product meets the air infiltration criteria of §110.6(a)1. The temporary label must not be removed before inspection by the enforcement agency.

Figure 3-2: Sample Temporary NFRC Label

	World's Best Window Co. Millennium 2000+ Vinyl-Clad Wood Frame Double Glazing • Argon Fill • Low E Product Type: Vertical Slider	
	ENERGY PERFORMANCE RATINGS	
U-Factor (U.S./I-P)	Solar Heat Gain Coefficient	
0.30	0.30	
ADDITIONAL PERFORMANCE RATINGS		
Visible Transmittance	Air Leakage (U.S./I-P)	
0.51	0.2	
<small>Manufacturer stipulates that these ratings conform to applicable NFRC procedures for determining whole product performance. NFRC ratings are determined for a fixed set of environmental conditions and a specific product size. NFRC does not recommend any product and does not warrant the suitability of any product for any specific use. Consult manufacturer's literature for other product performance information. www.nfrc.org</small>		

Source: National Fenestration Rating Council

2. National Fenestration Rating Council (NFRC) Permanent Label

The permanent label must, at a minimum, identify the certifying organization and have an ID number or code to allow tracking back to the original information on file with the certifying organization, NFRC. The permanent label can also be inscribed on the spacer, etched on the glass, engraved on the frame, or otherwise located so as not to affect aesthetics.

3.3.2.3 Default Label: Temporary

The manufacturer can choose to use Energy Standards default values from Table 110.6-A for U-factors and Table 110.6-B for SHGC. The product shall meet the air infiltration requirements of §110.6(a)1, U-factor criteria of §110.6(a)2, and SHGC criteria of §110.6(a)3 in the Energy Standards. The manufacturer must attach a temporary label meeting the following specific requirements. (Permanent etching labels are not required.)

There is no template for the default temporary label. It must be clearly visible and large enough for the enforcement agency field inspectors to read easily. It must include all information required by the Energy Standards. The minimum suggested label size is 4 in. x 4 in., and the label must have the following words at the bottom of the label as noted in Figure 3-3:

“Product meets the air infiltration requirements of §110.6(a)1, U-factor criteria of §110.6(a)2, SHGC criteria of §110.6(a)3 and VT criteria of §110.6(a)4 of the 2019 California Building Energy Efficiency Standards for Residential and Nonresidential Buildings.”

The manufacturer ensures the U-factor and SHGC default values are large enough to be readable from four feet away. The manufacturer ensures the appropriate boxes are checked and indicated on the default label.

Figure 3-3: Sample of Default Temporary Label

2019 California Energy Commission Default Label XYZ Manufacturing Co.		
Key Features:	<input type="checkbox"/> Doors	<input type="checkbox"/> Double-Pane
	<input type="checkbox"/> Skylight	<input type="checkbox"/> Glass Block
Frame Type	Product Type:	Product Glazing Type:
<input type="checkbox"/> Metal	<input type="checkbox"/> Operable	<input type="checkbox"/> Clear
<input type="checkbox"/> Non-Metal	<input type="checkbox"/> Fixed	<input type="checkbox"/> Tinted
<input type="checkbox"/> Metal, Thermal Break	<input type="checkbox"/> Greenhouse/Garden Window	<input type="checkbox"/> Single-Pane
<input type="checkbox"/> Air space 7/16 in. or greater <input type="checkbox"/> With built-in curb <input type="checkbox"/> Meets Thermal-Break Default Criteria	-----	To calculate VT see NA6
California Energy Commission Default U-factor =	California Energy Commission Default SHGC =	California Energy Commission Calculated VT =
Product meets the air infiltration requirements of §110.6(a)1, U-factor criteria of §110.6(a)2, SHGC criteria of §110.6(a)3 and VT criteria of §110.6(a)4 of the 2019 Building Energy Efficiency Standards for Residential and Nonresidential Buildings.		

Source: California Energy Commission



At the field inspection, the field inspector verifies that the fenestration U-factor and SHGC values meet the energy compliance values by checking the label sticker on the product.

If no labels are available on site for verification, the field inspector should not allow any further installation of fenestration until proof of efficiency (label) is produced. In cases when proof is not met, the field inspector should not allow construction until the designer or builder can produce such labels.

Manufactured Products. Product must be rated by the National Fenestration Rating Council (NFRC) and be listed in NFRC’s Certified Product Directory (CPD). The test procedure for U-factor is NFRC 100, and for SHGC and VT is NFRC 200 and NFRC 202, or ASTM E972 for translucent panels, and NFRC 203 for tubular daylighting devices (TDDs) and for certain types of other skylights.

Energy Commission Default Tables 110.6-A and 110.6-B in the Energy Standards list the worst-case values that must be assumed in most cases when fenestration is not rated by NFRC. For example, a single-pane, operable, metal-framed fenestration product has a default U-factor of 1.28. To get credit for high-performance window features such as low-emissivity (low-e) coatings and thermal break frames, the window manufacturer must have the window tested, labeled, and certified according to NFRC procedures. When the Energy Standards default values are used, they must be documented on a temporary default label (Figure 3-3).

Site-Built Products. For special cases in low-rise residential construction in which site-built products are installed, the site-built products shall be treated the same as manufactured products. U-factor and SHGC values must come from NFRC ratings or from the default Table 110.6-A and Table 110.6-B of the Energy Standards. Alternatively, calculation procedures in Reference Appendix NA6 for nonrated site-built fenestration may be used if the area of the site-built fenestration in a dwelling is less than 250 ft² or 5 percent of the conditioned floor area, whichever is larger.

Field-Fabricated Products. Field-fabricated fenestration must always use the Energy Commission default U-factors from Table 110.6-A and SHGC values from Table 110.6-B of the Energy Standards.

Example 3-1: Labels When Using CEC Default Values

Question: When windows are labeled with a default value, are there any special requirements that apply to the label?

Answer: All windows must meet the mandatory requirements in §110.6 and §110.7, unless exempted. These criteria apply to fenestration products labeled with default values:

The administrative regulations (§10-111) require that the words “CEC Default U-factor” and “CEC Default SHGC” appear on the temporary label before the U-factor or SHGC (not in a footnote).

The U-factor and SHGC for the specific product must be listed. If multiple values are listed on the label, the manufacturer must identify the appropriate value for the labeled product. Marking the correct value must be done in one of the following ways:

1. Circle the correct U-factor and SHGC (permanent ink).
2. Black out all values except the correct U-factor and SHGC (permanent ink).
3. Make a hole punch next to the appropriate values.

3.3.3. U-Factor and SHGC Ratings §110.6(a), Table 110.6-A, Table 110.6-B

Determining U-Factor and SHGC. The Energy Standards require that U-factor and solar heat gain coefficient (SHGC) be calculated using standardized procedures to ensure that the thermal performance or efficiency data for fenestration products is accurate. The data provided by different manufacturers within each fenestration type (windows, doors,

skylights, TDDs) can easily be compared to others within that type and can be verified independently.

Acceptable methods of determining U-factor and SHGC are shown in Table 3-2.

Table 3-2: Methods for Determining U-Factor and SHGC

U-Factor/SHGC Determination Method	Manufactured Windows and Doors	Manufactured Skylights	Site-Built Fenestration (Vertical & Skylight)	Field-Fabricated Fenestration	Glass Block
NFRC-100 (U-Factor) NFRC-200 (SHGC)	✓	✓	✓	N/A	N/A
Standards Default Table 110.6-A (U-Factor) Table 110.6-B (SHGC)	✓	✓	✓	✓	✓
NFRC's Component Modeling Approach (CMA) ¹	N/A	N/A	N/A	N/A	N/A
NA6 ²	N/A	N/A	✓	N/A	N/A

1. The NFRC CMA method is limited to nonresidential and is not currently approved for residential use.
 2. The Alternative Default U-factors and SHGCs from Reference Appendix NA6 may be used only for total site-built vertical fenestration plus skylights up to 250 ft² or 5% of the conditioned floor area, whichever is larger. Residential area allowances are defined in NA6.1(b).



When the alternative procedure from NA6 for unrated site-built fenestration is used in a residential application, it may not meet the prescriptive values as required by Table 150.1-A, even if area-weighted averaging is implemented. In this case, it would be necessary to use the performance approach to meet energy compliance.

Example 3-2: Multiple Window Types in a Project

Question: My new home will have a combination of window types, including fixed, operable, wood, metal, and so forth, some of which are field-fabricated. What are the options for showing compliance with the standards?

Answer: All windows must meet the mandatory requirements of §110.6 and §110.7 and the mandatory maximum area-weighted average U-factor of 0.58 from §150.0(q), unless exempted. For field-fabricated windows, you must select U-factors and SHGC values from the default tables (Table 110.6-A and Table 110.6-B of the Energy Standards). Windows that are not field-fabricated must be labeled with NFRC-certified or default efficiencies. Few fenestration products in the default tables meet the mandatory maximum U-factor of 0.58 on their own.

If the area-weighted average U-factors or SHGC values do not comply with the prescriptive requirements, the performance method must be used. To simplify data entry into the compliance software, you may choose the U-factor from Table 110.6-A of the Energy Standards that is the highest of any of the windows planned to be installed and use this for all windows for compliance. However, you must use the appropriate SHGC from Table 110.6-B for each window type being installed.

Example 3-3: Glass Block

Question 1: Which U-factor is used for an operable metal-framed glass block?

Answer 1: For glass block, use the U-factor from Table 110.6-A of the Energy Standards for the frame type in which the glass blocks are installed and for the fenestration product type. The U-factor for operable metal-framed glass block from Table 110.6-A is 0.87.

Question 2: Which SHGC is used for clear glass block, and can it be used for tinted glass block?

Answer 2: Use the default SHGC values from Table 110.6-B, depending upon whether the glass block has a metal or nonmetal frame and whether it is operable or fixed. The default SHGC table does not include tinted glass block, so use the clear glass block SHGC as the default for both clear and tinted glass block.

Question 3: Does it need a label?

Answer 3: Glass block is considered a field-fabricated product and may be installed only if compliance is demonstrated on the compliance documents.

Example 3-4: Sunrooms

Question: Is there a default U-factor for the glass in sunrooms?

Answer: If the sunroom is part of the conditioned floor area, then yes. For the horizontal or sloped portions of the sunroom glazing, use the U-factor for skylights. For the vertical portions, use the U-factors for fixed windows, operable windows, or doors, as appropriate. As a simple alternative, the manufacturer may label the entire sunroom with the highest U-factor of any of the fenestration types within the assembly.

Example 3-5: Glazed Doors

Question 1: How are exterior glazed doors treated in compliance documentation for U-factor and SHGC?

Answer 1: All doors with glass area greater than or equal to 25 percent of the door area, which includes French doors, are defined as fenestration products and are covered by the NFRC Rating and Certification Program. The U-factor and SHGC for doors with 25 percent or more glass area may be determined in one of two ways:

1. Use the NFRC rated and labeled values.
2. Refer to Table 110.6-A and 110.6-B of the Energy Standards. The values are based upon glazing and framing type.

In special cases where site-built fenestration is being installed in a residential application, the site-built windows and glazed doors can use an alternative method to calculate the U-factor and the SHGC by using the manufacturer's center-of-glass values (COG). The COG values are calculated in accordance with Reference Appendix NA6. To use this calculation, the maximum allowed site-built fenestration is 250 ft² or 5% of the conditioned floor area, whichever is larger.

Question 2: How can I determine a U-factor and SHGC for doors when less than 25 percent of the door area is glass?

Answer 2: Doors with less than 25 percent glass area are treated as opaque exterior doors. For prescriptive or performance approaches, only the U-factor is used for this product type. Use one of the following options for U-factor of the door:

1. The NFRC label if one is available
2. The default values from Table JA4.5.1 of the Reference Appendices

Example 3-6: Tubular Daylighting Device With Single-Pane Diffuser

Question: A tubular daylighting device will be used to get daylight into a house. The skylight has a clear plastic dome exterior to the roof, a single-pane ¼-inch (6 mm)-thick acrylic diffuser mounted at the ceiling, and a metal tube connecting the two. How are U-factor and SHGC determined for the performance approach to comply with the Energy Standards, if U_c is 1.20 and $SHGC_c$ is 0.85?

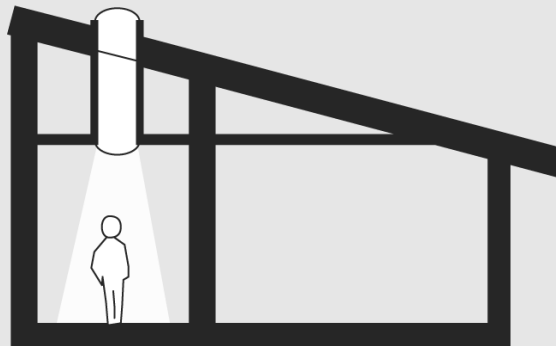

Answer: There are three methods available for determining the U-factor for tubular daylighting devices (TDD):

1. Use the NFRC label if the product has been tested and certified under NFRC procedures. This requires a label that states: "Manufacturer stipulates that this rating was determined in accordance with applicable NFRC procedures NFRC 100," followed by the U-factor.

2. Use the default U-factor from Table 110.6-A of the Energy Standards. This tubular product would be considered a metal frame, fixed, single-pane skylight resulting in a U-factor of 1.19, which must appear on a label preceded by the words “CEC Default U-factor.” (A tubular daylighting device would have to have two panes of glazing with an air space of less than 2 inches [50 mm] between them at the plane of the ceiling insulation for it to be considered double-pane.)

3. Determine the U-factor from Reference Appendix NA6, Equation NA6-1. The U-factor for this tubular daylighting device would be based on metal with no curb (Table NA6-5). The U-factor for this skylight, using Equation NA6-1, is 1.25, where $U_t = (0.195 + (0.882 \times 1.20))$. This must appear on a label stated as “CEC Default U-factor 1.25.”

There also are three methods available for determining SHGC for tubular daylighting devices (TDD):

1. Use the NFRC label if the skylight has been tested and certified under NFRC procedures and requires a label that states: “Manufacturer stipulates that this rating was determined in accordance with applicable NFRC procedures.”

2. Use the default table SHGC in Table 110.6-B of the Energy Standards. This tubular daylight device would be considered a metal-frame, fixed, clear, single-pane skylight resulting in an SHGC of 0.83, which must appear on a label stated as “CEC Default SHGC 0.83.”

3. Determine the SHGC from Reference Appendix NA6, Equation NA6-2. The SHGC for this skylight using Equation NA6-2 is 0.81, where $SHGC_t = (0.08 + (0.86 \times 0.85))$. This must appear on a label stated as “CEC Default SHGC 0.81.”

Example 3-7: Tubular Daylighting Device With Dual-Pane Diffuser

Question: How are the U-factor and the SHGC determined if the tubular daylighting device in the previous example has a dual-pane diffuser (instead of single-pane) mounted at the ceiling?

Answer: The procedure would be exactly the same as Example 3-6, except that the double-pane U-factor and SHGC values from Tables 110.6-A and 110.6-B of the Energy Standards would be used instead of single-pane values. Up to 3 ft² of tubular daylighting device with a dual-pane diffuser is assumed to have the prescriptive U-factor and SHGC from Table 150.1-A or Table 150.1-B for compliance calculations (Exception 1 to §150.1[c]3A).

3.3.4. Air Leakage §110.6(a)1, §110.7

Air leakage (AL) is a measurement of heat loss and gain by infiltration through cracks in the window assembly, which can affect occupant comfort. The lower the

AL, the lower the amount of air that will pass through cracks in the window assembly.

- A. **Manufactured Products.** Must be tested and certified to leak no more than 0.3 cubic feet per minute (cfm) per ft² of the window area. This mandatory measure applies to all manufactured windows that are installed in newly constructed residential (including high-rise) buildings or newly installed in existing buildings. To determine leakage, the standard test procedure requires manufacturers to use either NFRC 400 or ASTM E283 at a pressure differential of 75 Pascal (or 1.57 pounds/ft²).
- B. **Site-Built Products.** There are no specific air leakage requirements for site-built fenestration products, but the Energy Standards require limiting air leakage by weatherstripping and caulking.
- C. **Field-Fabricated Products.** No air leakage testing is required for field-fabricated fenestration products; however, the Energy Standards still require limiting air leakage by weatherstripping and caulking.
- D. **Exterior Doors.** Exterior doors, which includes pet doors, must meet the following requirements:
 - 1. Manufactured exterior doors must be certified as meeting an air leakage rate of 0.3 cfm/ft² of door area at a pressure differential of 75 Pascal, which is the same as windows.
 - 2. Field-fabricated exterior doors must comply with the requirements of §110.6, as described by “Other Openings.” For example, these must be caulked and weatherstripped.
 - 3. Any door with a surface area greater than or equal to 25 percent glass is considered a glazed door and must comply with the mandatory and applicable prescriptive and performance requirements of §150.0, §150.1, and §150.2.
 - 4. For any door with a surface area less than 25 percent glass, the area may be exempt in accordance with one of the exceptions of §150.0, §150.1, and §150.2.

Example 3-8: Which Fenestration Products Must Be Tested and Certified for Air Leakage?

Question: As a manufacturer of fenestration products, I place a temporary label with the air infiltration rates on my products. Can you clarify which products must be tested and certified?

Answer: Each product line must be tested and certified for air infiltration rates. Features such as weather seal, frame design, operator type, and direction of operation affect air leakage. Every product must have a temporary label certifying that the air infiltration requirements are met. This temporary label may be combined with the temporary U-factor, SHGC, and VT label.

Example 3-9: Infiltration Requirements for Custom Windows

Question: Is a custom window “field-fabricated” for meeting air infiltration requirements?

Answer: No. Most custom windows are manufactured and delivered to the site either completely assembled or “knocked down,” which means they are a manufactured product. A window is considered field-fabricated when the windows are assembled at the building site from the various elements that are not sold together as a fenestration product (such as glazing, framing, and weatherstripping). Field-fabricated does not include site-assembled frame components that were manufactured elsewhere with the intention of being assembled on site (such as knocked-down products, sunspace kits, and curtain walls).

Example 3-10: Pet Doors to the Exterior

Question: How is a pet door installed in an exterior wall accounted for in a newly constructed residential building design?

Answer: Pet doors must meet all exterior door requirements. U-factor must be determined by an NFRC accredited testing lab using NFRC 100 U-factor requirements; otherwise, nonrated pet doors will assume no more than the maximum U-factor of 0.99 based on a nonmetal single-pane door U-factor. (See Table 110.6-A of the Energy Standards.) The rated pet door shall not exceed 0.3 cfm/ft² air leakage when tested using ASTM E283. The performance compliance approach must be used when a pet door is installed.

3.3.5. Prescriptive Requirements §150.1(c)3, §150.1(c)4, §150.1(c)5, Table 150.1-A and Table 150.1-B**Fenestration**

Prescriptive requirements described in this chapter typically refer to Table 150.1-A or 150.1-B. The maximum fenestration U-factor required prescriptively for all climate zones is 0.30, and the maximum SHGC is 0.23 for residences in Climate Zones 2, 4, and 6 through 15. Homes constructed in Climate Zones 1, 3, 5, and 16 have no SHGC requirements.

The requirements apply to fenestration products without consideration of insect screens or interior shading devices. With some exceptions, some fenestration products may exceed the prescriptive requirement as long as the U-factor and SHGC of windows, glazed doors, and skylights can be area weight-averaged together to meet the prescriptive requirement using the CF1R-ENV-02-E compliance document in Appendix A of this manual.

Opaque Doors

An *opaque door* is an installed swinging door separating conditioned space from outside or adjacent unconditioned space with less than 25 percent glazed area. A door that has 25 percent or more glazed area is considered a glazed door and is treated like a fenestration product (Section 3.5.8).

Opaque doors are prescriptively required to have an area-weighted average U-factor no greater than U-0.20, per Table 150.1-A and Table 150.1-B. Swinging doors between the garage and conditioned space that are required to have fire protection are exempt from the prescriptive requirement. The U-factor must be rated in accordance with NFRC 100, or the applicable default U-factor defined in Reference Appendix Table 4.5.1 must be used.



At the field inspection, the field inspector verifies that the door U-factor meets the energy compliance values by checking the NFRC label sticker on the product. When manufacturers do not rate the thermal efficiencies by NFRC procedures, the Energy Commission default values must be used and documented on a temporary default label (Figure 3-3).

Table 3-3: Maximum U-Factors, SHGC, and Fenestration Area by Climate Zone in the Prescriptive Package

Climate Zone	1, 3, 5, 16	2,4,6-15
Maximum Fenestration U-Factor	0.30	0.30
Maximum Fenestration SHGC	NR	0.23
Maximum Fenestration Area	20%	20%
Maximum West-Facing Fenestration Area	NR	5%
Maximum Opaque Door U-Factor	0.20	0.20

Figure 3-4: Prescriptive Package, SHGC, and West-Facing Area Criteria by Climate Zone

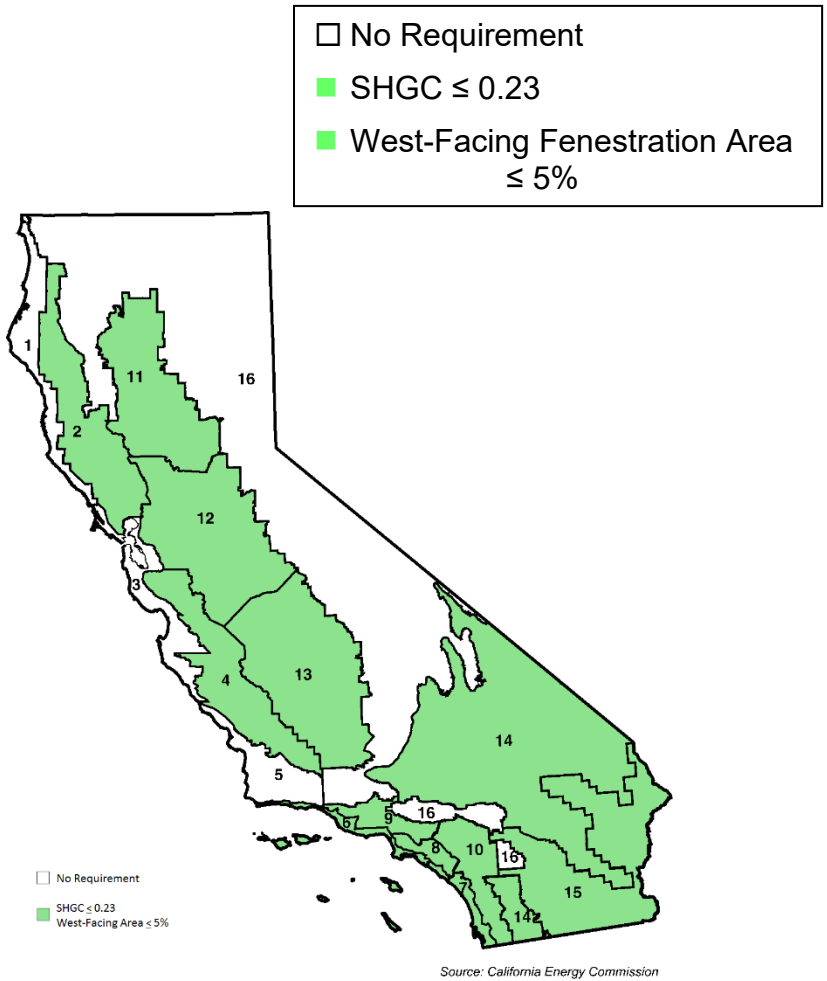

3.3.5.1 Fenestration and Opaque Door Prescriptive and Mandatory Exceptions

A. Glazed Doors

Any door that is more than 25 percent or greater glass is considered a glazed door and must comply with the mandatory measures and other requirements applicable to a fenestration product. Up to 3 ft² of glass in a door is exempt from the U-factor and SHGC requirements (or can be considered equivalent to the prescriptive package values). The U-factor and SHGC shall be based on either the NFRC values for the entire door, including glass area, or use default values in Table 110.6-A for the U-factor and Table 110.6-B for the SGHC. If the door has less than 25 percent glazing, the opaque part of the door is ignored in the prescriptive approach.

B. Tubular Daylighting Device (TDD)

In each dwelling unit, up to 3 ft² of tubular daylighting devices area with dual-pane diffusers at the ceiling are exempt from the prescriptive U-factor and SHGC requirements, where the TDD area is included in the maximum of 20

percent fenestration area. However, the U-factor shall not exceed a maximum of 0.58. See §150.0(q) and Exception 1 of §150.1(c)3A.

C. Opaque Doors

Opaque doors between the garage and conditioned space that are required to have fire protection are not required to meet the prescriptive U-factor requirement of 0.20. See Exception to §150.1(c)5.

D. Skylights

Each new dwelling unit may have up to 16 ft² of skylight area. The total area of skylights is included in the maximum of 20 percent fenestration area and must meet a maximum 0.55 U-factor and a maximum SHGC of 0.30. See Exception 2 of §150.1(c)3A.

Aside from the specific exceptions to the fenestration prescriptive requirements, the area weight-averaged U-factor and SHGC must not exceed the 0.55 U-factor and cannot be greater than the 0.30 SHGC when large numbers of skylights are used for prescriptive compliance. Alternatively, the performance approach may be used to meet energy compliance.

E. Dynamic Glazing

If a dwelling unit includes a type of dynamic glazing that is electrochromatic, chromogenic, or an integrated shading device and the glazing is automatically controlled, use the lowest U-factor and lowest SHGC to determine compliance with prescriptive package fenestration requirements. Since this type of product has compliance ratings that vary, it cannot be weight averaged with nonchromogenic products as per Exception 3 of §150.1(c)3A.

F. Site-Built Fenestration

When a dwelling unit contains a combination of manufactured and site-built fenestration, only the site-built fenestration values can be determined by using Reference Appendix NA6. All fenestration, including site-built, can default to Table 110.6-A and Table 110.6-B.

G. Maximum Area

The prescriptive requirements limit total glass area to a maximum of 20 percent of the conditioned floor area in all climate zones.

Note: There are exceptions to the prescriptive requirements for alterations in §150.2(b)1A that allow additional glass area beyond the 20 percent limitation, including west-facing glass. See Chapter 9 for more information on alterations.

H. Greenhouse Windows/Garden Windows

Compared to other fenestration products, the NFRC-rated U-factor for greenhouse windows are comparatively high. Section 150.0(q) includes an exception from the U-factor requirement for dual-glazed greenhouse or garden windows that total up to 30 ft² of fenestration area.

3.3.5.2 Prescriptive Credit for Exterior Shading Devices §150.1(c)4

The prescriptive requirements require fenestration products with a SHGC of 0.23 or lower in Climate Zones 2, 4, and 6 through 15. However, a fenestration product with an SHGC greater than 0.23 may be used with the prescriptive requirements if a qualifying exterior shading device is used and the combined area-weighted average complies with the prescriptive requirements. Exterior shading devices and associated SHGC values are shown in Table 3-4. These include woven sunscreens as well as perforated metal sunscreens. As shown in the table, these devices transmit between 13 percent and 30 percent of the sun that strikes them.

Table 3-4: Exterior Shades and Solar Heat Gain Coefficients

Exterior Shading Device	SHGC*
Standard Bug (insect) Screen (default for windows)	0.76
Exterior Sunscreens With Weave 53 x 16/inch	0.30
Louvered Sunscreens w/Louvers as Wide as Window Openings	0.27
Low-Sun-Angle Louvered Sunscreen	0.13
Vertical Roller Shades or Retractable/Drop Arm/Combination/Marquisolette and Operable Awnings	0.13
Roll Down Blinds or Slats	0.13
None (for skylights only)	1.00
* Reference glass values assume single-pane clear glass and metal framing 1/8-inch double-strength (DSS) glass. Use CF1R-ENV-03 worksheet for calculation.	

When exterior overhangs are used, the SHGC requirements of the prescriptive package may be met if the calculated combination of the overhang and fenestration SHGC efficiency is equal or lower than 0.23.

For credit, exterior shading devices must be permanently attached as opposed to being attached using clips, hooks, latches, snaps, or ties. Exterior shading devices on windows or skylights that are prohibited by life-safety codes from being permanently attached for emergency egress reasons are exempt from this requirement.



Compliance document CF1R-ENV-03 is used to calculate the combined SHGC of windows and exterior shading devices. When exterior shades are required for compliance, they must be listed on the CF1R and be documented on the plans.

The SHGC of the window in combination with an exterior device is given by the following:

$$\text{Equation 3-1: } SHGC_{\text{combined}} = (0.2875 \times SHGC_{\text{max}} + 0.75) \times SHGC_{\text{min}}$$

All operable windows and skylights are assumed to have an insect screen as the default condition against which other window and exterior shading device combinations are compared. The standard case is a window with an SHGC of 0.23 and an insect screen with an SHGC of 0.76. For this default case, the SHGC of the window is the $SHGC_{\text{min}}$, and the SHGC of the exterior sunscreen is $SHGC_{\text{max}}$. Working through the math on the CF1R-ENV-03 form, $SHGC_{\text{combined}}$ is 0.23. This means that any combination of window SHGC and exterior SHGC that results in a $SHGC_{\text{combined}}$ of 0.23 or less complies with the prescriptive requirements.

Most of the shading devices (other than the default insect screen) have an SHGC of 0.30 or lower. Combining this with the SHGC of any window may result in a combined SHGC that is equal to or lower than the prescriptive criterion of 0.23. This method of combining the SHGC of the window with the SHGC of the exterior shading device can also be used in the whole-building performance approach.

3.3.6 Fenestration in the Performance Approach §150.1(b)

While the prescriptive requirements and mandatory measures establish a minimum level of building energy performance, opportunities to exceed the requirements of the Energy Standards are considerable. More information is included in the Performance Compliance section (Chapter 8).



Options that are recognized for credit through the performance method are called *compliance options*. Most require using the performance approach, but a few exterior shading devices and south-facing overhangs may be used to comply when using the prescriptive approach.

3.3.6.1 Fenestration Area and Orientation

The performance approach includes consideration of the fenestration area and orientation, which can have a big effect on energy use. Compliance is determined by comparing the proposed fenestration to the standard design fenestration.

For buildings with glazing areas less than or equal to 20 percent of the conditioned floor area (CFA), the standard design fenestration for new construction is modeled with the same glazing area as the proposed home with one-quarter of the window area on the north, east, south, and west orientations. For buildings with more than 20 percent of the CFA, the standard design is limited to 20 percent glass area.

Because of the effects of orientation and the fenestration product performance levels and other building features like overhangs, judging the particular area, orientation, and performance level is a compliance credit or penalty and can be difficult to determine without performance approach calculations.

3.3.6.2 Improved Fenestration Performance

The fenestration weighted average U-factor in the standard design for newly constructed buildings is 0.30 in all climate zones, as indicated in the single-family and multifamily prescriptive packages. Choosing high-performance fenestration that performs better than the prescriptive requirements level can earn significant credit through the performance method. For example, in air-conditioning climates, choosing a window with an SHGC lower than 0.23 will reduce the cooling loads compared to the standard design.

The magnitude of the effect will vary by climate zone. In mild coastal climates, the benefit from reducing fenestration U-factor will be smaller than in cold, mountain climates. Several factors affect window performance. For fenestration with NFRC ratings, the following performance features are accounted for in the U-factor and SHGC ratings:

1. Frame materials, design, and configuration (including cross-sectional characteristics). Fenestration can be framed in many materials. The most common include wood, aluminum, vinyl, fiberglass, or composites of these materials. Frames made of low-conductance materials like wood, vinyl, and fiberglass are better insulators than metal. Some aluminum-framed units have thermal breaks that reduce the conductive heat transfer through the framing element compared with similar units having no such conductive thermal break.
2. Number of panes of glazing, low-emissivity coatings, tints, fill gases, cavity dimensions, and spacer construction. Windows compliant with the prescriptive requirements are likely to have at least double-glazing with a low-emissivity coating and argon gas fill with an improved spacer. The choice of low-emissivity coating is particularly important as cooling climates will generally benefit from a low SHGC coating, while heating climates may benefit from a high SHGC coating. There are many ways to improve performance beyond the prescriptive levels. Adding glazing layers such as triple glazing and low-emissivity coatings such as those facing the conditioned space are two likely improvements.
3. Dynamic glazing with appropriate controls may also offer opportunities for improving performance.

3.3.6.3 Fixed Permanent Shading Devices

Shading of windows is also an important compliance option. Overhangs or sidefins that are attached to the building or shading from the building itself are compliance options for which credit is offered through the performance approach. However, no credit is offered for shading from trees, adjacent buildings, or terrain.

The ideal overhang is one that provides shade during the months when the building is likely to be in cooling mode and allows direct solar gains in the heating months. During the summer, the sun is high as it passes over the south side, while in the winter it is low, enabling solar radiation to pass beneath the overhang. Windows that face south can be effectively shaded by overhangs positioned above the window. Due to the potential effectiveness of south-facing overhangs, a prescriptive compliance option is offered. See Section 3.3.5.2 for details.

Shading is more challenging on the east and west sides of the house. When the sun strikes these façades, it is fairly low in the sky, making overhangs ineffective. Vertical fins can be effective, but they degrade the quality of the view from the window and limit the natural light that can enter. In cooling-dominated climates, the best approach is to minimize windows that face east and west. Landscaping features can be considered to increase comfort and energy performance of the building but cannot be used for compliance credit.

3.3.6.4 Interior Shading Devices

There is no credit for interior aftermarket shading devices, although they can be effective in reducing solar gains and should be considered by homeowners. These added interior shades are in the category of home furnishings and not a feature of the house that is provided by the builder or fenestration manufacturer. Draperies, interior blinds, interior shades, and other interior devices are not credited toward energy compliance. A default standard bug screen is still considered in performance calculations, so that estimates of energy use are more realistic and tradeoffs against other measures are more equitable.

Figure 3-5: Diagram of Integrated Shading System



3.3.6.5 Dynamic Glazing

Dynamic glazing products are either integrated shading systems or electrochromatic devices and are considered a fenestration product.

Source: NFRC Dynamic Glazing Products Fact Sheet

Integrated Shading Systems. These systems include blinds positioned between glass panes that can be opened and closed using automatic controls.

The labels for integrated shading systems will reflect the endpoints of the product performance for U-factor and SHGC (Figure 3-6). The unique rating “variable arrow”

identifier helps consumers understand the “dynamics” of the product and allows comparison with other similar dynamic fenestration products.

If the fenestration product can operate at intermediate states, a dual directional arrow (↔) with the word “Variable” will appear on the label. Some dynamic glazing is able to adjust to intermediate states, allowing for a performance level between the endpoints.

In Figure 3-6, the low value rating is displayed to the left (in the closed or darker position), and the high value rating is displayed to the right (in the open or lighter position). This lets the consumer know at a glance the best and worst case performance of the product and the default performance level. To use the high-performance values for integrated shading systems, the product must have an NFRC Certified Label sticker. Otherwise, the default values from Tables 110.6-A and 110.6-B must be used.

Chromatic Glazing. One type of dynamic glazing product uses a chromatic type of glass that has the ability to change the performance properties, allowing occupants to control their environment manually or automatically by tinting or darkening a glass with the flip of a switch. Some fenestration products can change performance automatically with the use of an automatic control or environmental signals. These high-performance windows can reduce energy costs due to controlled daylighting and unwanted heat gain or heat loss.

A view of chromatic glazing in the open (off) and closed (on) position is shown in Figure 3-7. Best-rated performance values may be used for compliance with an NFRC Certified Label sticker and when automatic controls are installed.

If the window includes either an NFRC label or automatic controls, but not both, then default to Table 150.1-A maximum U-factor of 0.30 and maximum SHGC of 0.23.

If neither an NFRC label nor automatic controls are included, then the default values from Tables 110.6-A and 110.6-B of the Energy Standards must be used.

3.3.6.6 Window Films §150.1(b)

Window films are polyester films that offer high clarity and can be pretreated to accept different types of coatings. There are three basic categories of window films:

Figure 3-6: Example of Integrated Shading System NFRC Label

	World's Best Window Co. Millennium 2000+ Vinyl-Clad Wood Frame Double Glazing • Dynamic Glazing • Argon Fill • Low E Product Type: Vertical Slider	
	ENERGY PERFORMANCE RATINGS	
U-Factor (U.S./I-P) 0.30 ↔ 0.40 <small>Off/Closed On/Open</small>	Solar Heat Gain Coefficient 0.10 ↔ 0.50 <small>Off/Closed On/Open</small>	
ADDITIONAL PERFORMANCE RATINGS		
Visible Transmittance 0.03 ↔ 0.65 <small>Off/Closed On/Open</small>	Air Leakage (U.S./I-P) 0.2	
<small>Manufacturer stipulates that these ratings conform to applicable NFRC procedures for determining whole product performance. NFRC ratings are determined for a fixed set of environmental conditions and a specific product size. NFRC does not recommend any product and does not warrant the suitability of any product for any specific use. Consult manufacturer's literature for other product performance information. www.nfrc.org</small>		

Source: NFRC Dynamic Glazing Products Fact Sheet

Figure 3-7: Chromatic Glazing

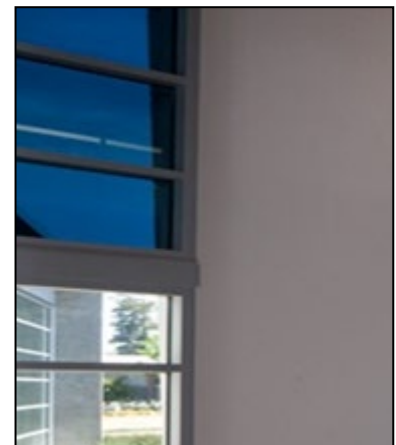

Source: Sage Electrochromics

Clear (nonreflective) films are used as security film to reduce ultraviolet (UV) light, which contributes greatly to fading. They are not commonly used for solar control or energy savings.

Tinted or dyed (nonreflective) films reduce both heat and light transmission, mostly through increased absorbance, and can be used in applications where the desired primary benefit is glare control, with energy savings being secondary.

Metalized (reflective) film can be metalized through vacuum coating, sputtering, or reactive deposition and may be clear or colored. Metalized films are preferred for energy savings applications because they reduce transmission primarily through reflectance and are manufactured to reflect heat more than visible light through various combinations of metals.

To receive window film compliance credit, the following must be met:

- The performance approach must be used to meet energy compliance.
- NFRC Window Film Energy Performance Label (Figure 3-8) is required for each different film applied. If there is no NFRC label, the default values from Tables 110.6-A and Table 110.6-B of the Energy Standards must be used.
- Window films must have at least a 15-year manufacturer warranty.

Figure 3-8 shows an example of a NFRC Attachment Ratings Label, which helps identify the energy performance of window films.

Figure 3-8: Window Film Energy Performance Label

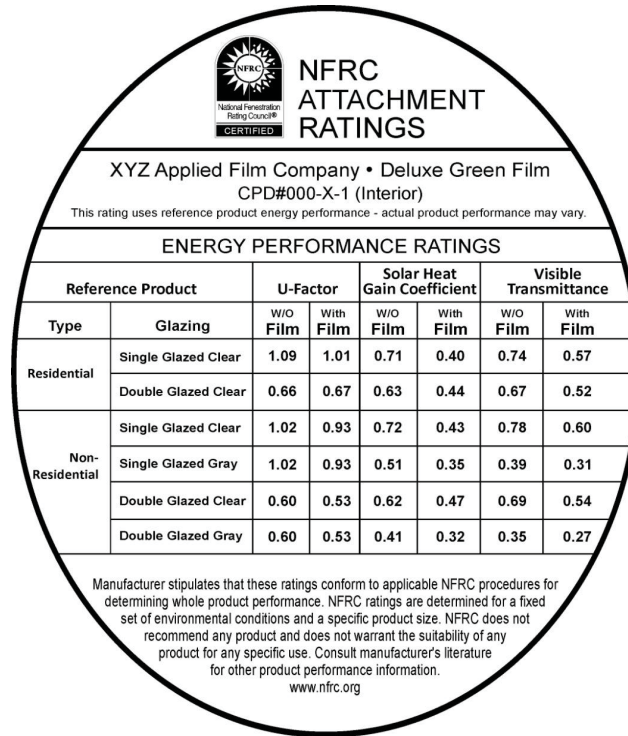

Source: NFRC Applied Film Products Fact Sheet

3.3.6.7 Bay Windows §150.1(b)

Bay windows are a special compliance case. Bay windows may have a unit NFRC rating (that is, the rating covers both the window and all opaque areas of the bay window), an NFRC rating for the window only, or no NFRC rating. Nonrated bay windows may or may not have factory-installed insulation.

A. NFRC Rated

For bay windows that come with an NFRC rating for the entire unit, compliance is determined based on the rough opening area of the entire unit, applying the NFRC U-factor and SHGC. If the unit U-factor and SHGC do not meet the package requirements or area-weighted average, the project must show compliance using the performance approach.

B. Nonrated



Bay windows with no rating for the entire unit (where there are multiple windows that make up the bay) and with factory-installed or field-installed insulation must comply accounting for the performance characteristics of each component separately.

- Opaque portions of bay windows including roofs and floors must be insulated to meet the wall insulation requirements for prescriptive compliance. The opaque portion must either meet the minimum insulation requirements of the prescriptive package for the applicable climate zone or be included in a weighted average U-factor calculation of an overall opaque assembly that does meet the prescriptive requirements.
- For the windows, the U-factor and SHGC values may be determined either from an NFRC rating or by using default values in Tables 110.6-A and 110.6-B of the Energy Standards. If the window U-factor and SHGC meet the package requirements, the bay window complies prescriptively (if overall building fenestration area meets prescriptive compliance requirements).
- If the bay window does not meet prescriptive requirements, the project must show compliance using the performance approach.

3.4 Opaque Envelope

This section of the building envelope chapter addresses the requirements for air leakage, roof products, radiant barriers, and vapor retarders in the building envelope. Fenestration, windows, glazed doors, and opaque doors are addressed in Section 3.3. Insulation is addressed in Section 3.5.

Table 3-5: Relevant Sections in the Energy Standards

Newly Constructed and Additions $\geq 1,000 \text{ ft}^2$	MANDATORY	PRESCRIPTIVE	PERFORMANCE
			
Air Leakage	§110.7	-	-
Roofing and Radiant Barriers	§10-113, §110.8(i) - §110.8(j)	§150.1(c)2, §150.1(c)11 Table 150.1-A	§150.1(a), §150.1(b)
Vapor Retarders	§150.0(g)	-	-

3.4.1 Opaque Envelope Definitions

Opaque elements of the building envelope significantly contribute to the related energy efficiency. Components of the building envelope include walls, floors, soffits, roofs, and ceilings. Envelope and other building components definitions are listed in §100.1(b) of the Energy Standards and the Reference Appendices JA1.

- A. **The exterior partition** is an opaque, translucent, or transparent solid barrier that separates conditioned space from ambient air or unconditioned space.
- B. **The demising partition** is a wall, fenestration, floor, or ceiling that separates conditioned space from enclosed unconditioned space.

- C. **The conditioned space** is an enclosed space within a building that is either directly conditioned or indirectly conditioned.
- D. **Unconditioned space** is enclosed space within a building that is neither directly conditioned nor indirectly conditioned.
- E. **Plenum** is an air compartment or chamber, including uninhabited crawl space, areas above a ceiling or below a floor, or attic spaces, to which one or more ducts are connected and that forms part of either the supply-air, return-air, or exhaust air system, other than the occupied space being conditioned.
- F. **Attic** is an enclosed space directly below the roof deck and above the ceiling.
- G. **Sloping surfaces** are considered either a wall or a roof, depending on the slope. (See Figure 3-9.) If the surface has a slope of less than 60° from horizontal, it is considered a roof; a slope of 60° or more is a wall. This definition extends to fenestration products, including windows in walls and any skylight types in roofs.

Figure 3-9: Slope of a Wall or Window (Roof or Skylight Slope Is Less Than 60°)

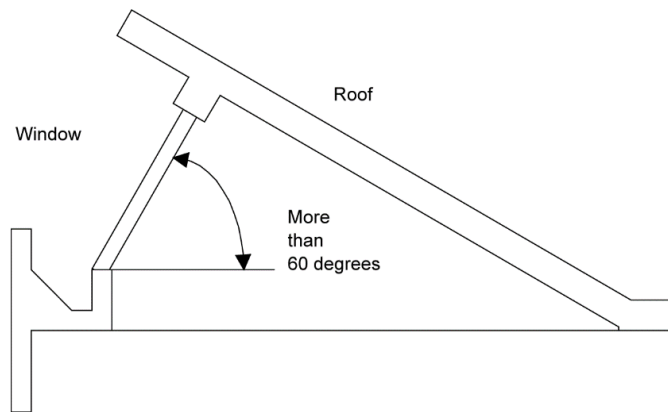

Source: California Energy Commission

- H. **The exterior roof** is an exterior partition that has a slope less than 60 degrees from horizontal, that has conditioned space below, and that is not an exterior door or skylight.
- I. **The roof deck** is the surface that supports the roofing material. Typically made of plywood or OSB, it is, in turn, supported by the roof framing members such as rafters or trusses.
- J. **Exterior floor/soffit** is a horizontal exterior partition, or a horizontal demising partition, under conditioned space.
- K. **Vapor retarder** or vapor barrier is a material or assembly designed to limit the amount of vapor moisture that passes through that material or assembly.
- L. **Roofing products** are the top layer of the roof that is exposed to the outside, which has properties including, but not limited to, solar reflectance, thermal emittance, and mass.

- M. **Cool roof** is a roofing material with high thermal emittance and high solar reflectance, or low thermal emittance and exceptionally high solar reflectance, as specified in Part 6, that reduces heat gain through the roof.
- N. **Solar reflectance** is the fraction of solar energy that is reflected by the roof surface.
- O. **Thermal emittance** is the fraction of thermal energy that is emitted from the roof surface.
- P. **A low-sloped roof** is a surface with a pitch less than 2:12 (less than 9.5 degrees from the horizon).
- Q. **A steep-sloped roof** is a surface with a pitch greater than or equal to 2:12 (9.5 degrees or greater from the horizontal).
- R. **Air leakage (AL)** is a measurement of heat loss and gain by infiltration through gaps and cracks in the envelope.

Infiltration is the *unintentional* replacement of conditioned air with unconditioned air through leaks or cracks in the building envelope. It is a major component of heating and cooling loads. Infiltration can occur through holes and cracks in the building envelope and around doors and fenestration framing areas.

Reducing infiltration in the building envelope can result in significant energy savings, especially in climates with severe winter and summer conditions. It also can result in improved occupant comfort, reduced moisture intrusion, and fewer air pollutants.

Exfiltration is uncontrolled outward air leakage from inside a building, including leakage through cracks, joints, and intersections, around windows and doors, and through any other exterior partition or duct penetration.

- S. **Ventilation** is the *intentional* replacement of conditioned air with unconditioned air through open windows and skylights or mechanical systems.

3.4.2. Air Sealing and Air Leakage §110.7, §150.0

3.4.2.1 Joints and Other Openings §110.7

Air leakage through joints, penetrations, cracks, holes, openings around windows, doors, walls, roofs, and floors can result in higher energy use. The following openings in the building envelope shall be caulked, gasketed, weatherstripped, or otherwise sealed:

1. Exterior joints around window and door frames (including doors between the house and garage), between interior HVAC closets and conditioned space, between attic access and conditioned space, between wall sill plates and the floor, exterior panels, and all siding materials.

Figure 3-10: Air Sealing



- 2. Openings for plumbing, electricity, and gas lines in exterior and interior walls, ceilings, and floors.
- 3. Openings in the attic floor, such as where ceiling panels meet interior walls, exterior walls, and masonry fireplaces.
- 4. Openings around exhaust ducts, such as those for clothes dryers.
- 5. All other such openings in the building envelope.



Source: Sierra Building Science

Figure 3-11: Caulking and Weatherstripping

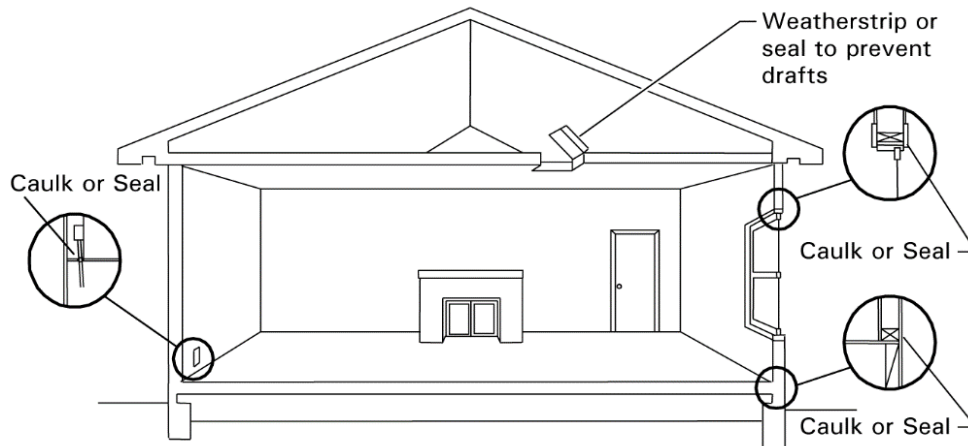

Source: California Energy Commission



Alternative strategies may be used to meet the mandatory caulking and sealing requirements for exterior walls.

These include, but are not limited to:

- 1. Stucco.
- 2. Caulking and taping all joints between wall components (for example, between slats in wood slat walls).
- 3. Building wraps.
- 4. Rigid wall insulation installed continuously on the exterior of the building with all joints taped, gasketed, or otherwise sealed.

3.4.2.2 Fireplaces, Decorative Gas Appliances, and Gas Logs §150.0(e)

The Energy Standards have mandatory requirements to limit infiltration associated with fireplaces, decorative gas appliances, and gas logs. Reduced infiltration is a benefit when the fireplace is not operating (the majority of the time for most homes).

3.4.3 Roofing Products §10-113, §110.8(i), §150.1(c)11

In general, light-colored, high-reflectance surfaces reflect solar energy (visible light and invisible infrared and ultraviolet radiation) and stay cooler than darker surfaces that absorb the sun’s energy and become heated. The Energy Standards prescribe cool roof radiative properties for low-sloped and steep-sloped roofs. Low-sloped roofs receive more solar radiation than steep-sloped roofs in the summer when the sun is higher in the sky.

Roofing products installed to take compliance credit or meet the prescriptive requirements for reflectance and emittance shall be rated by the Cool Roof Rating Council (CRRC) and labeled appropriately by the roofing manufacturer for solar reflectance and thermal emittance. The solar reflectance and thermal emittance properties are rated and listed by the Cool Roof Rating Council at (www.coolroofs.org/).

3.4.3.1 Product Labels §10-113

Figure 3-12 shows a sample Cool Roof Rating Council product label. The label includes solar reflectance and thermal emittance values.

Figure 3-12: Sample CRRC Product Label and Information

	<u>Initial</u>	<u>Weathered</u>	
	Solar Reflectance	0.00	Pending
	Thermal Emittance	0.00	Pending
	Rated Product ID Number	-----	
	Licensed Seller ID Number	-----	
	Classification	Production Line	
<p>Cool Roof Rating Council ratings are determined for a fixed set of conditions, and may not be appropriate for determining seasonal energy performance. The actual effect of solar reflectance and thermal emittance on building performance may vary.</p> <p>Manufacturer of product stipulates that these ratings were determined in accordance with the applicable Cool Roof Rating Council procedures.</p>			

Source: Cool Roof Rating Council

Solar reflectance and thermal emittance are measured from 0 to 1; the higher the value, the "cooler" the roof. There are numerous roofing materials in a wide range of colors that have adequate cool roof properties. Reducing heat gains through the roof will reduce the cooling load of the home, resulting in reduced air-conditioned energy needed to maintain occupant comfort. High-emitting roof surfaces reject absorbed heat quickly (upward and out of the building) than roof surfaces with low-emitting properties.

Solar Reflectance (SR). There are three solar reflectance measurements:

1. Initial solar reflectance
2. Three-year aged solar reflectance
3. Accelerated aged solar reflectance

All requirements of the Energy Standards are based on the three-year aged solar reflectance. If the aged SR value is not available in the CRRC’s Rated Product Directory, then the aged value shall be derived from the CRRC aged value equation (using the initial value for solar reflectance) or an accelerated process. Until the appropriate aged-rated value for the reflectance is posted in the directory, the equation below can be used to calculate the aged rated solar reflectance or a new method of testing is used to find the accelerated solar reflectance.

Calculating Aged Solar Reflectance From Initial Reflectance

Equation 3-1: $\text{Aged Reflectance}_{\text{calculated}} = (0.2 + \beta[\rho_{\text{initial}} - 0.2])$

Where:

ρ_{initial} = Initial Reflectance listed in the CRRC Rated Product Directory

β = soiling resistance which is listed in Table 3-6

Table 3-6: Values of Soiling Resistance β by Product Type

PRODUCT TYPE	β
Field-applied coating	0.65
Other	0.70

Thermal Emittance (TE). The Energy Standards do not distinguish between initial and aged thermal emittance, meaning either value can be used to demonstrate compliance with the Energy Standards.



What is Solar Reflectance Index (SRI)?

An alternative to the aged solar reflectance and thermal emittance required values is to use the Solar Reflectance Index (SRI) to show compliance. A calculator has been produced to calculate the SRI by inputting the three-year aged solar reflectance and thermal emittance of the desired roofing material.

The calculator can be found at <http://www.energy.ca.gov/title24/2019standards>.

By using the SRI alternative, a cool roof may comply with a lower emittance, as long as the aged reflectance is higher, and vice versa.

Example 3-14: ENERGY STAR® Roofing Products

Question: I am a salesperson who represents several roofing products. Many of them are on the ENERGY STAR® list published by the U.S. Environmental Protection Agency (EPA) for cool roofing materials. Is this sufficient to meet the Energy Standards?

Answer: No. ENERGY STAR has different requirements than the Energy Standards for reflectance and *no* requirements for emittance. Per §10-113, the Cool Roof Rating Council (www.coolroofs.org) is the only entity recognized by the California Energy Commission to determine what qualifies as a cool roof.

Example 3-15: Certifying Products With the Cool Roof Rating Council (CRRC)

Question: How does a product get CRRC cool roof certification?

Answer: CRRC publishes its certification procedures in the CRRC-1 Program Manual, available for free at www.coolroofs.org or by calling CRRC at (866) 465-2523 (toll free within the USA) or (510)-485-7176. Anyone new to the certification process and wishing to have one or more products certified should contact CRRC by phone or by email at info@coolroofs.org. Working with CRRC is strongly recommended; staff walks interested parties through the procedures.

Example 3-16: Reflectance vs. Emittance

Question: I understand reflectance, but what is emittance?

Answer: Material that reflects the sun's energy will still absorb some of that energy as heat; there are no perfectly reflecting materials being used for roofing. The absorbed heat is given off (emitted) to the environment in varying amounts depending on the materials and surface types. This emittance is given a value between 0 and 1, and this value represents a comparison (ratio) between what a given material or surface emits and what a perfect blackbody emitter would emit at the same temperature.

A higher emittance value means more energy is released from the material or surface; scientists refer to this emitted energy as *thermal radiation*. *Emittance* is a measure of the relative efficiency with which a material, surface, or body can cool itself by radiation. Lower-emitting materials become relatively hotter due to holding in heat. Roof materials with low emittance hold onto more solar energy as heat, and that held heat can be given off downward into the building. More heat in the building increases the need for air conditioning for comfort. A cool roof system that reflects solar radiation (has high reflectance) and emits thermal radiation well (has high emittance) will result in a cooler roof and a cooler building with lower air-conditioning costs.

3.4.3.2 Mandatory Requirements

Field-Applied Liquid Coatings §110.8(i)4

There are several liquid products, including elastomeric coatings and white acrylic coatings, that qualify for field-applied liquid coatings. The Energy Standards specify minimum performance and durability requirements for field-applied liquid coatings. These requirements do not apply to industrial coatings that are factory-applied, such as metal roof panels. The requirements address elongation, tensile strength, permeance (rate of water vapor transmission), and accelerated weathering. The requirements depend on the type of coating and are described here in greater detail. Liquid roof coatings applied to low-sloped roofs in the field as the top surface of a roof covering shall comply with the following mandatory requirements and descriptions.

Aluminum-Pigmented Asphalt Roof Coatings. Aluminum-pigmented coatings are silver-colored coatings that are commonly applied to modified bitumen and other roofing products. The coating has aluminum pigments that float to the surface of the coating while it is setting, providing a shiny and reflective surface. Because of the shiny surface and the physical properties of aluminum, these coatings have a thermal emittance below 0.75, which is the minimum rating for prescriptive compliance.

This class of field-applied liquid coatings shall be applied across the entire surface of the roof and meet the dry mil thickness or coverage recommended by the manufacturer, depending on the substrate on which the coating will be applied. The aluminum-pigmented asphalt roof coatings shall be manufactured in accordance with ASTM D2824. Standard specification is also required for aluminum-pigmented asphalt roof coatings, nonfibered, asbestos-fibered, and fibered without asbestos that are suitable for application to roofing or masonry surfaces by brush or spray, and installed in accordance with ASTM D3805, *Standard Guide for Application of Aluminum-Pigmented Asphalt Roof Coatings*.

Cement-Based Roof Coatings. This class of coatings consists of a layer of cement that may be applied to almost any type of roofing. Cement-based coatings shall be applied across the entire roof surface to meet the dry mil thickness or coverage

recommended by the manufacturer. Cement-based coatings shall be manufactured to contain no less than 20 percent Portland cement and meet the requirements of ASTM D822, ASTM C1583, and ASTM D5870.

Other Field-Applied Liquid Coatings. Other field-applied liquid coatings include elastomeric and acrylic-based coatings. These coatings must be applied across the entire roof surface to meet the dry mil thickness or coverage recommended by the manufacturer, depending on the substrate on which the coating will be applied. The field-applied liquid coatings must be tested to meet several performance and durability requirements as specified in Table 110.8-C of the Energy Standards or the minimum performance requirements of ASTM C836, D3468, or D6694, whichever are appropriate to the coating material.

3.4.3.3 Prescriptive Requirements §150.1(c)11

Steep-sloped and low-sloped energy-efficient cool roofs are prescriptively required in some climate zones. The prescriptive requirement is based on an aged solar reflectance and thermal emittance tested value from the Cool Roof Rating Council (CRRC). If a cool roof is being installed to comply with the Energy Standards, it must meet mandatory product and labeling requirements.



Table 3-7: Prescriptive Cool Roof Requirements

Prescriptive Cool Roof Requirements		Solar Reflectance and Thermal Emittance Values		SRI
Roof Type	Climate Zone	Minimum Three-Year Solar Reflectance	Minimum Thermal Emittance	Minimum SRI
Steep-sloped	10 through 15	0.20	0.75	16
Low-sloped	13 and 15	0.63	0.75	75

There are two exceptions to meeting these prescriptive requirements:

1. Roof area with building-integrated photovoltaic panels or building-integrated solar thermal panels.

OR

2. Roof constructions that have a weight of at least 25 lb/ft².

The project could choose to pursue the performance approach and trade off the prescriptive cool roof requirements. See Section 3.6 and Chapter 8 for more on the performance approach.

3.4.3.4 Compliance and Enforcement

The plans examiner should ensure that the solar reflectance and thermal emittance values documented on the CF1R-ENV-04 are specified on the building plans at the time of permit application.

The inspector can verify that the values on the CRRC label for the installed roof product meet or exceed the solar reflectance and thermal emittance values on the CF1R compliance document.



If a manufacturer does not obtain a CRRC certificate for its roofing products, the following default aged solar reflectance and thermal emittance values must be used for compliance:

1. For asphalt shingles: 0.08 aged SR and 0.75 TE
2. For all other roofing products: 0.10 aged SR and 0.75 TE

3.4.4 Radiant Barriers §110.8(j), §150.1(c)2

3.4.4.1 Mandatory Requirements §110.8(j)



When a radiant barrier is installed, the product must meet mandatory requirements in §110.8(j).

The radiant barrier must have an emittance of 0.05 or less. The product must be tested according to ASTM C1371 or ASTM E408 and must be certified by the California Bureau of Electronic and Appliance Repair, Home Furnishings and Thermal Insulation and listed in its Consumer Guide and Directory of Certified Insulation Material, at

http://www.bearhfti.ca.gov/industry/thermal_insulation.shtml.

3.4.4.2 Prescriptive Requirements §150.1(c)2, RA4.2.1

The prescriptive requirements call for Option C vented attics to have a radiant barrier in Climate Zones 2 through 15, while Option B vented attics only require a radiant barrier in Climate Zones 2, 3, and 5 through 7. The radiant barrier is a reflective material that reduces radiant heat transfer into the attic caused by solar heat gain in the roof.

Installation. The most common way of meeting the radiant barrier requirement is to use roof sheathing that has a radiant barrier bonded to it by the manufacturer. Some oriented strand board (OSB) products have a factory-applied radiant barrier. The sheathing is installed with the radiant barrier (shiny side) facing down toward the attic space.

Alternatively, a radiant barrier material that meets the same ASTM test and moisture perforation requirements that apply to factory-laminated foil can be field-laminated. Field lamination must use a secure mechanical means of holding the foil-type material to the bottom of the roof decking such as staples or nails that do not

penetrate all the way through the roof deck material. Roofs with gable ends must have a radiant barrier installed on the gable ends to meet the radiant barrier requirement.

Other acceptable methods are to drape a foil type radiant barrier over the top of the top chords before the sheathing is installed, stapling the radiant barrier between the top chords after the sheathing is installed, and stapling the radiant barrier to the underside of the truss/rafters (top chord). For these installation methods, the foil must be installed with spacing requirements as described in Residential Reference Appendices RA4.2.1.

Installation of radiant barriers is somewhat more challenging in the case of closed rafter spaces, particularly when roof sheathing is installed that does not include a laminated foil-type radiant barrier. Radiant barrier foil material may be field-laminated after the sheathing has been installed by “laminating” the foil to the roof sheathing between framing members. This construction type is described in the Residential Reference Appendices RA4.2.1.1. See Figure 3-13 for drawings of radiant barrier installation methods.

For closed rafter spaces, such as a cathedral ceiling, the required air space for radiant barriers shall be provided, and must meet the ventilation requirements of CBC, Title 24, Part 2.5, Section R806.1.

Figure 3-13: Methods of Installation for Radiant Barriers

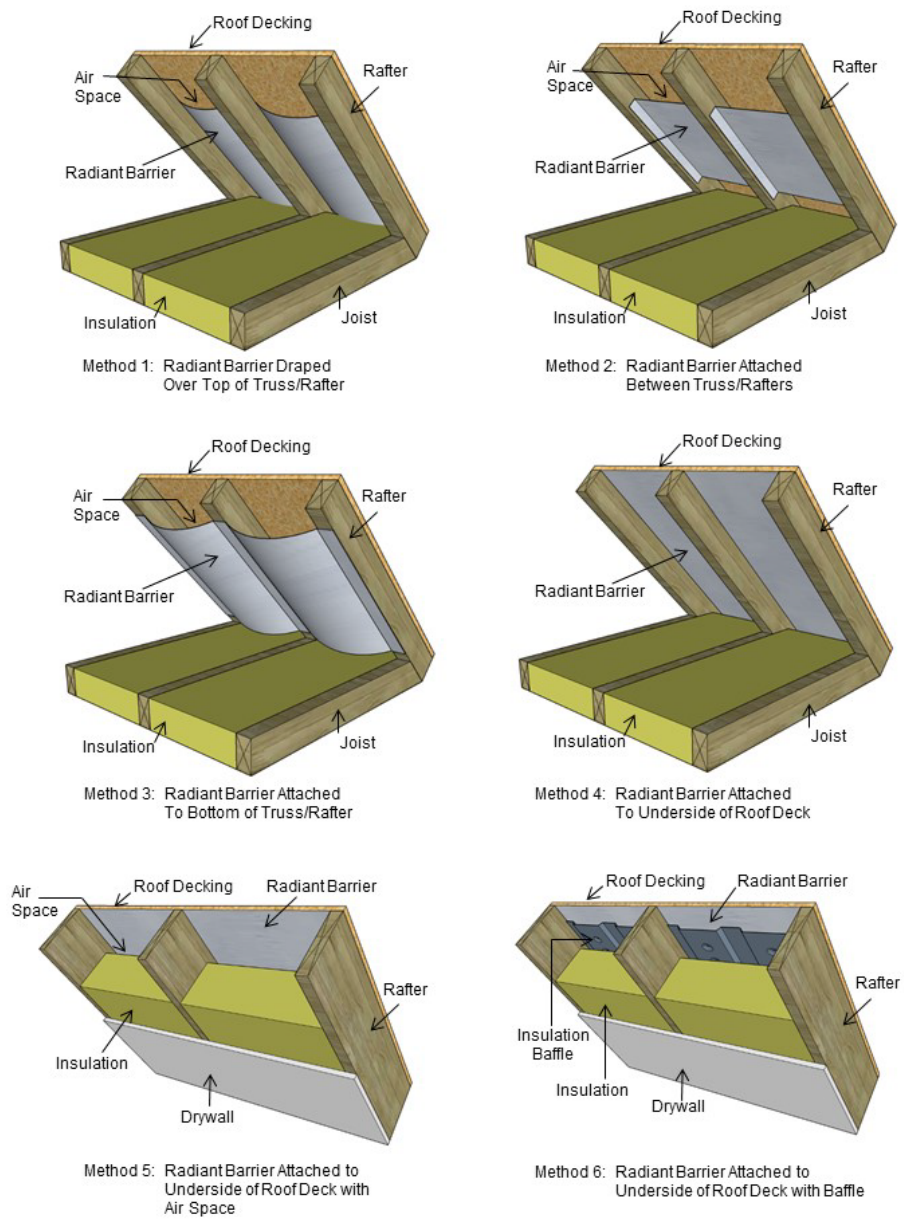

Source: California Energy Commission



Radiant Barriers in the Performance Approach

In the performance approach, radiant barriers are modeled apart from the U-factor. The duct efficiency also is affected by the presence of a radiant barrier when using the performance approach. See more in Section 3.6 and Chapter 8.

3.4.5 Vapor Retarder §150.0(g) and RA4.5.1



When is a vapor retarder required?

In Climate Zones 14 and 16, a continuous Class I or Class II vapor retarder, lapped or joint sealed, must be installed on the conditioned-space side of all insulation in all exterior walls, on the roof decks of vented attics with above-deck or below-deck air-permeable insulation, and in unvented attics with air-permeable insulation.

Buildings with unvented or controlled-ventilation crawl spaces in all climates zones must have a Class I or Class II vapor retarder placed over the earth floor of the crawl space to reduce moisture entry and protect insulation from condensation in accordance with RA4.5.1.

3.4.5.1 Product Requirements

Vapor retarder class is a measure of the ability of a material or assembly to limit the amount of moisture that passes through the material or assembly. Vapor retarder classes are defined in Section 202 of the California Building Code (CBC). Testing for vapor retarder class is defined using the desiccant method of ASTM E96.

1. Class I: 0.1 perm or less
2. Class II: $0.1 < \text{perm} \leq 1.0$ perm
3. Class III: $1.0 < \text{perm} \leq 10$ perm

There are many product types having tested vapor retarder performance. Some common examples include the following:

1. Foil and other facings on gypsum board can provide moisture resistance, and product literature should always be checked to ensure conformance to ASTM E96.
2. The kraft paper used as facing on thermal batt insulation material is typically a Class II vapor retarder. Faced batts may have flanges for fastening to assembly framing. Fastening flanges may be face- or inset-stapled or not stapled at all, as the flanges provide no moisture control. Face stapling of flanged thermal batts helps ensure the insulation material is installed fully and properly within

the framed cavity. Flangeless batts are also common and require no fastening as these materials maintain installation integrity through friction-fitting within the cavity of framed assemblies. In all cases, the insulation must be installed properly. See Figure 3-14.

3. Interior painted surfaces may also serve as vapor retarders if the paint product has been tested and shown to comply with the vapor retarder requirements. The effectiveness of vapor retarder paint depends upon the installed thickness (in mils). These products often require more than one layer to achieve the tested perm rating, and care must be shown by the installer of the paint and for inspection by the building official.
4. Closed-cell spray polyurethane foam (ccSPF) products can provide Class I or Class II vapor retarder performance, depending on thickness.

For all types of vapor retarders, care should be taken to seal penetrations, such as electric outlets on exterior walls.

Figure 3-14: Typical Kraft-Faced Vapor Retarder Facing

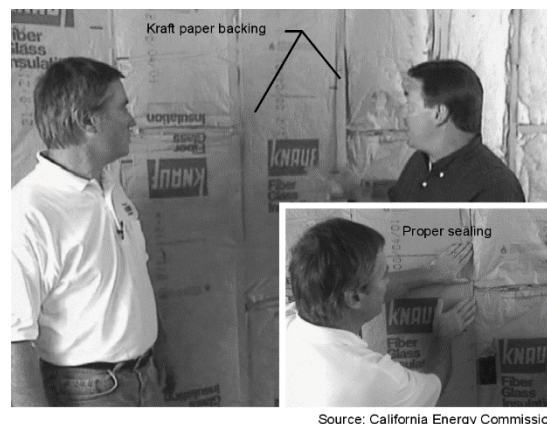



3.5 Insulation Products

The Energy Standards encourage the use of energy-saving techniques and designs for showing compliance. Insulation is one of the least expensive measures to improve building energy efficiency. Insulation requires no maintenance, helps improve indoor comfort, and provides excellent sound control. Adding extra insulation later is more expensive than maximizing insulation levels at the beginning of construction. Innovative construction techniques and building products are being used more often by designers and builders who recognize the value of energy-efficient, high-performance buildings.

When the performance compliance method is used, an energy credit can be taken for design strategies that reduce building energy use below the standard design energy budget (compliance credit). Some strategies may require third-party verification by a HERS Rater; others do not. For more on the performance method, see Section 3.6 and Chapter 8.

Table 3-8: Relevant Sections in the Energy Standards

	MANDATORY	PRESCRIPTIVE	PERFORMANCE
			
Insulation	§110.8(a) - (d), §110.8(g) - (h), §150.0(a) - (d), §150.0(f)	§150.1(c)1 Table 150.1-A	§150.1(a), §150.1(b)

3.5.1. Types of Insulation Products

There are four basic types of insulation or “insulation systems” installed in residential buildings: batt and blanket, loose-fill, spray polyurethane foam (SPF), and rigid insulation. The use varies based on the design and type of construction.

3.5.1.1 Batt and Blanket

Batt and blanket insulation is made of mineral fiber and mineral wool (processed fiberglass, rock, slag wool); animal wool or cotton-based products; or cellulose materials. These products are used to insulate below floors, above ceilings, below roofs, and within walls. They offer ease of installation with R-values set by the manufacturer based on size and thickness. They are available with facings, some serve as vapor retarders, and have flanges to aid in installation to framed assemblies. Many are available as unfaced material and can be easily friction-fitted into framed cavities.

Batt and blanket insulation allows easy inspection, and installation errors can readily be identified and remedied, including breeches in the air barrier system that allow air leakage.



Care should always be taken to install insulation properly, filling the entire cavity and butting ends or sides of the batt material to ensure uniformity of installation. Batt and blanket insulation material must be delaminated or cut to allow for wiring, plumbing, and other penetrations within the cavity. See Section 3.5.

3.5.1.2 Loose-Fill Insulation

Loose-fill is insulation that has a pneumatic or blown installation process, including cellulose, fiberglass, mineral wool and natural wool (animal or cotton-based products). Blown wall insulation can be an effective way to deal with the irregularities of wall cavities, especially the spaces around pipes, electric cables, junction boxes, and other equipment embedded in wall cavities (see Figure 3-15). The R-value of blown wall insulation material installed in closed cavities is determined by the installed thickness and density. This differs from manufactured products such as fiberglass or mineral wool batts for which the R-value has been tested and arrives at the construction site in preformed lengths and thicknesses with set R-value thicknesses.

When installed in floors, walls, and other assemblies, these fibrous insulations are held in place in one of three ways:

1. Preinstalled netting or fabric
2. Use of existing cavity walls
3. Use of integral adhesives



Blown wall insulation must be thoroughly checked to ensure the R-value is achieved. R-value depends on the installed density of the material at the building site, and the building official should ensure that the installed density meets manufacturer specifications. See Section 3.5.

Figure 3-15: Cellulose-Insulated Wall



Source: California Energy Commission

In closed cavities:

- A line of sight down a wall section can hide imperfections in the installation, leading to underachieving stated R-values.
- Depressions and voids within the insulated cavity are areas lacking in R-value performance.
- Where netting is used, overspraying can result in a higher installed density (higher R-value) but can be troublesome for attaching gypsum board to wall framing.
- Where cavities have been underfilled, there may be voids or “soft” areas under the netting. These areas must be corrected by adding insulation, or the area must be removed, and new material must be blown into the cavity.

In open cavities (attic floor or open wall):

- No netting or preexisting wall cladding is needed (Figure 3-16).
- In open horizontal applications, such as attic floors, no adhesives are used, and the R-value is verified by thickness and rated coverage.
- In open vertical applications, integral adhesives are used to hold the fibers in place. Water-activated adhesives are used for moist-spray cellulose, and water or polymer adhesives are used for fiberglass loose-fill applications. The fiber and/or adhesive formulation cause the insulation to adhere to itself and stick to surfaces of the wall cavity.
- Excess insulation that extends past the wall cavity is scraped off and recycled.

Figure 3-16: Attic Floor



Source: California Energy Commission

3.5.1.3 Spray Polyurethane Foam (SPF)

SPF is a two-part, liquid-foamed thermoset plastic (such as polyurethane). Polyurethane is formed by the reaction of an isocyanate and a polyol. Blowing agents, catalysts, and surfactants are added to develop a cellular structure before the polyurethane mixture cures. At application, the SPF material forms in place to provide insulation, an air seal, and, in closed-cell SPF, an integral vapor retarder and water barrier.

SPF insulation is a two-component reactive system mixed at a spray gun or a single-component system that cures by exposure to humidity. The liquid is sprayed through a nozzle into the wall, roof, ceiling, and floor cavities. SPF insulation can be formulated to have specific physical properties, such as density, compressive strength, fire resistance, and R-value.

SPF insulation is spray-applied to adhere fully to the substrate and other framing faces to form a complete air seal within the construction cavities.



SPF must be separated from the interior of the building, including attic spaces, by an approved thermal barrier complying with Section 316.4 of the CRC.

There are two common types of SPF insulation:

A. Low-Density Open-Cell SPF (ocSPF)

Insulation: A spray-applied polyurethane foam insulation having an open cellular structure resulting in an installed nominal density of 0.4 to 1.5 pounds per cubic foot (pcf), ocSPF has been assigned a default R-value of 3.6 per inch for compliance, but some products can achieve higher R-values. The ocSPF insulation is sprayed then expands to fill the framed cavity (Figure 3-17). Excess insulation may be trimmed by a special tool to simplify interior cladding installation. The average thickness of the foam insulation must meet or exceed the required R-value. Depressions in the foam insulation surface shall not be greater than 1/2-inch of the required thickness, provided these depressions do not exceed 10 percent of the surface area being insulated. Note: If using the default R-value of 3.6 per inch, the entire wall cavity must be filled to achieve the mandatory minimum wall insulation requirements for 2x4 and 2x6 framing.

Figure 3-17: Open-Cell SPF Installed in Wall Cavity



Source: SPFA

B. Medium-Density Closed-Cell SPF (ccSPF)

Insulation: A spray-applied polyurethane foam insulation having a closed cellular structure resulting in an installed nominal density of greater than 1.5 to less than 2.5 pounds per cubic foot (pcf), CcSPF has been assigned a default R-value of 5.8 per inch for compliance, but some products can achieve higher R-values. The average thickness of the foam insulation must meet or exceed the required R-value. Depressions in the surface of the foam insulation shall not be greater than 1/2-inch of the required thickness at any given point of the surface area being insulated. CcSPF is not required to fill the cavity (Figure 3-18).

Figure 3-18: Closed-Cell SPF Installation in a Wall Cavity



Source: SPFA



SPF R-value depends on the installed thickness, and the building official should ensure the thickness and uniformity of the SPF material within each cavity of framed assemblies meets manufacturer specifications.

Table 3-9: Required Thickness of SPF Insulation to Achieve Default R-Values

Thickness of SPF Insulation	R11	R13	R15	R19	R20	R21	R22	R25	R30	R38
Required Thickness of ccSPF Insulation (inches)	2.00	2.25	2.75	3.25	3.50	3.75	4.00	4.50	5.25	6.75
Required Thickness of ocSPF Insulation (inches)	3.00	3.50	4.20	5.30	5.50	5.80	6.10	6.90	8.30	10.6

Equation 3-2: Alternative Calculation for Total R-Value:

Thickness of insulation	X	"Tested R-value per inch" as listed in the Table of R-values or R-value Chart from the manufacturer's current ICC Evaluation Service Report (ESR) that shows compliance with <i>Acceptance Criteria for Spray-Applied Foam Plastic Insulation--AC377</i>
-------------------------	---	--

Overall assembly U-factors are determined by selecting the assembly type, framing configuration, and cavity insulation rating from the appropriate JA4 table, other approved method specified in JA4, or using the Energy Commission-approved compliance simulation software.

3.5.1.4 Rigid Insulation

Rigid board insulation sheathing is made from fiberglass, mineral wool, expanded polystyrene (EPS), extruded polystyrene (XPS), polyisocyanurate (ISO), or polyurethane (PUR). It varies in thickness, and some products can provide up to R-6 per inch of thickness.

This type of insulation is used for above-roof decks, exterior walls, cathedral ceilings, basement walls; as perimeter insulation at concrete slab edges; and to insulate special framing situations such as window and door headers and around metal seismic bracing. Rigid board insulation may also be integral to exterior siding materials. Properly sealed rigid insulation can be used continuously across an envelope surface to reduce air infiltration and exfiltration, and thermal bridging at framing.

Figure 3-19: Properly Installed Rigid Insulation With Sealant Tape



Source: U.S. Environmental Protection Agency



Proper installation of continuous rigid insulation may include button cap nails, furring strips, flashing, sealant tape, and design of the drainage plane. See Figure 3-19.

The 2019 California Building Code (CBC) provides guidance on fastener penetration depth, diameter, and spacing for exterior foam sheathing in Section R703.11.2. CRC Table 703.15.1, reproduced below in Figure 3-20, shows the fastener spacing for cladding attachment over foam sheathing to wood framing.

Figure 3-20: Fastening Requirements Over Foam Sheathing

TABLE R703.15.1
CLADDING MINIMUM FASTENING REQUIREMENTS FOR DIRECT ATTACHMENT
OVER FOAM PLASTIC SHEATHING TO SUPPORT CLADDING WEIGHT^a

CLADDING FASTENER THROUGH FOAM SHEATHING	CLADDING FASTENER TYPE AND MINIMUM SIZE ^b	CLADDING FASTENER VERTICAL SPACING (inches)	MAXIMUM THICKNESS OF FOAM SHEATHING ^c (inches)					
			16" o.c. Fastener Horizontal Spacing			24" o.c. Fastener Horizontal Spacing		
			Cladding Weight:			Cladding Weight:		
			3 psf	11 psf	25 psf	3 psf	11 psf	25 psf
Wood Framing (minimum 1 1/4-inch penetration)	0.113" diameter nail	6	2	1	DR	2	0.75	DR
		8	2	1	DR	2	0.5	DR
		12	2	0.5	DR	2	DR	DR
	0.120" diameter nail	6	3	1.5	0.5	3	0.75	DR
		8	3	1	DR	3	0.5	DR
		12	3	0.5	DR	2	DR	DR
	0.131" diameter nail	6	4	2	0.75	4	1	DR
		8	4	1.5	0.5	4	0.75	DR
		12	4	0.75	DR	2	0.5	DR
	0.162" diameter nail	6	4	4	1.5	4	2	1
		8	4	3	1	4	1.5	0.75
		12	4	2	0.75	4	1	DR

For SI: 1 inch = 25.4 mm, 1 pound per square foot = 0.0479 kPa, 1 pound per square inch = 6.895 kPa.
DR = Design required.
o.c. = On center.

- a. Wood framing shall be Spruce-pine-fir or any wood species with a specific gravity of 0.42 or greater in accordance with AWC NDS.
- b. Nail fasteners shall comply with ASTM F 1667, except nail length shall be permitted to exceed ASTM F 1667 standard lengths.
- c. Foam sheathing shall have a minimum compressive strength of 15 psi in accordance with ASTM C 578 or ASTM C 1289.

Source: 2019 California Building Code

3.5.2. Insulation Product Requirements §110.8(a)

Manufacturers must certify that insulating materials comply with the *California Quality Standards for Insulating Materials* (CCR, Title 24, Part 12, Chapters 12-13), which ensure that insulation sold or installed in California performs according to stated R-values and meets minimum quality, health, and safety standards.



Builders and enforcement agencies shall use the California Department of Consumer Affairs *Directory of Certified Insulation Material* to verify the certification of the insulating material. If an insulating product is not listed in the current edition of the directory, contact the Department of Consumer Affairs, Bureau of Electronic and Appliance Repair, Home Furnishings and Thermal Insulation, at (916) 999-2041 or by email at bear.enf@dca.ca.gov.

Urea Formaldehyde Foam Insulation §110.8(b)

The mandatory measures restrict the use of urea formaldehyde foam insulation. The restrictions are intended to limit human exposure to formaldehyde, a volatile and harmful organic chemical.

If foam insulation is used that has urea formaldehyde, it must be installed on the exterior side of the wall (not in the cavity of framed walls), and a continuous vapor retarder must be placed in the wall construction to isolate the insulation from the

interior of the space. The vapor retarder must be 4-mil- thick (0.1 mm) polyethylene or equivalent.

Flame Spread Rating of Insulation §110.8(c)

The *California Quality Standards for Insulating Materials* requires that exposed facings on insulation material be fire resistant and tested and certified not to exceed a flame spread index of 25 and a smoke development index of 450. Insulation facings must be in contact with the finished assembly surface or they are considered exposed applications and cannot be installed. Flame spread indexes and smoke development indexes are shown on the insulation or packaging material or may be obtained from the manufacturer.

3.5.3 Ceiling and Roof Insulation §110.8(d), §150(a)

3.5.3.1 Loose Fill Insulation in the Attic §150.0(b)

Loose fill insulation must be blown in evenly, and insulation levels must be documented on the certificate of installation (CF2R). The insulation level can be verified by checking that the depth of insulation conforms to the manufacturer's coverage chart for achieving the required R-value. The insulation also must meet the manufacturer's specified minimum weight per ft² for the corresponding R-value.



When installing loose fill insulation, the following guidelines should be followed:

1. For wood trusses that provide a flat ceiling and a sloped roof, the slope of the roof should be 4:12 or greater to provide adequate access for installing the insulation. Insulation thickness near the edge of the attic will be reduced with all standard trusses, but this is acceptable as long as the average thickness is adequate to meet the minimum insulation requirement.
2. If the ceiling is sloped (for instance, with scissor trusses), loose fill insulation can be used as long as the slope of the ceiling is no more than 4:12. If the ceiling slope is greater than 4:12, loose fill should be used only if the insulation manufacturer will certify the installation for the slope of the ceiling.
3. At the apex of the truss, a clearance of at least 30 inches should be provided to simplify installation and inspection.

3.5.3.2 Wet Insulation Systems §110.8(h)

Wet insulation systems are roofing systems where the insulation is installed above the waterproof membrane of the roof. Water can penetrate this insulation material and affect the energy performance of the roofing assembly in wet and cool climates. In Climate Zones 1 and 16, the insulating R-value of continuous insulation materials installed above the waterproof membrane of the roof must be multiplied by 0.8, and installers must use the result value in choosing the table column in Reference Joint

Appendix JA4 for determining assembly U-factor (when using the Joint Appendix JA4 table to comply). See the footnotes for Tables 4.2.1 through 4.2.7 in the Reference Joint Appendix JA4.

3.5.3.3 Recessed Luminaires §150.0(k)1C

Luminaires recessed in insulated ceilings can create thermal bridging through the assembly. Not only does this degrade the performance of the ceiling assembly, but it can permit condensation on a cold surface of the luminaire if exposed to moist air, as in a bathroom. Refer to the Lighting Chapter 6 for more information regarding the applicable requirements for recessed luminaires.



Luminaires recessed in insulated ceilings must meet three requirements.

1. They must be listed as defined in the Article 100 of the California Electric Code for zero clearance insulation contact (IC) by Underwriters Laboratories or other testing/rating laboratories recognized by the International Code Council (ICC). This enables insulation to be in direct contact with the luminaire.
2. The luminaire must have a label certified as per §150.0(k)1Cii for airtight (AT) construction. Airtight construction means that leakage through the luminaire will not exceed 2.0 cfm when exposed to a 75 Pa pressure difference, when tested in accordance with ASTM E283.
3. The luminaire must be sealed with a gasket or caulk between the housing and ceiling.

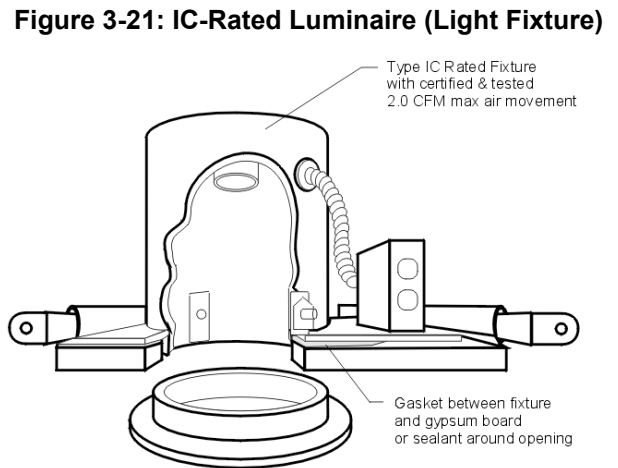

Source: California Energy Commission

3.5.3.4 Mandatory Requirements

Wood-framed roof/ceiling construction assemblies must have at least R-22 insulation or a maximum U-factor of 0.043 based on 16-inch-on-center wood-framed rafter roofs, as determined from JA4. Some areas of the roof/ceiling can be greater than the maximum U-factor as long as other areas have a U-factor lower than the requirement and the weighted average U-factor for the overall ceiling/roof is 0.043 or less.

Metal-framed and roof/ceiling constructions other than wood-framed must have a U-factor of 0.043 or less to comply with the mandatory measure. If the insulation is not penetrated by framing, such as rigid insulation laid over a structural deck, then the rigid insulation can actually have a rated R-value of less than R-22 so long as the total roof/ceiling assembly U-factor is not greater than U-0.043.

3.5.3.5 Prescriptive Requirements §150.1(c) and Table 150.1-A

The 2019 Energy Standards are designed to offer flexibility to the builders and designers of residential new construction in terms of achieving the intended energy efficiency targets. As such, the Energy Standards offer several options for achieving one of two design objectives related to improving energy performance of homes built with ventilated attics in Climate Zones 4, 8-16, as shown in Figure 3-22.

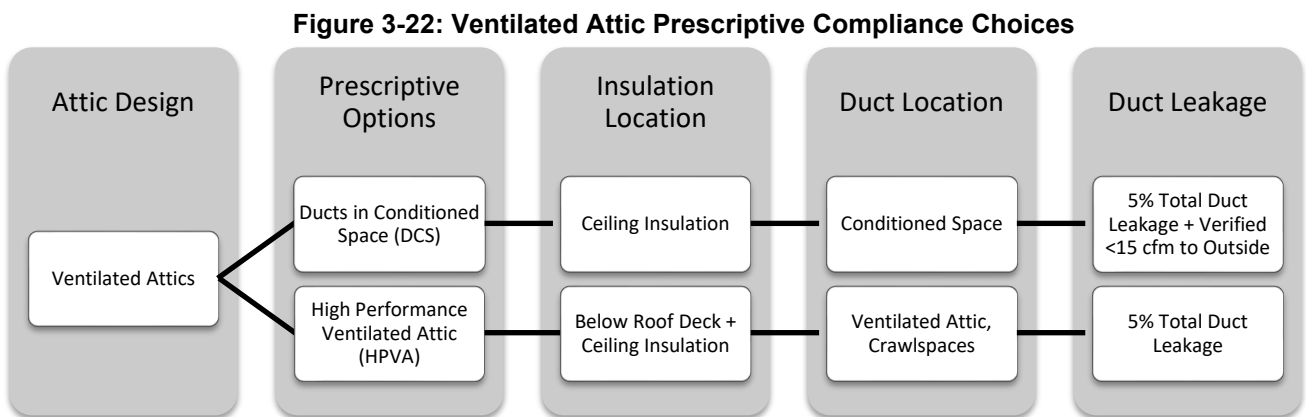

High Performance Ventiladed Attic (HPVA). This approach reduces temperature differences between the attic space and the conditioned air being transported through ductwork in the attic. The package consists of insulation below the roof deck (Option B) in addition to insulation at the ceiling, R-8 ducts, and 5 percent total duct leakage of the nominal air handler airflow.

Ducts in Conditioned Space (DCS). Ducts and air handlers are within the thermal and air barrier envelope of the building.



The Ducts in Conditioned Space (Option C) requires field verification by a HERS Rater to meet the prescriptive requirement.

All the prescriptive requirements for HPVA or DCS are based on the assumption that the home is built with the following construction practices:

1. The attic is ventilated with an appropriate free vent area as described below.
2. The roof is constructed with standard wood rafters and trusses.

3. For HPVA, the outermost layer of the roof construction is either tiles or a roofing product installed with an air gap between it and the roof deck.
4. The air handler and ducts are in the ventilated attic for HPVA and are in conditioned space for DCS.
5. The air barrier is located at the ceiling (excludes “cathedral” sealed attic roof/ceiling systems).

If a building design does not meet all of these specifications, it must comply through the performance approach.

Example 3-17: Cathedral Ceilings

Question: If 5 percent of a roof will be a cathedral ceiling, can it still comply under the prescriptive requirements?

Answer: No. The entire attic must be a ventilated space with the building air barrier located at the ceiling with standard wood rafter trusses to comply with the prescriptive requirements. This project must comply through the performance approach.

Example 3-18: Sealed (Unventilated) Attics

Question: Does a sealed (unventilated) attic with insulation at the roof deck comply under the prescriptive requirements?

Answer: No. The entire attic must be a ventilated space with the building air barrier located at the ceiling with standard wood rafter trusses to comply with the prescriptive requirements. This project must comply through the performance approach.

Example 3-19: Insulation Above the Roof Deck

Question: Does a ventilated attic with insulation above the roof deck comply under the prescriptive requirements?

Answer: No. The insulation must be located below the roof deck between the roof rafters to comply with the prescriptive requirements. If insulation is above the roof deck, the project must comply through the performance approach.

Example 3-20: Asphalt Shingles

Question: A home with asphalt shingle roofing, having no air gap, has a ventilated attic with insulation installed below the roof deck between the roof rafters (HPVA) and at the ceiling meeting prescriptive insulation levels. Does this home comply with the prescriptive requirements?

Answer: No. The roofing product must be of a type that is installed with an air gap between the product and the roof deck, such as concrete tile, to comply with the prescriptive requirements. If a roofing product with no air gap between the product and the roof deck is installed, the project must comply through the performance approach.

Example 3-21: Gable Ends in High Performance Ventilated Attics

Question: In addition to the roof underdeck, do gable end walls in high performance ventilated attics (HPVA) need to be insulated?

Answer: No. Gable end walls do not need to be insulated when designing and installing a HPVA.

Example 3-22: Attic Insulation Placement

Question: When installing roof/ceiling insulation, does the insulation need to be installed on the entire roof/ceiling, including areas over unconditioned space?

Answer: It depends. The insulation should be installed at the roof/ceiling in one of the following ways:

- (1) If the attic is an open or undivided space, then the entire roof/ceiling should be insulated. This includes portions of the roof/ceiling over an unconditioned space such as a garage.
 - (2) If the attic has a continuous air barrier separating the attic over unconditioned space from the attic over conditioned space, then only the portions of the roof/ceiling over conditioned space should be insulated. It is recommended, but not required, that the air barrier also be insulated.
-

High Performance Ventilated Attics §150.1(c).1

This section describes the prescriptive requirements and approaches necessary for HPVA as they relate to roof/ceiling insulation. HVAC aspects of the HPVA including duct insulation and duct leakage are described in Chapter 4. Requirements and approaches to meet the ducts in conditioned space (DCS) are described in Chapter 4 of this manual.

Section 150.1(c).1 requires different values of roof and ceiling insulation, depending on whether the HPVA (Option B) or DCS (Option C) is chosen. Figure 3-23 shows a prescriptive requirements checklist for each option based on Tables 150.1-A and 150.1-B.

Figure 3-23: Prescriptive Insulation Options



High Performance Ventilated Attics		Ducts in Conditioned Space
Option B ¹ Single-Family	Option B ¹ Multifamily	Option C
<ul style="list-style-type: none"> <input type="checkbox"/> Vented attic <input type="checkbox"/> R-19 (CZ 4, 8-16) below roof deck batt, spray in cellulose/fiberglass secured with netting, or spray foam <input type="checkbox"/> R-38 (CZ 1, 2, 4, 8-16) ceiling insulation or R-30 (CZ 3, 5-7) <input type="checkbox"/> Radiant barrier (CZ 2, 3, 5-7) <input type="checkbox"/> Air space between roofing and the roof deck <input type="checkbox"/> R-6 or R-8 duct insulation (climate zone specific) <input type="checkbox"/> 5% total duct leakage 	<ul style="list-style-type: none"> <input type="checkbox"/> Vented attic <input type="checkbox"/> R-19 (CZ 4, 8-9, 11-15) or R-13 (CZ 10, 16) below roof deck batt, spray in cellulose/fiberglass secured with netting, or spray foam <input type="checkbox"/> R-38 (CZ 1, 2, 4, 8-16) ceiling insulation or R-30 (CZ 3, 5-7) <input type="checkbox"/> Radiant barrier (CZ 2, 3, 5-7) <input type="checkbox"/> Air space between roofing and the roof deck <input type="checkbox"/> R-6 or R-8 duct insulation (climate zone specific) <input type="checkbox"/> 5% total duct leakage 	<ul style="list-style-type: none"> <input type="checkbox"/> Vented attic <input type="checkbox"/> R-38 (CZ 1, 11-16) ceiling insulation or R-30 (CZ 2-10) <input type="checkbox"/> R-6 or R-8 ducts (climate zone-specific) <input type="checkbox"/> Radiant barrier (CZ 2-15) <input type="checkbox"/> HERS-verified ducts in conditioned space
Table 150.1-A Assembly Option B	Table 150.1-B Assembly Option B	Table 150.1-A/B Assembly Option C
<p>¹ Option B is the Standard Design used to set the energy budget for the Performance Approach.</p>		

Below Roof Deck Insulation Option B. In a vented attic, air-permeable or air-impermeable insulation (batt, spray foam, loose-fill cellulose, or fiberglass) should be placed **directly** below the roof deck between the truss members and secured in place to provide a thermal break for the attic space. Insulation must be in direct contact with the roof deck and secured by the insulation adhesion, facing, mechanical fasteners, wire systems, a membrane material, or netting. Batts supported with cabling or other mechanical methods from below shall have supports that are less than or equal to 16” apart and no farther than 8” from the end of the batt.

When batt thickness exceeds the depth of the roof framing members, full-width batts must be used to fit snugly and allow batts to expand beyond the framing members. Full coverage of the top chord framing members by insulation is recommended as best practice but is not required.

Figure 3-24: Details of Option B Assembly

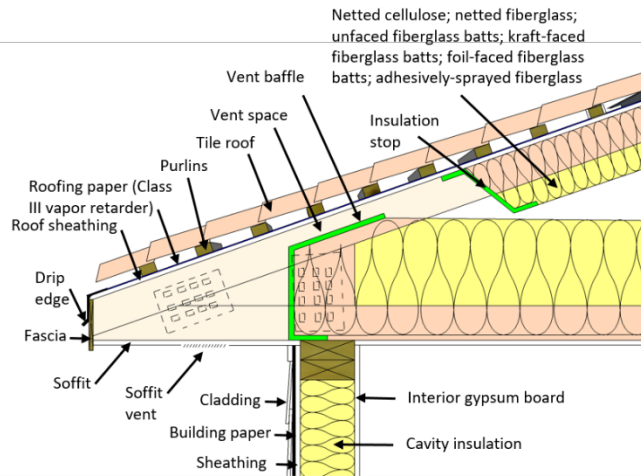

Source: California Energy Commission

Figure 3-25: Placement of Insulation Below the Roof Deck

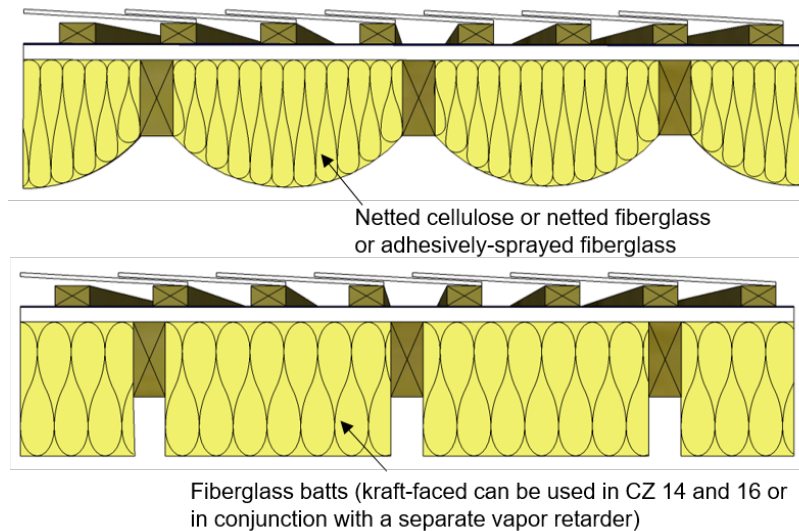

Source: California Energy Commission



When insulation is installed below the roof deck to meet the prescriptive requirements of Option B, a radiant barrier is not required. However, a draped radiant barrier may be installed to receive performance credit.

Vapor Retarders (Option B). Attic vapor retarders are not required by the Energy Standards in most climates when using spray foam, blown-in insulation, or unfaced batts, and when sufficient attic ventilation is maintained. Although not required, the use of vapor retarders can provide additional security against possible moisture buildup in attic and

framed assemblies. In Climate Zones 14 and 16, a Class I or Class II vapor retarder must be used to manage moisture¹ as stated in CBC, Title 24, Part 2.5, Section R806.2.

Attic Ventilation (Options B and C)

Proper attic ventilation occurs at two points at the roof: the soffit (or eave) vents and the ridge (or eyebrow) vents. Ridge or eyebrow venting must be maintained, as shown in Figure 3-26.

When installing insulation below the roof deck, vent baffles and insulation barriers should be used to maintain proper ventilation space. Proper airflow through the space helps remove moisture and prevents any associated issues.

Where ceiling insulation is installed next to eave or soffit vents, a rigid baffle should be installed at the top plate to direct ventilation air up and over the ceiling insulation. (See Figure 3-27.) The baffle should extend beyond the height of the ceiling insulation and should have sufficient clearance between the baffle and roof deck at the top. There are several acceptable methods for maintaining ventilation air, including preformed baffles made of either cardboard or plastic. In some cases, plywood or rigid foam baffles are used.

The California Building Code (CBC) requires a minimum vent area to be provided in roofs with attics, including enclosed rafter roofs creating cathedral or vaulted ceilings. Check with the local building jurisdiction to determine which of the two CBC ventilation requirements are to be followed:

1. CBC, Title 24, Part 2, Vol. 1, Section 1203.2 requires that the net-free ventilating area shall not be less than 1/300 of the area of the space ventilated.

Figure 3-26: Insulation Air Baffles

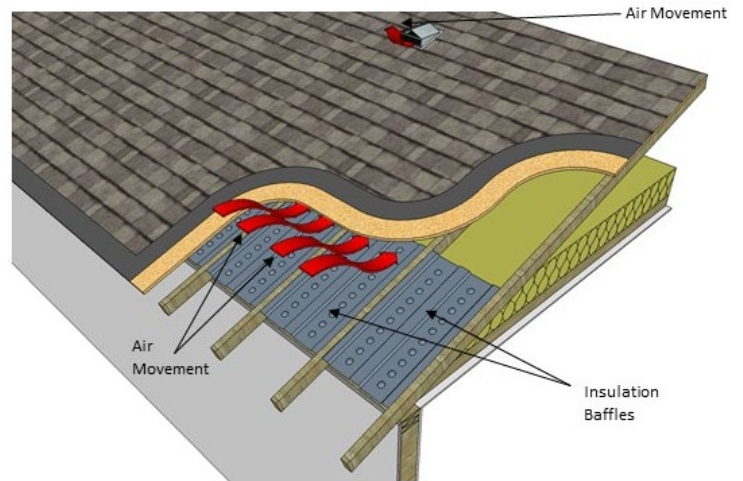

Source: Building Science Corporation

Figure 3-27: Baffles at the Eave in Attics

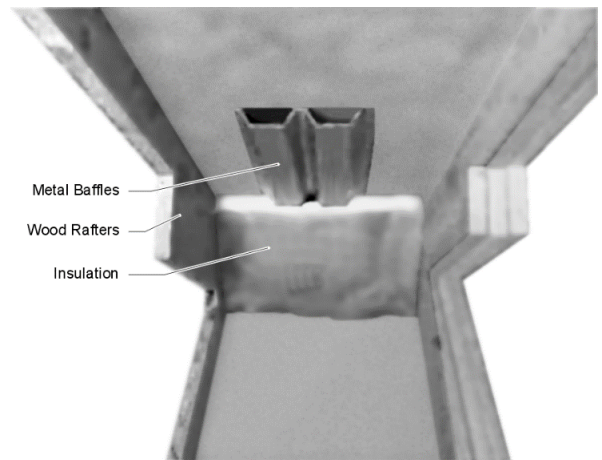

Source: California Energy Commission

. 1 Insulation Contractors Association of America. (2004). Technical Bulletin No. 6 Use of Vapor Retarders.

2. CBC, Title 24, Part 2.5, Section R806.2 requires that the net-free ventilating area shall not be less than 1/150 of the area of the space ventilated. This ratio may be reduced to 1/300 if a ceiling vapor retarder is installed in Climate Zones 14 and 16.

If meeting Option 1 above, a minimum of 40 percent and not more than 50 percent of the vents must be located in the upper portion of the space being ventilated at least 3 feet above the eave or cornice vents.

Insulation shall not block the free flow of air, and a minimum 1-inch air space shall be provided between the insulation and the roof sheathing and at the location of the vent.

Ventilated openings are covered with corrosion-resistant wire cloth screening or similar mesh material. When part of the vent area is blocked by meshes or louvers, the resulting “net-free area” of the vent must be considered to determine if ventilation requirements are met.

Many jurisdictions in California are covered by Wildland Urban Interface (WUI) regulations where specific measures for construction materials must be used to improve fire resistance for the building. These regulations require special vents that are expressly tested to resist the intrusion of flame and burning embers. Check with the building department to ensure compliance with local codes.

Example 3-23: Installation Doesn't Match Compliant Design Option

Question: A new construction project in Climate Zone 12 with HVAC ducts in the attic was designed to meet the prescriptive requirements for below roof deck and ceiling insulation. Due to miscommunication amongst the team, the roof deck insulation was not installed, and R-49 ceiling insulation was installed instead. Does this project still comply?

Answer: This project no longer meets the prescriptive requirements and must follow the performance approach. For future projects, clearly communicating the project expectations to all team members early in the construction process is the key to succeeding at this design strategy. Having a project initiation meeting with all subcontractors and team members is a best practice, at least for the first few projects, until the entire team is aware of the design needs.

Note: If the design was changed so that the roof deck has a radiant barrier and the HVAC equipment and ducts are verified to be in conditioned space, the altered design will meet the prescriptive requirements under Option C.



Tips for Successfully Implementing the High Performance Attics Requirements

- ✓ Commit to a compliance strategy early in the building design process.
- ✓ Have a kick-off meeting with builder, subcontractor, designer, energy consultant, and HERS Rater to set expectations and express the value of the design.
- ✓ Communicate strategy and schedule to subcontractors and other team members early.
- ✓ Include insulation specifications according to the CF1R on the building plans.
- ✓ Insulation contractor will install insulation below roof deck (ideally at the same time as ceiling insulation).
- ✓ All relevant subcontractors must be aware of where the air barrier is located and be conscious of where they make penetrations, especially if designing for verified ducts in conditioned space or reduced building envelope leakage.

Duct and Air Handlers Located in Conditioned Space Option C. Allows a project to place and verify that ducts are located in conditioned space instead of installing insulation at the roof deck. If complying with this option, ceiling and duct insulation must be installed at the values specified in Table 150.1-A or Table 150.1-B for Option C, and a radiant barrier is required in most climate zones.

HERS Verification (Option C). Simply locating ducts in conditioned space does not qualify for this requirement; a HERS Rater must test and verify for low leakage ducts within conditioned space and that the ducts are insulated to a level required in Table 150.1-A or Table 150.1-B of the Energy Standards.



Design strategies that can be used to prescriptively comply with Option C include dropped ceilings (dropped soffit), plenum or scissor truss to create a conditioned plenum box, and open-web floor truss. The key is that the ducts and equipment are placed within the air barrier of the building. Locating ducts within an unvented attic does not meet Option C requirements.

Ceiling Insulation (Options B and C). Insulation coverage should extend far enough to the outside walls to cover the bottom chord of the truss. However, insulation should not block eave vents in attics because the flow of air through the attic space helps remove moisture that can build up in the attic and condense on the underside of the roof deck. This can cause structural damage and reduce the effectiveness of the insulation.

Based on area-weighted averaging, ceiling insulation may be tapered near the eave, but it must be applied at a rate to cover the entire ceiling at the specified level. An elevated truss is not required but may be desirable in some applications.

3.5.4 Wall Insulation

3.5.4.1 Mandatory Requirements §150.0(c)

2x4 inch wood-framed walls above grade. Shall have a U-factor not exceeding U-0.102. In a wood-framed wall, this requirement is met with at least R-13 insulation installed in the cavities between framing members.

2x6 inch or greater wood-framed walls above grade. Shall have a U-factor not exceeding 0.071. In a wood-framed wall, this requirement is met with at least R-20 insulation installed in the cavities between framing members.

Masonry walls above grade. Must be insulated to meet the prescriptive requirements in Table 150.1-A or Table 150.1-B for mass walls.

All other wall types above grade. Must meet a maximum U-factor of U-0.102.

Demising partitions and knee walls. Demising and knee walls must meet or exceed minimum insulation requirements listed above, depending on wall type.

Exceptions: There are several cases where the mandatory measures for wall insulation do not apply or apply in a special way. For best practice, the following should be implemented:

1. The mandatory measures apply to framed foundation walls of heated basements or heated crawl spaces that are located above grade, but not to the portion that is located below grade.
2. For additions to existing buildings, existing wood-framed walls that are not being altered and are already insulated to a U-factor of 0.110 or lower, or that have existing R-11 insulation need not comply with the mandatory R-13 wall insulation.
3. Rim joists between floors of a multistory building are deemed to comply with these mandatory measures if they have R-13 insulation installed on the inside of the rim joist and are properly installed between intersecting joist members.



Demising Partitions and Knee Walls

Demising partitions and knee walls are not required to meet the prescriptive package requirements. Demising partitions and knee walls shall meet the mandatory minimum wall insulation requirements from §150.0(c).

3.5.4.2 Prescriptive Requirements (Table 150.1-A)

1. Framed Walls

The prescriptive requirements in Table 150.1-A call for a U-factor of 0.048 for single-family homes and 0.051 for multifamily buildings in Climate Zones 1-5 and 8-16, and a U-factor of 0.065 in Climate Zones 6 and 7 for both building types.

The designer may choose any wall construction from Reference Joint Appendix JA4 (Tables 4.3.1 and 4.3.4) that has a U-factor equal to or less than 0.048 or 0.065, depending on the climate zone.

Wood Frame. JA4 Table 4.3.4 shows that a 2x6 wood-framed wall at 16-inches-on-center can achieve a U-factor of 0.048 with R-21 batt insulation in the cavity and R-5 exterior insulation.

Some examples of various wood-framed wall assemblies, associated construction, and U-values are provided in Table 3-10.

Figure 28: Wood-Framed Wall With Brick Veneer

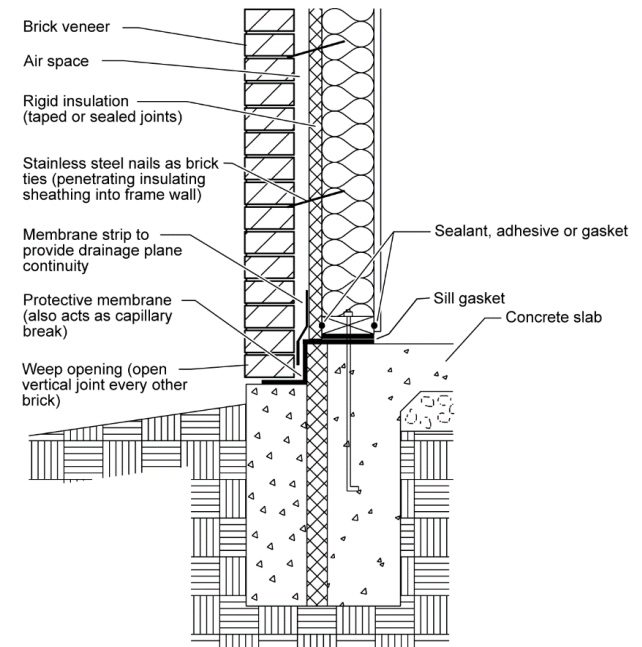

Source: California Energy Commission

Table 3-10: Examples of Wood-Framed Wall Assemblies and U-Factors, Assuming Gypsum Board Interior

Stud (16" oc)	Cavity Insulation	Cavity Insulation Type	Exterior Insulation	U-Factor
2x4	R15	High density batt	R4	0.065
2x4	R13	Open-cell spray foam (ocSPF)	R5	0.064
2x4	R15	High density batt	R8	0.050
2x6	R21	Loose-fill cellulose or high density batt	R4	0.051
2x6	R19	Low density batt	R5	0.051
2x6	R31	Closed-cell spray foam (ccSPF)	R2	0.049
2x6	R23	High density batt or mineral wool	R4	0.049
2x6	R21	Loose-fill cellulose or high density batt	R5	0.048
2x6	R19	Low density batt	R6	0.048
2x6	R23	High density bat or mineral wool	R5	0.047

Metal Frame. Metal-framed assemblies also will require rigid insulation to meet the maximum U-factor criteria. U-factors for metal-framed walls are given in Reference Joint Appendix JA4 Table 4.3.4 and can also be calculated using Energy Commission-approved compliance software.

Calculating U-factors. U-factors can also be calculated by building the construction assembly in Commission-approved compliance software, including the inside finish, sheathing, cavity insulation, and exterior finish. Find approved compliance software here:

http://www.energy.ca.gov/title24/2019standards/2019_computer_prog_list.html.

Example 3-24: Prescriptive or Performance Approach for My Wall Assembly?

Question: A new single-family house will have 2x6 framed walls with R-21 cavity insulation and R-5 continuous rigid insulation on the outside. Can this building comply with the Energy Standards using either the prescriptive or performance approach?

Answer: If the house has wood framing, the assembly U-factor would be U-0.048 as per JA4 Table 4.3.1. This U-factor prescriptively complies with the prescriptive U-factor requirements in all climate zones, and the building would not need to use the performance approach. If the house has metal framing, the assembly U-factor would be U-0.083 as per JA4 Table 4.3.4. This U-factor exceeds the maximum U-factor allowed in the prescriptive package and exceeds the mandatory maximum (U-0.071). The building would not comply regardless of the approach method used.

Example 3-25: Wall Assembly Not Found in Joint Appendix JA4

Question 1: For a new wall, if 2 inches of medium-density, closed-cell spray polyurethane foam (ccSPF) is used in combination with R-13 batt insulation in the cavity of a 2x6 wood framed wall with 16" on center spacing, without continuous insulation added, what is the total U-factor for the wall assembly?

Answer 1: Medium-density ccSPF is given a default value of R-5.8 per inch, as per JA4 Table 4.1.7. When 2 inches of ccSPF is added to R-13 batt insulation, the total cavity insulation is rounded to R-25. The assembly U-factor was calculated to be 0.065 using Commission-approved compliance software:

Question 2: Does this assembly meet prescriptive compliance requirements in Climate Zones 6 and 7?

Answer 2: Yes. The assembly does meet the minimum mandatory wall insulation U-factor requirement of 0.071, as well as the prescriptive U-factor requirement of 0.065 in Climate Zones 6 and 7.

Question 3: How about in other climate zones?

Answer 3: No. The assembly does not meet the prescriptive compliance U-factor requirement of 0.048 in Climate Zones 1-5 and 8-16 for single-family homes or 0.051 for multifamily buildings. To meet the prescriptive requirement for those climate zones, other wall assemblies may be used, and/or advanced wall system (AWS) techniques may be used to reduce the framing factor. Alternatively, the project may be shown to comply with the Energy Standards using the performance approach. For more on the performance approach, see Section 3.6

The screenshot shows the 'Construction Data' form in the CBECC-Res software. The 'Currently Active Construction' is 'Exterior Wall Cons'. The 'Construction Name' is 'Exterior Wall Cons', 'Can Assign To' is 'Exterior Walls', and 'Construction Type' is 'Wood Framed Wall'. The 'Construction Layers (inside to outside)' are divided into 'Cavity Path' and 'Frame Path'. The 'Cavity Path' includes 'Inside Finish: Gypsum Board', 'Sheathing / Insulation: - no sheathing/insul. -', 'Cavity / Frame: R 25', 'Sheathing / Insulation: - no sheathing/insul. -', and 'Exterior Finish: - select finish -'. The 'Frame Path' includes 'Inside Finish: Gypsum Board', 'Sheathing / Insulation: - no sheathing/insul. -', 'Cavity / Frame: 2x6 @ 16 in. O.C.', 'Sheathing / Insulation: - no sheathing/insul. -', and 'Exterior Finish: - select finish -'. There are checkboxes for 'Non-Standard Spray Foam in Cavity' and 'Specify Non-std Framing Factor', both of which are unchecked. At the bottom, the 'Winter Design U-value' is displayed as 0.065 Btu/h-ft2-F, with a note that it meets the maximum code U-value of 0.065.

CBECC-Res Software Wall Assembly Construction showing U-0.065 Assembly

2. Mass Walls

Location of Insulation. The prescriptive requirements have separate criteria for mass walls with interior insulation and mass walls with exterior insulation. “Interior” denotes that insulation is installed on the interior surface of the mass wall, and “exterior” denotes that insulation is installed on the exterior surface of the mass wall.

Mass walls with insulation applied in locations other than directly to the interior or exterior, such as concrete sandwich panels, must meet the requirements for mass walls with exterior insulation. Mass walls with insulation applied to both the interior and exterior, such as insulated concrete forms (ICF), must meet the requirements for mass walls with interior insulation. Placement of insulation on mass walls will affect the thermal mass properties of a building. When the prescriptive compliance approach is used, the continuous insulation must be installed integral with or on the exterior or interior of the mass wall.

Calculating the U-Factor. To calculate the effective U-factor of a furred wall using the tables in Reference Joint Appendix JA4:

1. Select a U-factor from JA4 Table 4.3.5 (Hollow Unit Masonry) or 4.3.6 (Solid Unit Masonry or Concrete) consistent with the type of wall.
2. Select the appropriate effective R-value for interior or exterior insulation layers from JA4 Table 4.3.14.
3. Use Equation 4-1, and the values selected, to calculate the U-factor of the construction assembly with the continuous insulation.
4. Compare the U-factor; it must be equal to or greater than the mass prescriptive U-factor from Energy Standards Table 150.1-A or Table 150.1-B to comply.



The U-factor of furred concrete or masonry walls also can be determined by building the construction assembly in Commission-approved compliance software.

Compliance and Enforcement for Insulation Installation in Framed Assemblies.

Documentation of insulation R-values and assembly U-factors includes product data sheets, manufacturer specifications and installation guidelines, insulation product and assembly testing information, and U-factor calculations following the procedures specified in JA4 or from results of approved performance compliance computer software.

The plans examiner should verify that the insulation R-value for walls (cavity and/or continuous) on the CF1R document is specified on the building plans and compliant with Table 150.1-A or Table 150.1-B.

The building inspector should verify the installed wall insulation meets or exceeds the R-value on the CF1R document.

Batt and loose fill insulation should fill the wall cavity evenly. If kraft or foil-faced insulation is used, it should be installed per manufacturer recommendations to minimize air leakage and avoid sagging of the insulation.

Wall insulation should extend into the perimeter floor joist (rim joist) cavities along the same plane as the wall. If a vapor retarder is required, it must be installed on the conditioned space side of the framing.

Figure 3-29: Masonry Wall With Furring Details



Source: California Energy Commission



Because it is difficult to inspect wall insulation behind tub and shower enclosures after the enclosures are installed, insulation of these wall sections should be inspected during the framing inspection.

Example 3-26: Minimum Insulation for Block Walls

Question: Do new residential buildings or additions consisting of block walls (for example, converting a garage into living space) have to comply with the R-13 minimum wall insulation requirement? If not, what insulation R-value do they need?

Answer: Block walls are considered masonry walls, and according to §150.0(c)3, the wall must have a U-factor not exceeding that required in Tables 150.1-A or Table 150.1-B.

3.5.5 Raised-Floor Insulation §150.0(d)

3.5.5.1 Mandatory Requirements

Wood-framed floors over unconditioned space, regardless of whether there is a crawlspace, must have at least R-19 insulation installed between framing members, or the construction must have a U-factor of 0.037 or less. The equivalent U-factor is based on R-19 insulation in a 2x6, 16 inch on center wood-framed floor with a crawl space.

Other types of raised floors, except for concrete raised floors (concrete raised floors do not have a mandatory requirement, but do have a prescriptive requirement) must also meet the maximum U-factor. In all cases, some areas of the floor can have a U-factor greater than the requirement as long as other areas have a U-factor that is lower than the requirement and the area-weighted average U-factor is less than that described above.

Raised slab floors with radiant heat (heated slab floors) must meet special insulation requirements that are described in Chapter 4 of this manual.



When a controlled ventilated or an unvented crawlspace is used, raised-floor insulation is not required, although a vapor retarder is required over the ground, and the foundation walls must be insulated.

3.5.5.2 Prescriptive Requirements

The prescriptive requirements differ for concrete raised floors and wood-framed floors. While the requirements for framed floors are the same in all climate zones, the requirements for concrete raised floors differ.

Framed Raised Floors. Table 150.1-A or Table 150.1-B (prescriptive requirements) call for a minimum of R-19 insulation installed between wood framing or a maximum area-weighted average U-factor of 0.037 for framed raised floors in all climate zones. The requirement may be satisfied by installing the specified amount of insulation in a wood-framed floor or by meeting an equivalent U-factor. U-factors for raised floor assemblies are listed in Reference Joint Appendix JA4.4.

Table 3-11: Wood-Framed Raised Floor Constructions Meeting Prescriptive Requirements

Insulation R-Value	Crawlspace?	Reference Joint Appendix JA4 Construction and Table Cell Entry	Equivalent U-Factor
R-19	No	4.4.2 A4	0.049
R-19	Yes	4.4.1 A4	0.037

Concrete Raised Floors. Concrete floors separating multifamily habitable space from a parking garage are also considered a raised floor. Insulation requirements for concrete raised floors differ by climate zone, summarized in Table 3-12.

Table 3-12: Insulation Requirements for Concrete Raised Floors per Table 150.1-A

Climate Zone	1,2,11,13,14,16	12,15	3-10
U-Factor	≤ 0.092	≤ 0.138	≤ 0.269
R-Value of Continuous Insulation	≥ R-8	≥ R-4	No Req.

Installation. Floor insulation should be installed in direct contact with the subfloor so that there is no air space between the insulation and the floor. Support is needed to prevent the insulation from falling, sagging, or deteriorating. Options for support include netting stapled to the underside of floor joists, insulation hangers running perpendicular to the joists, or other suitable means. Insulation hangers should be spaced at 18 inches or less before rolling out the insulation. See Figure 3-30. Insulation hangers are heavy wires up to 48 inches long with pointed ends, which provide positive wood penetration. Netting or mesh should be nailed or stapled to the underside of the joists. Floor insulation should not cover foundation vents.

Figure 3-30: Raised Floor Insulation

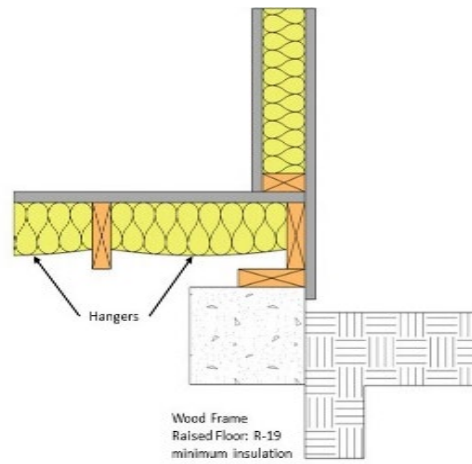

Source: California Energy Commission

3.5.6 Slab Insulation

3.5.6.1 Mandatory Requirements §150.0(f)

Slab Insulation Products

The mandatory requirements state that the insulation material must be suitable for the application. Insulation material in direct contact with soil, such as perimeter insulation, must have a water absorption rate no greater than 0.3 percent when tested in accordance with ASTM C272 Test Method A, 24-Hour Immersion, and a vapor permeance no greater than 2.0 perm/inch when tested in accordance with ASTM E96.

The insulation must be protected from physical and UV degradation by either installing a water-resistant protection board, extending sheet metal flashing below grade, choosing an insulation product that has a hard durable surface on one side, or by other suitable means.

The top of the insulation must be protected with a rigid material to prevent intrusion of insects into the building foundation.

A common location for the slab insulation is on the foundation perimeter (Figure 3-31). Insulation that extends downward to the top of the footing is acceptable. Otherwise, the insulation must extend downward from the level of the top of the slab, down 16 inches (40 cm) or to the frost line, whichever is greater.

Figure 3-31: Perimeter Slab Insulation

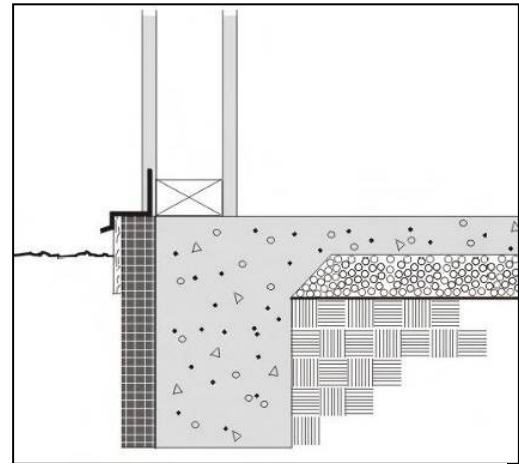

Source: California Energy Commission

For below-grade slabs, vertical insulation shall be extended from the top of the foundation wall to the bottom of the foundation (or the top of the footing) or to the frost line, whichever is greater.

Heated Slab Floor Insulation §110.8(g)

Heated slab-on-grade floors must be insulated according to the requirements in Table 110.8-A and Table 3-13.

One option is to install the insulation between the heated slab and foundation wall. In this case, insulation must extend downward to the top of the footing and then extend horizontally inward four feet toward the center of the slab. R-5 vertical insulation is required in all climates except Climate Zone 16, which requires R-10 of vertical insulation and R-7 horizontal insulation.



Table 3-13: Slab Insulation Requirements for Heated Slab Floors

Insulation Location	Insulation Orientation	Installation Requirements	Climate Zone	Insulation R-Value
Outside edge of heated slab, either inside or outside the foundation wall	Vertical	From the level of the top of the slab, down 16 inches or to the frost line, whichever is greater. Insulation may stop at the top of the footing, where this is less than the required depth. For below-grade slabs, vertical insulation shall be extended from the top of the foundation wall to the bottom of the foundation (or the top of the footing) or to the frost line, whichever is greater.	1 – 15	5
			16	10
Between heated slab and outside foundation wall	Vertical and Horizontal	Vertical insulation from top of slab at inside edge of outside wall down to the top of the horizontal insulation. Horizontal insulation from the outside edge of the vertical insulation extending 4 feet toward the center of the slab in a direction normal to the outside of the building in plain view.	1 – 15	5
			16	10 vertical and 7 horizontal

3.5.6.2 Prescriptive Requirements

Tables 150.1-A and 150.1-B of the Energy Standards require slab insulation only in Climate Zone 16 for unheated slabs. All heated slabs must meet mandatory insulation requirements in §110.8(g).

For unheated slabs in Climate Zone 16, a minimum of R-7 slab-edge insulation or a maximum U-factor of 0.58 must be achieved. The insulation must be installed to a minimum depth of 16 inches or to the bottom of the footing, whichever is less. The depth is measured from the top of the insulation, as near the top of slab as practical, to the bottom edge of the insulation. See Figure 3-32.

Figure 3-32: Allowed Slab Edge Insulation Placement

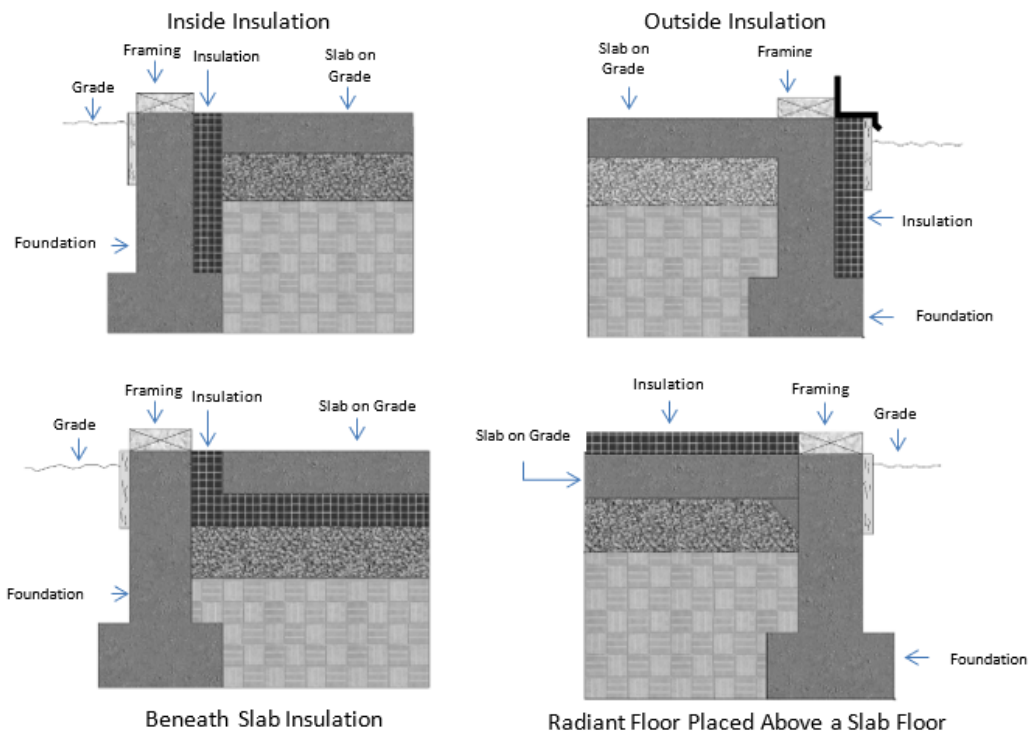

Source: California Energy Commission



Perimeter insulation is not required along the slab edge between conditioned space and the concrete slab of an attached unconditioned enclosed space such as a garage, covered porch, or covered patio. Neither would it be practical or necessary to insulate concrete steps attached to the outside slab edge.

Example 3-27: Heated Slab Insulation

Question: What are the slab edge insulation requirements for a hydronic-heating system with the hot water pipes in the slab?

Answer: The requirements for insulation of heated slabs can be found in §110.8(g) of the Energy Standards and are described in Section 3.5.6.1 of this manual. The material and installation specifications are as follows:

1. Insulation values as shown in Table 110.8-A of the Energy Standards
2. Protection from physical damage and UV light deterioration
3. Water absorption rate no greater than 0.3 percent (ASTM C272)
4. Water vapor permeance no greater than 2.0 perm/inch (ASTM E96)

3.5.7 Thermal Mass

Thermal mass consists of exposed tile floors over concrete, mass walls such as stone or brick, and other heavy elements within the building envelope that stabilizes indoor temperatures. Thermal mass helps temper interior temperature, storing heat or cooling for later use. In California's Central Valley and desert climates, the summer temperature range between night and day can be 30°F or more, and thermal mass can be an effective strategy to reduce daytime cooling loads.

Mass walls typically fall into two categories:

- **Masonry.** Masonry includes clay and concrete units, which may be solid or hollow, and glazed or unglazed. Other masonry unit types include cast stone and calcium silicate units. Concrete masonry units (CMU) are made from a mixture of Portland cement and aggregates under controlled conditions. Concrete masonry units can be manufactured in different sizes and with a variety of face textures.
- **Concrete and concrete sandwich panels.** Concrete and concrete sandwich panels typically use a precast form by casting concrete in a reusable mold or "form" that is then cured in a controlled environment, transported to the construction site, and lifted into place. Precast stone is distinguished from precast concrete by using a fine aggregate in the mixture, giving the appearance of naturally occurring rock or stone.

When thermal mass exists in exterior walls, it stabilizes temperatures in two ways. First, there is a time delay between when the outside temperature of the wall reaches its peak and when the inside of the wall reaches its peak. For an 8-inch to 12-inch concrete wall, this time delay is between 6 to 10 hours. Second, there is a dampening effect whereby the temperature range inside the house is less than the temperature range outside the house. These effects are illustrated in the Figure 3-33.

Figure 3-33: Thermal Mass Performance

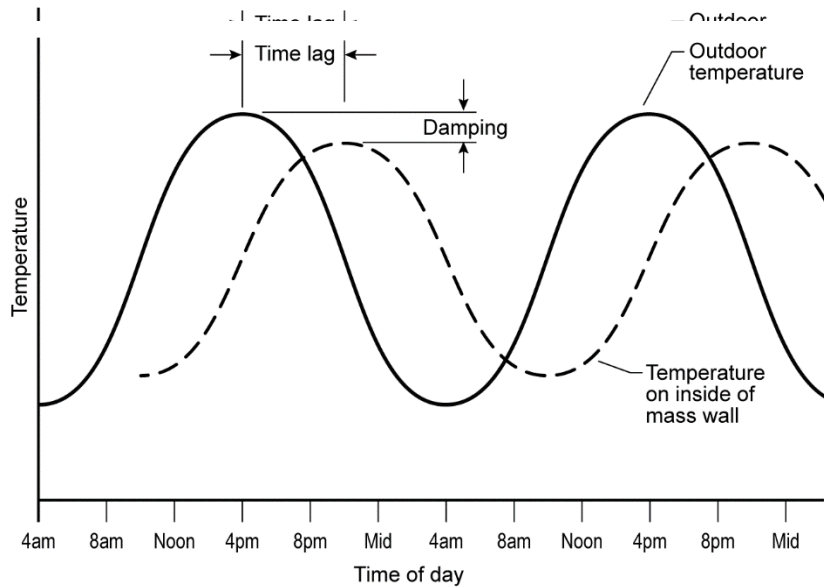

Source: California Energy Commission



When the performance method is used, credit is offered for increasing thermal mass in buildings. This procedure is automated in Energy Commission-approved computer compliance software. See Section 3.6 for the performance method.

3.5.8 Quality Insulation Installation (QII) RA 3.5

Prescriptive Requirements (Table 150.1-A and Table 150.1-B)

The prescriptive requirements shown in Table 150.1-A and Table 150.1-B call for QII in all climate zones for new construction and additions greater than 700 square feet, except low-rise multifamily buildings in Climate Zone 7.

All insulation shall be installed properly throughout the building. A third-party HERS Rater is required to verify the integrity of the installed insulation. The installer shall provide evidence to the HERS Rater using compliance documentation that all insulation specified is installed to meet specified R-values and assembly U-factors.

To meet QII, two primary installation criteria must be adhered to and they both must be field-verified by a HERS Rater. They include air sealing of the building enclosure (including walls, ceiling/roof, and floors), as well as proper installation of insulation. Refer to Reference Appendices RA3.5 for more details.

Many residential insulation installations have flaws that degrade thermal performance. Four problems are generally responsible for this degradation:

1. There is an inadequate air barrier in the building envelope or holes and gaps within the air barrier system that inhibit the ability to limit air leakage.
2. Insulation is not in contact with the air barrier, creating air spaces that short-circuit the thermal break of the insulation when the air barrier is not limiting air leakage properly.
3. The insulation has voids or gaps, resulting in portions of the construction assembly that are not properly insulated and, therefore, have less thermal resistance than other portions of the assembly (Figure 3-34).
4. The insulation is compressed, creating a gap near the air barrier and/or reducing the thickness of the insulation.

Figure 3-34: Examples of Poor Quality Insulation Installation

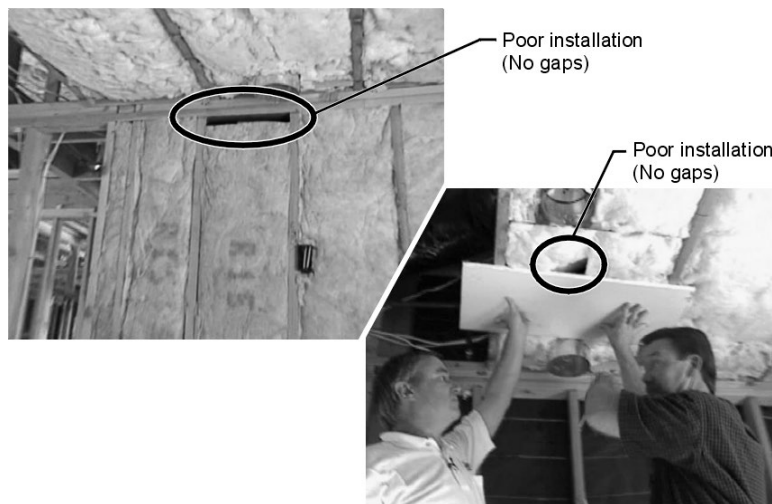

Source: California Energy Commission

QII requires third-party HERS inspection to verify that an air barrier and insulation are installed correctly to eliminate or reduce common problems associated with poor installation. Guidance for QII is provided in Residential Appendix RA3.5. QII applies to framed and nonframed assemblies. Residential construction may incorporate multiple frame types, for example, using a combination of nonframed walls with a framed roof/ceiling. Likewise, multiple insulation materials often are used.

Framed Assemblies

Framed assemblies include wood and steel construction insulated with batts of mineral fiber, mineral and natural wool, or cellulose; loose-fill insulation of mineral fiber, mineral and natural wool, cellulose, or spray polyurethane foam (SPF). Rigid board insulation may be used on the exterior or interior of framed or nonframed assemblies.

Nonframed Assemblies

Nonframed assemblies include structural insulated panels (SIP), insulated concrete forms (ICF), and mass walls of masonry, concrete and concrete sandwich panels, log walls, and straw bale.



Tips for Implementing QII

Applies to all Insulation	QII applies to the whole building - roof/ceilings, walls, and floors - and requires field verification by a third-party HERS Rater.
Slab Edge Insulation	If slab edge insulation is installed, then the integrity of the slab edge insulation must also be field-verified in addition to the air barrier and insulation system for walls and the roof/ceiling.
Various Insulation Types	Combinations of insulation types (hybrid systems) are allowed.
Air Barriers	An air barrier shall be installed for the entire envelope.
Additions	QII is prescriptively required for additions to existing buildings more than 700 square feet. Refer to Chapter 9 for additional information specific to additions.
Alterations	Compliance credit is allowed for alterations to existing buildings where the “existing, plus addition, plus alteration” approach is used, but credit will only apply to new surfaces in the new zone.
Insulated Headers	<p>Headers shall meet one of the following criteria for QII:</p> <ul style="list-style-type: none"> a. Two-member header with insulation in between. The header and insulation must fill the wall cavity. There are prefabricated products available that meet this assembly. Example: a 2x4 wall with two 2x nominal headers, or a 2x6 wall with a 4x nominal header and a 2x nominal header. Insulation is required to fill the wall cavity and must be installed between the headers. b. Two-member header, less than the wall width, with insulation on the interior face. The header and insulation must fill the wall cavity. Example: a 2x6 wall with two 2x nominal headers. Insulation is required to fill the wall cavity and must be installed to the interior face of the wall. c. Single-member header, less than the wall width, with insulation on the interior face. The header and insulation must fill the wall cavity. Example: a 2x4 wall with a 3-1/8-inch-wide header, or 2x6 wall with a 4x nominal header. Insulation is

	<p>required to fill the wall cavity and must be installed to the interior face of the wall.</p> <p>d. Single-member header, same width as wall. The header must fill the wall cavity. Example: a 2x4 wall with a 4x nominal header or a 2x6 wall with a 6x nominal header. No additional insulation is required because the header fills the cavity.</p>
Panel Box Headers	<p>Wood structural panel box headers may also be used as load-bearing headers in exterior wall construction, when built in accordance with 2015 CRC Figure R602.7.3 and Table R602.7.3.</p>
Structural Bracing, Tie-Downs, Steel Structural Framing	<p>Metal bracing, tie-downs, or steel structural framing can be used to connect to wood framing for structural or seismic purposes, and comply with QII if:</p> <ul style="list-style-type: none"> a. Metal bracing, tie-downs, or steel structural framing is identified on the structural plans. b. Insulation is installed in a manner that minimizes the thermal bridging through the structural framing assembly. c. Insulation fills the entire cavity and/or adheres to all six sides and ends of structural assemblies that separate conditioned from unconditioned space. d. The structural portions of assemblies are airtight.

QII in the Compliance Modeling Software. QII is not a mandatory requirement; therefore, when using the performance approach, QII may be traded off with other efficiency measures. The compliance modeling software assumes QII and full insulation effectiveness in the standard design. The compliance modeling software automatically reduces the effectiveness of insulation for the proposed design in projects that do not pursue QII. The effect of a poorly installed air barrier system and envelope insulation results in higher wall heat loss and heat gain than standard R-value and U-factor calculations would indicate. Similar increases in heat loss and heat gain are experienced for roof/ceilings where construction and installation flaws are present. The reduction in effectiveness reflects standard industry installation practices and allows for full insulation credit to be taken for HERS verified quality insulation installation.

3.5.8.1 Air Barrier RA3.5.2

An air barrier shall be installed enclosing the entire building. The air barrier must be installed in a continuous manner across all components of framed and nonframed envelope assemblies. The installer shall provide evidence with compliance documentation that the air barrier system meets one or more of the air barrier requirements. More detailed explanation is provided in RA3.5. Documentation for the

air barrier includes product data sheets and manufacturer specifications and installation guidelines.



For QII, a third-party HERS Rater is required to verify that the air barrier has been installed properly and is integral with the insulation being used throughout the building.



Continuous Air Barrier Requirements

A combination of interconnected materials and assemblies are joined and sealed together to provide a continuous barrier to air leakage through the building envelope separating conditioned from unconditioned space, or adjoining conditioned spaces of different occupancies or uses. An air barrier must meet one of the following:

1. Using materials that have an air permeance not exceeding 0.004 cfm/ft² under a pressure differential of 0.3 in. w.g. (1.57 psf) (0.02 L/s.m² at 75 pa) when tested in accordance with ASTM E2178.
2. Using assemblies of materials and components that have an average air leakage not to exceed 0.04 cfm/ft² under a pressure differential of 0.3 in. w.g. (1.57 psf) (0.2 L/s.m² at 75 pa) when tested in accordance with ASTM E2357, ASTM E1677, ASTM E1680 or ASTM E283.
3. Testing the completed building and demonstrating that the air leakage rate of the building envelope does not exceed 0.40 cfm/ft² at a pressure differential of 0.3 in w.g. (1.57 psf) (2.0 L/s.m² at 75 pa) in accordance with ASTM E779 or an equivalent approved method.

The following materials meet the air permeance testing performance levels of 1 above. Manufacturers of these and other product types must provide a specification or product data sheet showing compliance to the ASTM testing requirements to be considered as an air barrier.

- Plywood – minimum 3/8 inch
- Oriented strand board – minimum 3/8 inches
- Extruded polystyrene insulation board – minimum 1/2 inch
- Foil-backed polyisocyanurate insulation board – minimum 1/2 inch
- Foil-backed urethane foam insulation – 1 inch
- Closed-cell spray polyurethane foam (ccSPF) with a minimum density of 2.0 pcf and a minimum thickness of 2.0 inches. Alternatively, ccSPF insulation shall be installed at a thickness that meets an air permeance no

greater than 0.02 L/s-m² at 75 Pa pressure differential when tested in accordance to ASTM E2178 or ASTM E283.

- Open cell spray polyurethane (ocSPF) foam with a minimum density of 0.4 to 1.5 pcf and a minimum thickness of 5½ inches. Alternatively, ocSPF insulation shall be installed at a thickness that meets an air permeance no greater than 0.02 L/s-m² at 75 Pa pressure differential when tested in accordance to ASTM E2178 or ASTM E283.
- Exterior or interior gypsum board – minimum 1/2 inch
- Cement board – minimum 1/2 inch
- Built-up roofing membrane
- Modified bituminous roof membrane
- Particleboard – minimum 1/2 inch
- Fully adhered single-ply roof membrane
- Portland cement/sand parge, or gypsum plaster – minimum 5/8 inch
- Cast-in-place and precast concrete
- Fully grouted uninsulated and insulated concrete block masonry
- Sheet steel or aluminum

Materials and assemblies of materials that can demonstrate compliance with the air barrier testing requirements must be installed according to the manufacturer's instructions, and a HERS Rater shall verify the integrity of the installation.

3.6 Opaque Envelope in the Performance Approach

Some residential projects may not wish to use or do not meet the requirements for prescriptive compliance. The performance approach offers increased flexibility as well as compliance credits for certain assemblies, usually those requiring HERS verification. The designs described below are examples of residential envelope strategies that can be implemented under the performance approach. The proposed design used under the performance approach is compared to the standard design, which is determined by the prescriptive requirements. Remember that when using the performance approach, all applicable mandatory measures must still be met.

Advanced Assemblies. Common strategies for exceeding the minimum energy performance level set by the 2019 Energy Standards include the use of better components such as:

- Higher insulation levels.
- More efficient fenestration.
- Reducing building infiltration.
- Use of cool roof products.

- Better framing techniques (such as the use of raised-heel trusses that accommodate more insulation).
- Reduced thermal bridging across framing members.
- Greater use of nonframed assemblies or panelized systems (such as SIPs and ICFs).
- More efficient heating, cooling, and water-heating equipment.

The performance approach encourages the use of energy-saving techniques for showing compliance with the Energy Standards.

Advanced Building Design. The design of a building, floor plan, and site design layout all affect energy use. A passive solar building uses elements of the building to heat and cool itself, in contrast to relying on mechanical systems to provide the thermal energy needs of the building. Passive solar strategies encompass several advanced high-performance envelope techniques, such as:

1. Carefully choosing the size, type, and placement of fenestration and shading.
2. Providing and controlling fresh air ventilation during the day and night.
3. Having internal and external thermal mass components that help store useful heat and cooling energy.
4. Having highly insulated envelope assemblies.
5. Using high performing roofing materials (cool roofs) and radiant barriers.
6. Having very low air leakage.

Some measures designed as part of an advanced assembly system may require specific installation procedures or field verification and diagnostic testing to ensure proper performance. Field verification and diagnostic testing are ways to ensure that the energy efficiency features used in compliance calculations are realized as energy benefits to the occupants.

3.6.1 Unvented Attics

Attic ventilation is the traditional way of controlling temperature and moisture in an attic. In an unvented attic assembly, insulation is applied directly at the roofline of the building, either above or below the structural roof rafter. The roof system becomes part of the insulated building enclosure. For this case, the thermal boundary of the building results in an unvented attic space between the ceiling gypsum board (gypboard) and the insulated roof above (Figure 3-35).

In addition to meeting the mandatory minimum insulation requirements, the provisions of CBC, Title 24, Part 2.5, Section R806.5 must be met.

Check with the local building jurisdiction to determine its specific requirements for unvented attic conditions.

Combining this strategy with the additional design improvement of low air leakage for the rest of the building would achieve energy savings and compliance energy credit.

Furthermore, this design eliminates the need to seal or limit penetrations at the ceiling level, such as recessed cans, because the air and thermal boundary is now located at the roof deck.

Figure 3-35: Unvented Attic Assembly With Insulation at the Ceiling and Between the Roof Rafters

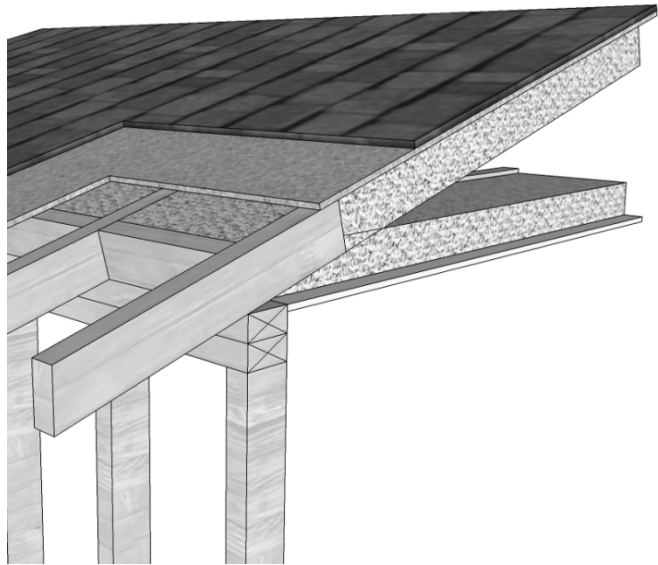

Source: California Energy Commission

Below-Deck Netted Insulation in Unvented Attics

Alternative types of insulation can provide high R-value insulation below the roof deck in an unvented attic. One approach is a boxed netted system that is suspended from the top member of the truss, or top chord, to provide a fill depth that completely encloses the top chord, creating a uniform insulation layer of loose-fill fiberglass across the entire underside of the roof deck. This method can be done with common loose-fill insulation tools and equipment. See Figure 3-36 for details of this type of below-deck netted insulation. Draped netted insulation, another approach to below-deck insulation, results in a nonuniform insulation layer, created by leaving the truss chords exposed and leading to increased thermal bridging (Figure 3-37).

Figure 3-36: Box Netted Insulation

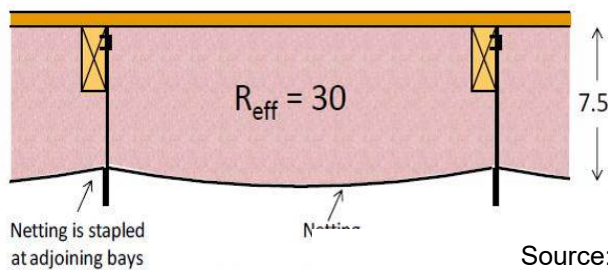
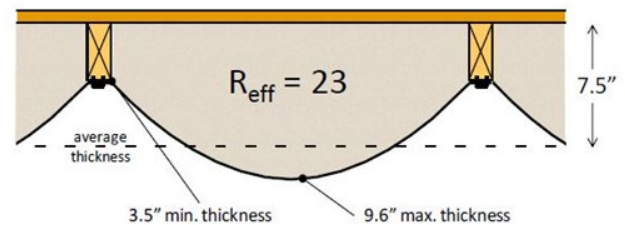

Figure 3-37: Draped Netted Insulation



Source: Owens Corning

Gable Ends in Unvented Attics

In unvented attics, where insulation is applied directly to the underside of the roof deck, framing for gable ends that separate the unvented attic from the exterior or unconditioned space shall be insulated to meet or exceed the wall R-value of the adjacent exterior wall

construction. The backside of air-permeable insulation exposed to the unconditioned attic space shall be completely covered with a continuous air barrier.

3.6.2 Above-Deck Insulation

Requires insulation above the roof rafters, directly in contact with the roof deck to add value to the thermal integrity of the roof system. Above-rafter insulation can be implemented with either asphalt shingles or clay/concrete tiles. The R-values for insulation installed above the roof rafters are lower than the R-values for insulation installed below the roof deck due to the added benefit of reduced thermal bridging when continuous insulation is applied to the roof deck. Further, when an air space is present between the roofing and the roof deck, the effect of insulation is greater than when there is no air space.

Figure 3-38: Detail of Above-Deck Insulation

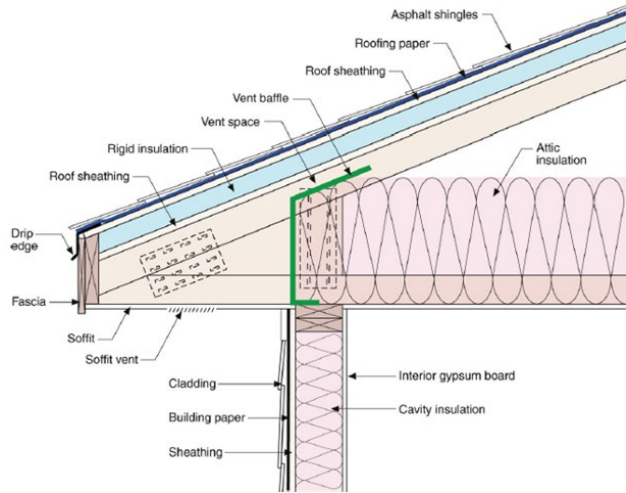

Source: Building Science Corporation



Check manufacturer’s specifications for proper nail schedules (fastening patterns); this will change depending on the roof pitch, truss spacing, and roofing material.

With concrete and clay tiles.

Standard construction practice in California for concrete and clay tiles is to have an air gap between the tiles and roof deck due to the shape of the tiles and the way tiles are installed over battens. When adding insulation above the roof deck, there are two options to addressing the air gap. If the air gap is desired, one option is to install rigid insulation over the roof deck and a second roof sheathing layer added above the rigid insulation. A vapor retarder would be

Figure 3-39: Battens (Purlins) Installed With Above-Deck Insulation

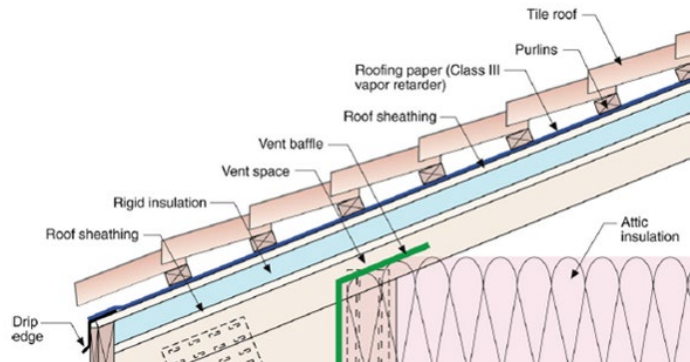

Source: Building Science Corporation

above the second sheathing layer to host the purlins with the tiles installed over them (Figure 3-39). If the air gap is not desired, there may be insulation products available that can fit directly under concrete/clay or steel tile.

With asphalt shingles. When installing asphalt shingles with roof deck insulation, it is best to implement a ventilation method between the roofing product and the top sheathing or insulation, as shown in Figure 3-40, to prevent the roofing material from experiencing high temperatures and reducing effective product life.

Figure 3-40: Above-Deck Insulation and Spacers Installed With and Without Top Sheathing

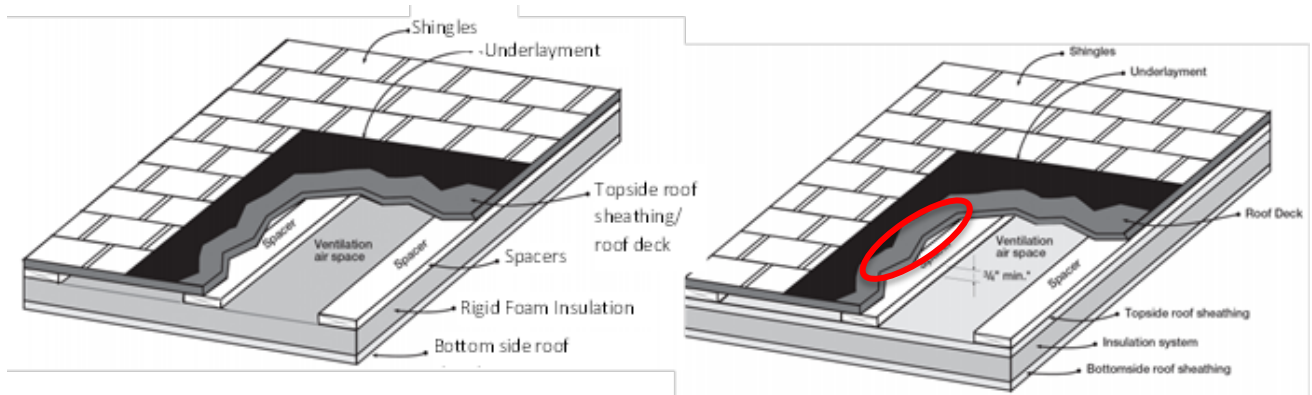

Source: ARMA technical bulletin No. 211-RR-94

Spacers can be inserted either above or below a second roof sheathing to provide roof deck ventilation and a nailable base for asphalt shingles (Figure 3-41). Manufacturers offer prefabricated insulation products with spacers and top sheathing. Check manufacturers’ and trade association websites for a list of products available that provide an air space and nailable base.

Figure 3-41: Asphalt Shingles and Spacers Installed With Above-Deck Insulation

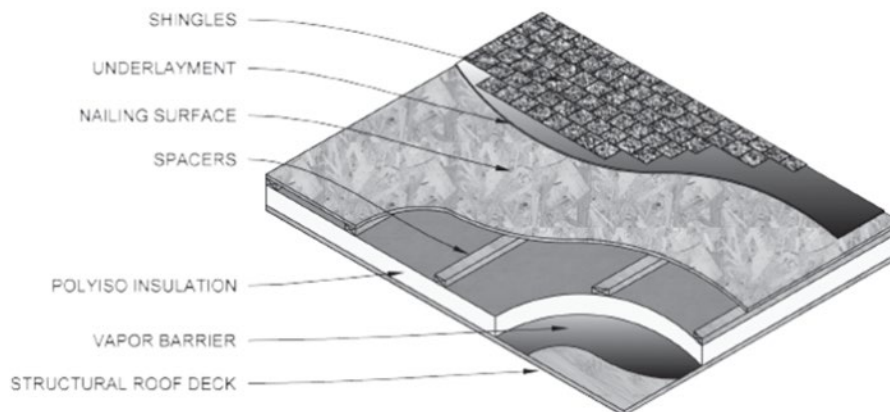

Source: PIMA Tech Bulletin #106

Example 3-28: Two Layers of Rigid Foam Board Above-Deck

Question: Can two layers of R4 rigid foam board be installed as an equivalent performance to R8 rigid foam insulation above the roof deck? If so, are there best practices for installing the two layers of insulation?

Answer: Yes, installing two R4 rigid foam board layers is equivalent in performance to R8. To prevent water infiltration, it is best to stagger the horizontal and vertical joints of the two layers and take care to seal each joint properly.

Example 3-29: Roof Material Directly Over Rigid Insulation

Question: A project plans to install R6 rigid foam insulation above the roof deck with roofing material placed *directly* over the insulation. What are the best practices for installing the insulation?

Answer: Insulation can be installed directly on the roof deck with no air gap, but performance is improved if an air gap is installed between the rigid insulation and the roof deck. Using spacers or battens (purlins) are two strategies to create this air gap. Products exist that combine insulation, spacers, and additional sheathing for nailing asphalt shingles. Check with insulation manufacturers for available products.

Example 3-30: Fire Ratings Required by CBC, Chapter 15

Question: Does a roof assembly using above deck insulation meet Class A/B/C fire rating specifications, as determined by California Building Code (CBC), Chapter 15?

Answer: Application of above-deck insulation affects the fire rating classification of roof covering products. Roof covering products are rated to Class A/B/C based on the ASTM E108 (NFPA 256, UL790) test. Class A/B/C ratings are done with specific roof assemblies, and ratings are valid only when the installation is the same as the assembly as rated. Under current building code requirement, tile roof products installed directly over the roof deck or over purlins are automatically rated Class A. Chapter 15 in the California Building Code (and International Building Code Section 1505 for Fire Classification) specify that certain roofing materials are Class A without having to test to ASTM E108. These materials include slate, clay, concrete roof tile, an exposed concrete roof deck, and ferrous and copper shingles; however, asphalt shingles are not covered under this category.

Insulation products, on the other hand, are subject to a different fire test from roof-covering products. The California Building Code and International Building Code (Section 2603 for Foam Plastic Insulation) require foam plastic insulation to be tested to demonstrate a flame-spread index of not more than 75 and a smoke-developed index of not more than 450 according to ASTM E84 (UL723). The requirements apply to roof insulation products, including XPS/polyiso/polyurethane above-deck insulation and SPF below-deck insulation products.

To ensure that roof assemblies with insulation meet the proper fire rating classification, roof product manufacturers and insulation manufacturers must test and develop assemblies that meet the CBC testing specifications.

3.6.3 Insulated Roof Tiles

Insulated roof tile (IRT) is an option for improving the thermal performance of the roof assembly and lowering attic temperatures. IRT combines concrete or clay tiles with insulation as a packaged product (Figure 3-42). Most of the increase in R-value is due to the integration of insulation into the roofing product itself. Additional thermal performance can be gained by combining IRT with rigid foam insulation inserts (Figure 3-43). These tiles are lighter than typical roof tiles and have better thermal performance than traditional tiles due to the insulating core.

IRT can reduce radiant losses and maintain warmer roof deck temperatures, thereby reducing the potential for condensation. Using one of the options below provides additional R-value when conventional ceiling insulation is installed.

All four configurations (A-D) in Figure 3-43 can be installed without any significant changes to conventional roof or attic design (such as changes to fascia dimensions). IRT can be used in vented and unvented attic configurations.

Some IRT products are ASTM-rated for Class A fire rating (ASTM E108) and have CRRC certification for cool roof tiles in multiple colors. Depending on the configuration selected from the four options (A-D) in Figure 3-43, a U-factor between 0.18 and 0.10 can be achieved, with Option D performing the best. It is best practice to check with manufacturers about the ratings and certifications for each tile. Product manufacturers cite several advantages of the product due to the lightweight construction and increased insulation properties – ease of installation, ability to install similar to traditional roof tiles but at a much faster pace, less weight on the roof structure, increased thermal resistance, and improved thermal performance.

Figure 3-42: Insulated Concrete Tile



Source: Green Hybrid Roofing

Figure 3-43: Insulated Roof Tile (IRT) (A) Attached Directly to Roof Deck, (B) Attached to Batten, (C) Attached Directly to Roof Deck With Wedged Foam Filling Air Space, and (D) Attached to Battens With Wedged Foam Filling Air Space

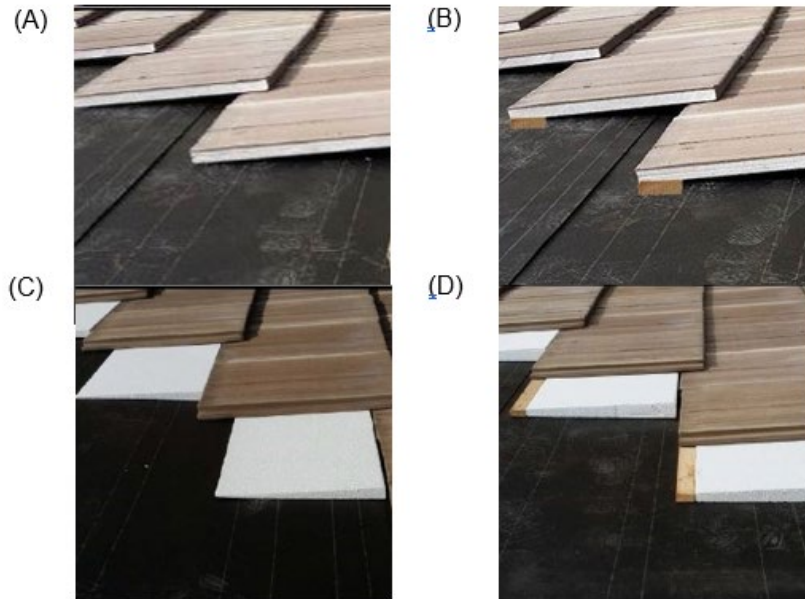

Source: Green Hybrid Roofing

3.6.4 Raised Heel, Extension Truss, or Energy Truss

The use of an energy truss, usually referred to as a raised heel or extension truss, allows full depth, uncompressed insulation at the ceiling to continue to the ceiling edge where the roof and ceiling meet. For this strategy, the roof truss is assembled with an additional vertical wood framed section at the point where the top and bottom truss chords meet. The vertical section raises the top chord and provides increased space that can be filled with insulation. See Figure 3-44 for details of a raised heel truss. Benefits of this strategy include:

- Realizing the full benefit of ceiling insulation.
- Providing more space for air handler and duct systems if located in the attic.

The 2019 CBECC-Res compliance software allows for the modeling of raised heel trusses and provides credit for the additional insulation at the edges.



Other construction methods to achieve a similar outcome include framing with a rafter on raised top plate or using spray foam or rigid foam at the edge.

Figure 3-44: Standard Truss vs. Raised Heel Energy Truss

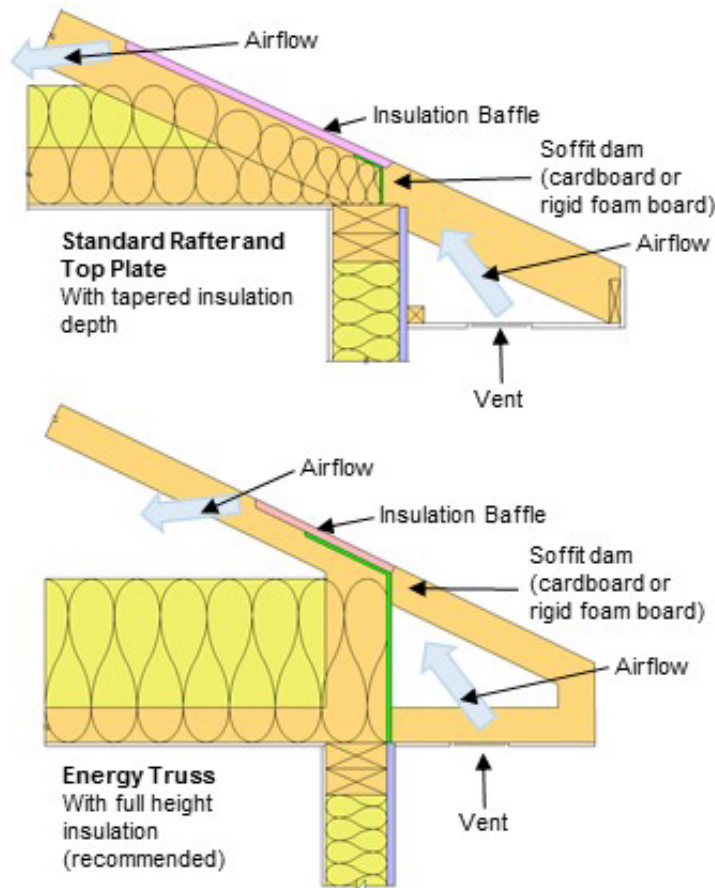

Source: California Energy Commission

3.6.5 Nail Base Insulation Panel

The nail base insulation panel is an above-roof rafter insulation strategy that consists of exterior-facing OSB or other structural sheathing laminated to continuous rigid insulation, which is fastened directly to roof framing (Figure 3-45). This saves the time and expense of installing a structural sheathing layer above and below the rigid insulation. The nail base insulation panel creates a nailing surface for attaching roof cladding.

Suitable for vented and unvented attic assemblies, the exposed underside of the rigid insulation has a facer that provides a radiant barrier, as well as

Figure 3-45: Nail Base Insulation Panel With Radiant Barrier Affixed to Trusses in a Vented Attic Configuration

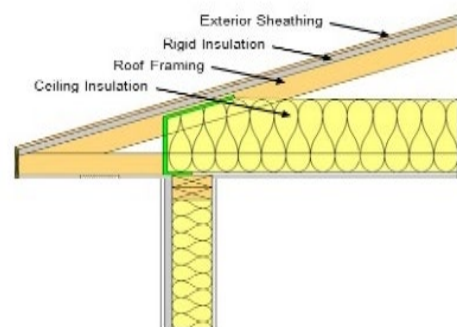

ignition/thermal barrier protection as required by code.

Source: California Energy
Commission

Example 3-31: Area-Weighted Averaging Insulation Levels

Question: A computer method analysis shows that a new house requires R-19 ceiling insulation to comply using the performance approach, but the minimum mandatory insulation level for ceiling insulation is R-22. Which insulation level should be used?

Answer: The mandatory minimum insulation requirement is an area-weighted average U-factor. Therefore, some areas can have lower insulation, such as R-19, but other areas will need to have higher levels of insulation so that the area-weighted average U-factor is at least 0.043.

Example 3-32: Minimum Insulation Levels When Using Performance Approach

Question: A small addition to an existing house appears to comply using only R-15 ceiling insulation with the performance approach. Does this insulation level comply with the standards?

Answer: No. R-15 would not be sufficient because the required minimum ceiling insulation level established by the mandatory measures is R-22. However, R-15 could be used in limited areas, as follows:

- a. Attic roofs must have a weighted average U-factor of 0.043 or less for the entire ceiling/roof.
 - b. Rafter roofs must have a weighted average U-factor of 0.054 or less for the entire ceiling/roof.
-

3.6.6 Advanced Wall Systems and Advanced Framing

Advanced wall systems (AWS), also known as optimum value engineering (OVE) or advanced framing, refer to a set of framing techniques and practices that minimize the amount of wood and labor necessary to build a structurally sound, safe, durable, and energy-efficient building. AWS improves energy and resource efficiency while reducing first costs.

Reducing the amount of wood in wood-framed exterior walls improves energy efficiency through a reduced framing factor, allowing more insulation to be installed, and has greater

resource efficiency for the materials being used. In addition, using fewer framing studs reduces the effects of “thermal bridging” and increases the amount of insulation in the wall, resulting in a more energy-efficient building envelope. The framing factor assumed for calculating the energy performance of a wood-framed 2x4 wall at 16” on center is 25 percent. When AWS is used, the framing factor is reduced to 17 percent, reflecting the improved energy performance of the advanced wall system.

Calculating Assembly U-Factors.

Figure 3-46 depicts one AWS that achieves a U-factor of 0.048 with an exterior insulation of R-4, due to 24” stud spacing and R-13 header assemblies.

Figure 3-46: Wood-Framed Wall, 2x6 @ 24” oc, AWF With Three-Stud corners

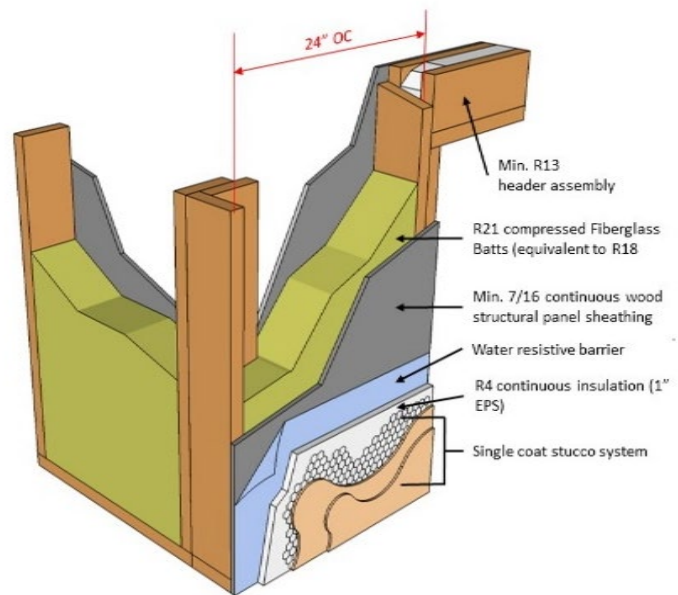

Source: California Energy Commission

Table 3-14 lists the assembly components for the AWS in Figure 3-46.

These values were calculated using the parallel heat flow calculation method, documented in the *2009 ASHRAE Handbook of Fundamentals* and outlined in Joint Appendices JA4.1.2 and JA4.6. The construction assembly in Table 4.6.1 in JA4.6 assumes an exterior air film of R-0.17, a 3/8-inch layer of stucco of R-0.08 (SC01), building paper of R-0.06 (BP01), sheathing, or continuous insulation layer, if present, the cavity insulation/framing layer, 1/2-inch gypsum board of R-0.45 (GP01), and an interior air film 0.68. The framing factor is assumed to be 25 percent for 16-inch stud spacing, 22 percent for 24-inch spacing, and 17 percent for advanced wall system (AWS). Actual cavity depth is 3.5 inches for 2x4, 5.5 inches for 2x6.

Table 3-14: Assembly Components for AWS in Figure 4-46

Layer	Assembly Type: Wall 2x6 @ 24" oc AWS	R-Value		
	Framing Material: Wood			
	Assembly Components	Cavity (R _c)	Frame (R _f)	Header (R _h)
0	Frame Factor	78%	17%	5%
1	Outside Air Film	0.17	0.17	0.17
2	Building Paper	0.06	0.06	0.06
3	3/8-Inch Single Coat Stucco	0.08	0.08	0.08
4	R4 Continuous Insulation (1" EPS)	4	4	4
5	7/16-Inch Continuous Oriented Strand Board Sheathing (OSB)	0.44	0.44	0.44
6	R-20 Fiberglass Batts	20.0	--	--
7	Header Assembly – 2x Wood			1.485
8	Header Assembly – 2.5 Inches of R4 Foam			10
9	Header Assembly – 2x Wood			1.485
10	2x6 Framing @ R-0.99/Inch	--	5.445	--
11	½-Inch Gypboard	0.45	0.45	0.45
12	Inside Air Film	0.68	0.68	0.68
	Subtotal R-Values	25.88	11.325	18.85
	U-Factors (Frame % x 1/R)	0.0301	0.0150	0.0027
	Assembly U-Factor $(U_{\text{Cavity}} + U_{\text{Frame}} + U_{\text{Header}})$	Assembly U-Factor	0.048	



While AWS represents a range of practices, it must be adequately inspected to ensure framing contractors have adhered to all best practice construction techniques throughout the exterior envelope.

Examples of construction practices for AWS that can be used as a general guide for building inspectors:

1. Use a minimum 2x6 at 24" on-center wall framing.
2. Use precise engineering of headers on load-bearing walls.
3. Install 2x4, 2x6, or I-joist headers on exterior non-load-bearing walls.
4. Eliminate cripple studs at window and door openings less than 4 feet wide.
5. Align window/door openings with standard stud spacing.
6. The king stud, on at least one side of the window/door opening, must take the place of an on-layout AWS stud.
7. Use an insulated corner, either a two-stud corner or a California (three-stud) corners, as in the examples provided in Figure 3-47.
8. Nailing for interior gypsum board can be accomplished with drywall clips, 1x nailer strip, recycled plastic nailing strip. Drywall clips reduce the potential for drywall cracking.
9. Use ladder block where interior partitions intersect exterior walls, instead of three-stud channels.
10. Eliminate unnecessary double-floor joists underneath nonbearing walls.
11. Use metal let-in T-bracing or other methods on nonshear walls to allow full insulation.
12. Include detailed framing plans and elevations on the construction permit plan set.
13. Optimize house design for efficient material use (for example, reducing header spans, designing exterior surfaces in 2-foot modules, designing clear spans to eliminate interior bearing walls).
14. Build with "insulated headers." An example of a single-ply insulated header is provided in Figure 3-48. See Reference Appendices RA3.5 for more information.
15. Use engineered lumber. Examples include "I"-joists, open web floor trusses, 2x raised heel roof trusses, glulam beams, laminated veneer lumber (LVL), laminated strand lumber (LSL), parallel strand lumber (PSL), oriented strand board (OSB).
16. Eliminate trimmers at window and door opening headers less than 4 feet wide, only when rated hangers are used and noted on the plans.
17. Use 2x4 or 2x3 interior nonload-bearing walls.
18. Integrate framing design with HVAC system.
19. Use "inset" shear wall panels.

Figure 3-47: Advanced Framing Corners

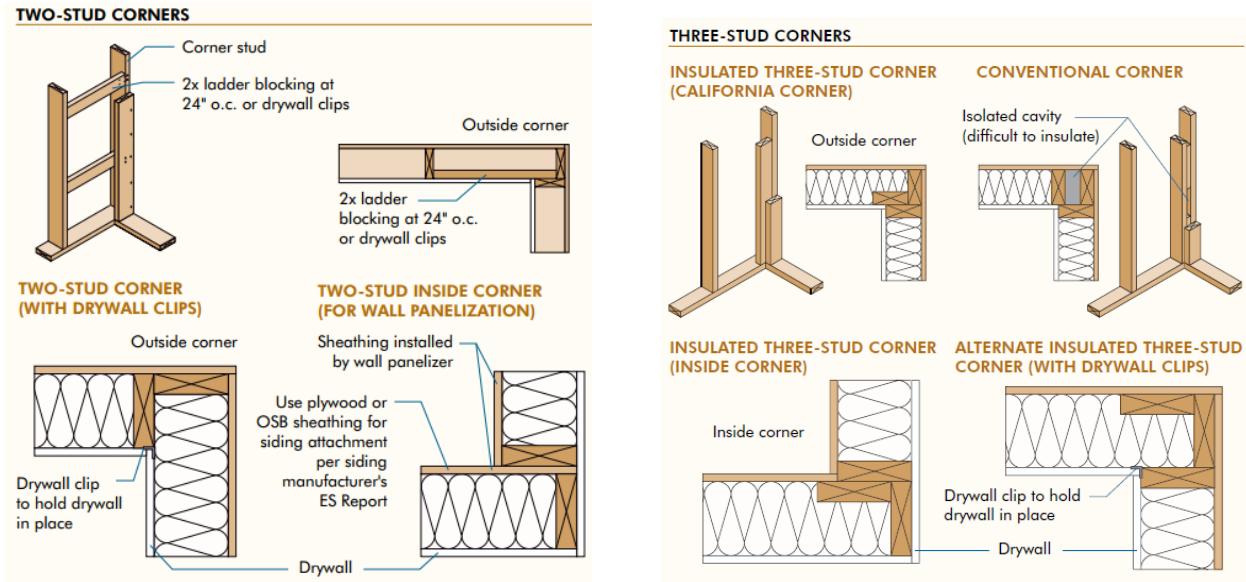

Source: APA Advanced Framing Guide

Figure 3-48: Headers Designs With Cavity Insulation Space

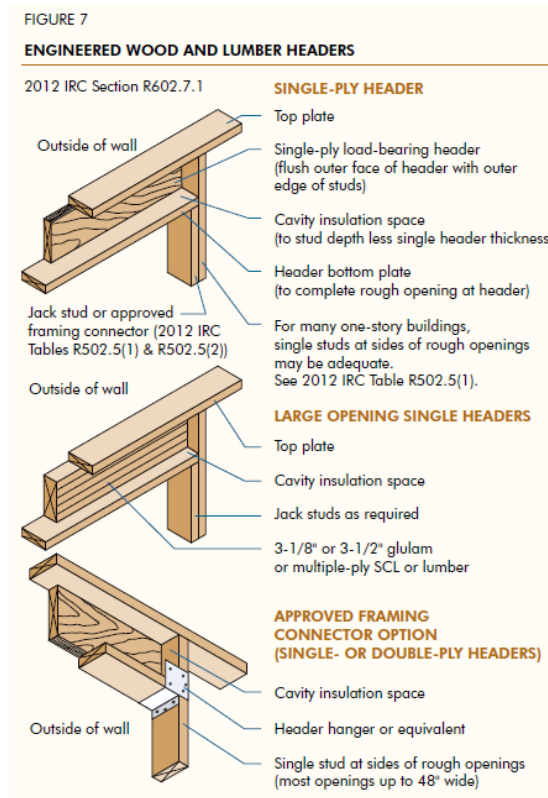

Source: APA Advanced Framing Guide

Double and Staggered Wall Assemblies. Double-wall and staggered-wall systems were developed to better accommodate electrical and plumbing systems, allow higher levels of insulation, and provide greater sound reduction. The advantages of these types of wall systems are the following:

1. Smaller dimensional lumber can be used.
2. It is easier to install insulation properly.
3. It eliminates thermal bridging through the framing.
4. It reduces sound transmission through the wall.

With double walls, insulation may be on one side of the wall or on both (higher R-values). It is not uncommon to find double walls with insulation installed within the outside wall cavities, leaving the inside wall sections open for wiring and plumbing (Figure 3-49).

With staggered walls, thermal batt insulation may be installed horizontally or vertically, butting the sides of the insulation until the cavity across the entire wall section is completely filled.

Figure 3-49: Typical Double and Staggered Wall Systems

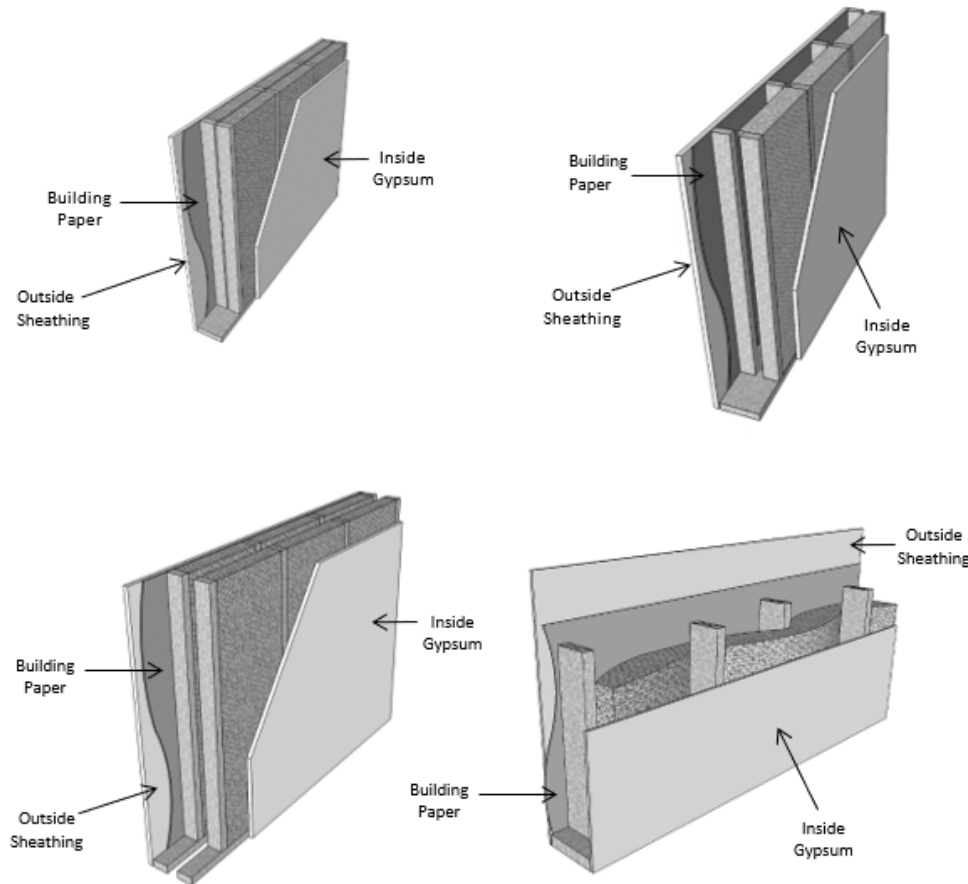

Source: California Energy Commission

3.6.7 Metal Framing

A change from wood framing to metal framing can significantly affect compliance. Metal-framed assemblies are often chosen where greater structural integrity is necessary or in climate conditions where greater durability is necessary to protect from the effects of excessive moisture exposure. Metal-framed wall construction generally requires a continuous layer of rigid insulation to meet the mandatory minimum wall insulation levels and the prescriptive requirements since metal is more conductive than wood. In JA4, Table 4.2.4 and Table 4.2.5 have U-factors for metal-framed ceiling/roof constructions. Table 4.3.4 has U-factors for metal-framed walls. Table 4.4.4 and Table 4.4.5 have U-factors for metal-framed floors.

To comply prescriptively, a non-wood-framed assembly, such as a metal-framed assembly, must have an assembly U-factor that is equal to or less than the U-factor of the wood-framed assembly for that climate zone.

3.6.8 Structural Foam Wall Systems

The high performance structural foam wall assembly is an advanced assembly system that consists of closed cell spray foam (ccSPF) placed in the cavity bonded to wood framing and continuous rigid board insulation on the exterior of the frame. The bond that occurs between the ccSPF, the framing, and the continuous rigid insulation can provide code-compliant wind and seismic structural load resistance without the use of OSB sheathing (Figure 3-50).

A builder can configure the thicknesses of the cavity ccSPF, rigid insulation, and alternative cavity insulation to attain U-factors of 0.050 or better in 2x4 at 24" on center assembly. The structural foam wall assembly can be combined with advanced framing or OVE techniques to increase energy and resource efficiency while reducing material and labor costs.

Figure 3-50: Example Structural Foam Wall System

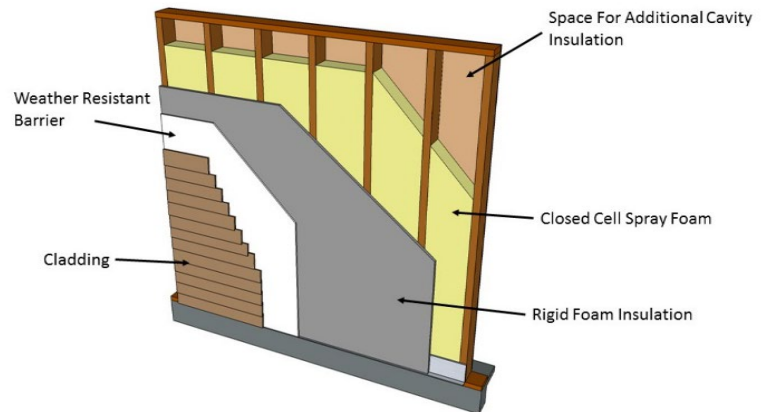

Source: California Energy Commission



Structural foam wall systems use ccSPF to insulate, air seal, and structurally bond exterior foam sheathing with wall framing to allow builders to construct 2x4 at 24" on center, while improving structural and thermal performance.

3.6.9 Controlled Ventilation Crawl Space

An energy credit can be taken in compliance software for controlled ventilation crawl spaces (CVC). This credit requires insulating the foundation stem wall, using automatically controlled crawl space vents, and covering the entire ground soil area with vapor retarder for moisture control on the crawl space floor.

Raised Floor Insulation Requirements



Buildings that have crawl space foundations must meet mandatory requirements for insulation of a raised floor separating the unconditioned crawl space from conditioned space above (§150.0[d]). There also are prescriptive requirements for insulating raised floors in §150.1(c)1C.

An alternative to underfloor insulation is insulating the stem wall of the foundation crawl space. Insulating the crawl space foundation can improve the thermal efficiency of the floor system by:

1. Reducing heat transfer into the unconditioned crawl space.
2. Reducing moisture buildup in the crawl space.
3. Minimizing insulation exposure to adverse weather prior to enclosing the building shell.

Eligibility Criteria. The following eligibility criteria in Residential Appendix RA4.5.1 are required to be met to use the CVC energy compliance credit:

1. **Ventilation:** All crawl space vents must have automatic vent dampers. Automatic vent dampers must be shown on the building plans and installed. Dampers shall be temperature actuated to be fully closed at about 40°F and fully open at about 70°F. Cross-ventilation consisting of the required vent area shall be distributed between opposing foundation walls.
2. **Insulation:** The R-value of insulation placed on the foundation stem wall shall be equal to or greater than the wall insulation above the raised floor. Stem wall insulation shall run vertically along the stem wall and horizontally across the crawl space floor for a distance of 2 feet (24 inches).
3. **Direct Earth Contact:** Foam plastic insulation used for crawl space insulation having direct earth contact shall be a closed-cell, water-resistant material and meet the slab edge insulation requirements for water absorption and water vapor transmission rate specified in the mandatory requirements (§110.8[g]1).
4. **Vapor Retarder:** A Class I or Class II vapor retarder rated as 1.0 perm or less must be placed over the earthen floor of the crawl space to reduce moisture entry and protect insulation from condensation in accordance with RA4.5.1. This requires essentially a polyethylene-type ground cover having a minimum 6 mil thickness (0.006 inch) or approved equal. The vapor retarder must be overlapped a minimum of 6 inches at joints and shall extend over the top of footings and piers. All overlapping of joints shall be sealed with tape, caulk, or mastic.
 - Penetrations, tears, and holes in the vapor barrier shall be sealed with tape, caulk, or mastic.
 - Edges of the vapor retarder shall be turned up a minimum of 4 inches at the stem wall and securely fastened and before insulation is installed.

- In sloping crawl space ground soil areas, the vapor retarder shall be securely held in place using fastening methods such as spiked with 5-inch gutter nails, then have proper sealing of penetration holes.
- The vapor retarder shall be shown on the plans.

Figure 3-51: Controlled Ventilation Crawl Space

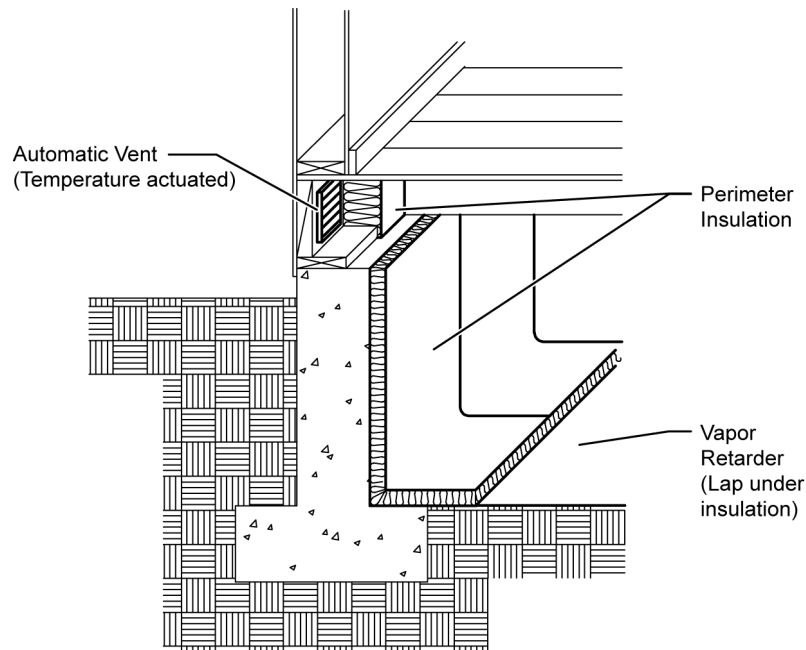

Source: California Energy Commission

Site Drainage. Crawl space buildings in particular are susceptible to moisture ponding when good drainage and/or moisture removal designs are not employed. All building designs should ensure that proper site engineering and drainage away from the building is maintained. This includes landscaping techniques that emphasize sound water management strategies.

Ground Water and Soils. Local groundwater tables at maximum winter recharge elevation should be below the lowest excavated elevation of the site foundation. Sites that are well-drained and that do not have surface water problems are generally good candidates for this stem wall insulation strategy. However, allowance for this alternative insulating technique is entirely at the enforcement agency's discretion. The building permit applicant should be prepared to provide supporting information that site drainage strategies (for example, perimeter drainage techniques) will prevent potential moisture concerns.

3.6.10 HERS-Verified Reduced Building Air Leakage RA3.8

An energy credit is allowed for single-family buildings through the performance approach when the rate of envelope air leakage of the building is less than the air leakage rate assumed for the standard design building of 5 ACH50.



A third-party HERS Rater shall verify the air leakage rate shown on compliance documentation through diagnostic testing of the air leakage of the building.

Blower Door Testing. The blower door air leakage testing involves closing all the windows and doors; pressurizing the house with a special fan, usually positioned in a doorway (Figure 3-52); and measuring the leakage rate, measured in cubic feet per minute at a 50 Pa pressure difference (CFM50).

The measurement procedure is described in Residential Appendix RA3.8 and was derived from the Residential Energy Services Network's (RESNET) Mortgage Industry National Home Energy Rating Standards, Standard 800, which is based on ASTM E779 airtightness measurement protocols. This procedure requires the use of software consistent with ASTM E779. This test method is intended to produce a measure of the airtightness of a building envelope for determining the energy credit allowance for reduced building air leakage.

Figure 3-52: Blower Door Testing



Source: California Energy Commission



Tips for Implementing the Reduced Building Air Leakage Compliance Credit

1. This procedure shall be used only to verify the building air leakage rate before the building construction permit is finalized when an energy credit for reduced air leakage is being claimed on compliance documentation.
2. The HERS Rater shall measure the building air leakage rate to ensure measured air leakage is less than or equal to the building air leakage rate stated on the certificate of compliance and all other required compliance documentation. HERS-verified building air leakage shall be documented on compliance forms.
3. This is a whole-building credit; therefore, no credit is allowed for the installation of envelope measures that may help reduce the air leakage rate of the building, such as for an exterior air retarding wrap or for an air barrier material or assembly meeting the requirements described in Section 3.5.8 under Quality Insulation Installation (QII).

3.7 Alternative Construction Assemblies

3.7.1 Log Homes

Log walls are typically made from trees that have been cut into logs that have not been milled into conventional lumber. Logs used for walls, roofs, and floor systems may be milled or laminated by the manufacturer or supplier to meet specific dimensions and fitting and finishing conditions.

Log homes are an alternative construction type used in some parts of California. Log home companies promote the aesthetic qualities of solid wood construction and can package the logs and deliver them directly to a building site. Some companies provide log wall, roof, and floor systems with special insulating channels or other techniques to minimize the effect of air infiltration between log members and to increase the thermal benefit of the logs.



Log walls do not have framing members like conventional wood stud walls. Section 150.0(c)3 says that opaque nonframed assemblies need to have an overall maximum U-factor of 0.102, which is equivalent to a 2x4 R-13 wood-framed assembly. Per JA4 Table 4.3.11, any log wall 8 inches or more in diameter would meet this requirement, but less than 8 inches would not.



In prescriptive compliance, log walls must meet the same thermal requirements as other construction types. The prescriptive requirements for mass walls are less stringent than the criteria for wood-framed walls. Reduced insulation is allowed because the effects of the thermal mass (interior and exterior) can compensate for less insulation. Footnotes 5 and 6 to Table 150.1-A define the prescriptive mass wall as having heat capacity (HC) 7.0 Btu/°F-ft² or more, depending on whether the insulation is interior or exterior.



For performance compliance, consult the compliance software vendor’s documentation for any unique modeling requirements for mass walls using values from the Joint Reference Appendices.

The thermal performance of log walls is shown in JA4 Table 4.3.11. The U-factor ranges from 0.132 for a 6-inch wall to 0.053 for a 16-inch wall. The U-factor of an 8-inch wall is 0.102, which complies with the mandatory U-factor requirements. U-factors for other log wall constructions (not shown in JA4) would have to be approved by the Energy Commission through the exceptional methods process.

Log walls have a heat capacity that exceeds conventional construction, as seen in JA4 Table 4.3.11 (Thermal Properties of Log Home Walls) (Table 3-15). The thermal mass effects of log home construction can be accounted for within the performance approach.

Table 3-15: Thermal Properties of Log Home Walls (JA4 Table 4.3.11)

		U-Factor	Heat Capacity (HC)
Log Diameter	A		
6"	1	0.132	5.19
8"	2	0.102	6.92
10"	3	0.083	8.65
12"	4	0.070	10.37
14"	5	0.060	12.10
16"	6	0.053	13.83

Air Infiltration. Air infiltration between log walls can be considerably different among manufacturers depending upon the construction technique used. For compliance, infiltration is always assumed to be equivalent to a wood-frame building. The builder should consider using a blower door test to find and seal leaks through the exterior walls.

3.7.2 Straw Bale

Straw bale construction is a building method that uses bales of straw (commonly wheat, rice, rye, and oat straw) as structural and insulating elements of the building. Straw bale construction is regulated within the CBC, and specific guidelines are established for moisture content, bale density, seismic bracing, weather protection, and other structural requirements.

The Energy Standards have determined specific thermal properties for straw bale walls and thermal mass benefits associated with this type of construction. The performance compliance approach can be used to model the heat capacity characteristics of straw bales.

Straw bales that are 22 inches by 16 inches are assumed to have a thermal resistance of R-30, when stacked so the walls are either 22 inches wide or 16 inches wide. The minimum density of load bearing walls is 7.0 lb/ft³, and this value or the actual density may be used for modeling straw bale walls in the performance approach. Specific heat is set to 0.32 Btu/lb-°F. Volumetric heat capacity (used in some computer programs) is calculated as density times specific heat. At a density of 7 lb/ft³, for example, the volumetric heat capacity of the straw bale is 2.24, and 6.34 Btu/ft³-°F for the entire wall assembly. See JA4 Table 4.3.12

The minimum dimension of the straw bales when placed in the walls must be 22 inches by 16 inches, and there are no restrictions on how the bales are stacked. Due to the higher resistance to heat flow across the grain of the straw, a bale laid on edge with a nominal 16-inch horizontal thickness has the same R-Value (R-30) as a bale laid flat.

The nature of straw bale construction provides an effective air barrier. For compliance, infiltration is assumed to be equivalent to framed walls.

3.7.3 Structural Insulated Panels (SIPs)

Structural insulated panels (SIPs) are a nonframed advanced construction system that consists of rigid foam insulation sandwiched between two sheets of board. The board can be sheet metal, plywood, cement, or oriented strand board (OSB), and the foam can be expanded polystyrene foam (EPS), extruded polystyrene foam (XPS) or polyurethane (PUR), or polyisocyanurate (ISO) foam.

SIPs combine several components of conventional building, such as studs and joists, insulation, vapor barrier, and air barrier. They can be used for many different applications, such as exterior walls, roofs, floors, and foundation systems. Little or no structural framing penetrates the insulation layer. Panels are typically manufactured at a factory and shipped to the job site in assemblies that can be as large as 8 ft by 24 ft.



SIPS U-Factors for Compliance

In the field, the SIPS panels are joined in one of three ways, as shown in Figure 3-53:

1. Single or double 2x splines
2. I-joists
3. With OSB splines.

The choice of these options affects thermal performance and structural capacity. The 2x and I-joist spline types fit in a recess of the foam core, between the two layers of plywood or OSB. Joint Appendix JA4 Table 4.2.3 contains U-factors for roof/ceiling assemblies, JA4 Table 4.3.2 has U-factors for SIPS wall assemblies, and JA4 Table 4.4.3 has U-factors for SIPS floor constructions. U-factors used for compliance must be taken from these tables or by using Commission-approved performance compliance software.

Figure 3-53: Methods of Joining SIPS Panels

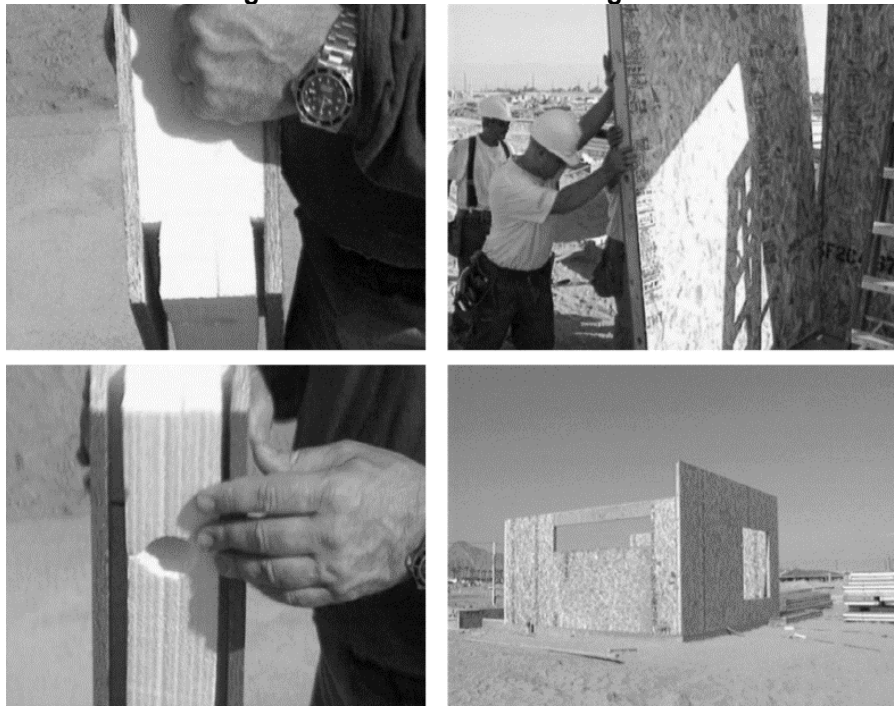

Source: California Energy Commission

3.7.4 Insulating Concrete Forms (ICF)

Insulating concrete forms (ICFs) are a system of formwork for concrete that stays in place as permanent building insulation and can be used for cast-in-place reinforced above- and below-grade concrete walls, floors, and roofs. They are interlocking modular units that can be dry-stacked (without mortar) and filled with concrete as a single concrete masonry unit (CMU). ICFs lock together externally and have internal metal or plastic ties to hold the outer layer(s) of insulation to create a concrete form and are manufactured from several materials, including expanded and extruded polystyrene foam, polyurethane foam, cement-bonded wood fiber, and cement-bonded polystyrene beads.

Three factors contribute to the energy efficiency of buildings using an ICF wall:

1. Continuous rigid insulation on both sides of a high-mass core
2. Elimination of thermal bridging from wood framing components
3. A high degree of airtightness inherent to this method of construction.

Climate zones with large daily temperature fluctuations have the greatest potential to benefit from the time lag and temperature dampening effects of these high-mass envelope systems. However, this combination of mass and insulation is beneficial in almost all climates, with the possible exception of mild coastal climate zones.

There are three basic types of ICFs:

1. Flat wall - A flat wall ICF results in a wall with a consistent and continuous thickness of concrete.
2. Waffle-grid - A waffle-grid ICF creates a concrete waffle pattern, an uninterrupted grid, with some concrete sections thicker than others.
3. Screen-grid - A screen-grid ICF consists of a discrete post-and-beam structure with the concrete completely encapsulated by the foam insulation, except at the intersection of posts and beams.

The insulating panels for all three ICF types are most commonly made from expanded polystyrene (EPS) and extruded polystyrene (XPS) rigid insulation boards. Insulating panels also are made from polyurethane (PUR), composites of cement and EPS, and composites of cement and shredded wood fiber, although these tend to be proprietary materials developed by the ICF manufacturer.

Plastic or metal cross-ties, consisting of two flanges and a web, separate the insulating panels and provide structural integrity during the pouring of concrete, resulting in uniform wall thickness. A variety of wall thicknesses can be obtained by changing the length of the web. The area of attachment of the cross-ties to the insulating form provides a secure connection surface located at standard spacing for mechanical attachment of finished materials to the interior and exterior of the wall. ICFs can be used to construct load-bearing and nonload-bearing walls and above- and below-grade walls, and can be designed to structurally perform in any seismic zone.

The ICF system is modular and stackable with interlocking edges. The materials can be delivered as preassembled blocks or as planks that require the flanges and web to be assembled during construction. The forms vary in height from 12" - 24" and are either 4' or 8' long. Vertical panels come in similar modules but are stacked vertically. ICF panels are typically available with core thickness ranging from 4" to 12".

The thermal aspects of ICFs are represented in Joint Appendix JA4 Table 4.3.13.

Table of Contents

- 4 Building HVAC Requirements 1
 - 4.1 Overview 1
 - 4.1.1 Introduction and Organization..... 1
 - 4.1.2 What’s New for the 2019 Energy Standards..... 1
 - 4.1.3 California Appliance Standards and Equipment Certification..... 3
 - 4.2 Heating Equipment..... 4
 - 4.2.1 Mandatory Measures for Heating Equipment..... 4
 - 4.2.2 Prescriptive Requirements for Heating Equipment 12
 - 4.2.3 Performance Compliance Options for Heating Equipment 12
 - 4.3 Cooling Equipment..... 13
 - 4.3.1 Mandatory Measures for Cooling Equipment..... 13
 - 4.3.2 Prescriptive Requirements for Cooling Equipment 21
 - 4.3.3 Performance Compliance Options for Cooling Equipment..... 23
 - 4.4 Air Distribution System Ducts, Plenums, Fans, and Filters 25
 - 4.4.1 Mandatory Measures for Air Distribution System Ducts, Plenums, Fans, and Filters 25
 - 4.4.2 Prescriptive Requirements for Air Distribution System Ducts, Plenums, and Fans 52
 - 4.4.3 Compliance Options for Air Distribution System Ducts, Plenums, and Fans 59
 - 4.4.4 Duct Installation Standards 63
 - 4.5 Controls..... 70
 - 4.5.1 Thermostats..... 70
 - 4.5.2 Zonal Control for Compliance Credit..... 71
 - 4.6 Indoor Air Quality and Mechanical Ventilation 74
 - 4.6.1 Compliance and Enforcement..... 77
 - 4.6.2 Typical Solutions for Single-Family Dwelling Unit Ventilation 80
 - 4.6.3 Typical Solutions for Multifamily Dwelling Unit Ventilation 86
 - 4.6.4 Dwelling Unit Ventilation Airflow Measurement..... 87
 - 4.6.5 Dwelling Unit Ventilation Rate (Section 4 of ASHRAE 62.2)..... 88
 - 4.6.6 Dwelling Unit Mechanical Ventilation Energy Consumption..... 95
 - 4.6.7 Local Exhaust (Section 5 of ASHRAE 62.2) 97
 - 4.6.8 Other Requirements (Section 6 of ASHRAE 62.2)..... 102

4.6.9	Air-Moving Equipment (Section 7 of ASHRAE 62.2)	111
4.7	Alternative Systems	117
4.7.1	Hydronic Heating Systems	117
4.7.2	Radiant Floor System	121
4.7.3	Evaporative Cooling	124
4.7.4	Ground-Source Heat Pumps	126
4.7.5	Solar Space Heating	126
4.7.6	Wood Space Heating	126
4.7.7	Gas Appliances	129
4.7.8	Evaporatively Cooled Condensers	129
4.7.9	Nonducted Systems	129
4.7.10	Ventilation Cooling	129
4.8	Refrigerant Charge	139
4.8.1	Refrigerant Charge Verification	139
4.9	Compliance and Enforcement	147
4.9.1	Design-Phase Documentation	147
4.9.2	Construction-Phase Documentation	149
4.9.3	Field Verification and/or Diagnostic Testing	149

4 Building HVAC Requirements

4.1 Overview

4.1.1 Introduction and Organization

This chapter addresses the requirements for heating, ventilating, and air-conditioning (HVAC) systems. The requirements are a source of information for mechanical system designers and installers, as well as energy consultants, Home Energy Rating System (HERS) Raters, and enforcement personnel.

Each section in this chapter outlines the mandatory measures and, when applicable, the prescriptive requirements or compliance options. These prescriptive requirements vary by climate zone and building type. If the building design does not achieve the minimum prescriptive requirements, consider using the performance compliance option that allows for making up the deficiencies with other HVAC or building features.

Each section of this chapter includes mandatory measures, prescriptive requirements and performance options. The chapter is organized under the following sections:

1. **Section 4.2** – Heating Equipment.
2. **Section 4.3** – Cooling Equipment.
3. **Section 4.4** – Air Distribution System Ducts, Plenums, and Fans.
4. **Section 4.5** – Controls.
5. **Section 4.6** – Indoor Air Quality and Mechanical Ventilation.
6. **Section 4.7** – Alternative Systems.
7. **Section 4.8** – Compliance and Enforcement.
8. **Section 4.9** – Refrigerant Charge.

Chapter 9 covers the heating and cooling requirements for additions to existing dwellings and for alterations to existing heating and cooling systems.

4.1.2 What's New for the 2019 Energy Standards

The following is an overview of the new HVAC measures for the *2019 Building Energy Efficiency Standards* (Energy Standards), including new compliance options that provide greater flexibility in complying with the Energy Standards when using the performance method.

4.1.2.1 Mandatory Features and Devices - §150.0

1. Fan efficacy requirements are 0.45 watts/cubic feet per minute (CFM) or less for gas furnace air-handling units or 0.58 watts/CFM or less for air-handling units that are not gas furnaces. This requirement applies to single zone and zonally controlled forced air systems (§150.0(m)13B and 13C).
2. Small-duct, high-velocity forced-air systems must meet a fan efficacy of 0.62 Watts/CFM or less and an airflow requirement of 250 CFM/ton or greater (§150.0(m)13D).
3. Two exceptions allow portions of a duct system to be uninsulated if specific conditions are met, as explained in Section 4.4.1 (Exceptions 1 and 2 to §150.0(m)1B).
4. Exceptions to requirements for a porous inner core flex duct is allowable if it has a nonporous layer or air barrier between the inner core and outer vapor barrier (§150.0(m)10).
5. There are changes to the mandatory air filtration requirements for space-conditioning systems with 10 feet or more of duct attached. The requirements affect the pressure drop and labeling of the filtration devices (§150.0(m)12).
6. Air filtration is now required on supply and balanced mechanical ventilation systems.
7. With the adoption of ASHRAE Standard 62.2-2016, higher mechanical ventilation rates will be required for single family units which vary by climate zone.

4.1.2.2 Prescriptive and Performance Compliance Approaches – §150.1

1. The refrigerant charge requirement in the prescriptive tables applies to all air conditioners and heat pumps, including small duct high, velocity systems (§150.1(c)7A).
2. Central fan-integrated ventilation systems used in prescriptive compliance must meet the mandatory fan efficacy requirement of 0.45 watts/CFM or less for gas furnace air-handling units or 0.58 watts/CFM or less for air-handling units that are not gas furnaces (§150.1(c)10).
3. Heat pumps used in performance compliance may require HERS verification of the heating seasonal performance factor (HSPF) and heating capacity as explained in Section 4.2.3 (§150.1(b)3).
4. Whole house fans used in performance compliance may require HERS verification of the airflow rate and fan efficacy as explained in Section 4.3.3 (§150.1(b)3).
5. Central fan ventilation cooling systems used in performance compliance may require HERS verification of the system airflow rate and fan efficacy at ventilation speed, as explained in Section 4.3.3 (§150.1(b)3).

4.1.2.3 Additions and Alterations – §150.2

The Energy Standards requirements for altered or new HVAC systems in existing homes are summarized and discussed in Chapter 9.

4.1.3 California Appliance Standards and Equipment Certification

§110.0 and §110.1

Most heating and cooling equipment installed in new California homes is regulated by the National Appliance Efficiency Conservation Act (NAECA) and/or the California *Appliance Efficiency Regulations (Title 20)*. Both the federal and state appliance standards apply to the manufacturing and sale of new equipment, whether for new construction, replacements, or repairs. The *Appliance Efficiency Regulations* are enforced at the point of sale (except central split-system air conditioners and central single package air conditioners, see Table 4-6), while the Energy Standards explained in this compliance manual are enforced by local enforcement agencies.

The equipment listed below is covered by the *Appliance Efficiency Regulations*. The manufacturer must certify that the equipment complies with the current *Appliance Efficiency Regulations* at the time of manufacture.

Appliances covered by the *Appliance Efficiency Regulations* include:

<ol style="list-style-type: none"> 1. Room air conditioners 2. Room air-conditioning heat pumps 3. Central air conditioners with a cooling capacity of less than 135,000 British thermal units per hour (Btu/hr) 4. Central air conditioning heat pumps 5. Gas-fired central furnaces 	<ol style="list-style-type: none"> 6. Gas-fired boilers 7. Gas-fired furnaces 8. Gas-fired floor furnaces 9. Gas-fired room heaters 10. Gas-fired duct furnaces 11. Gas-fired unit heaters
--	--

The *Appliance Efficiency Regulations* do not require certification for:

1. Electric resistance space heaters.
2. Oil-fired wall furnaces, floor furnaces, and room heaters. (Some are voluntarily listed with certified gas-fired furnaces.)

Equipment that does not meet the federal appliance efficiency standards may not be sold in California. Any equipment covered by the *Appliance Efficiency Regulations* and sold in California must have the date of manufacture permanently displayed in an accessible place on that equipment. This date is frequently included as part of the serial number.

Generally, equipment manufactured before the effective date of a new standard may be sold and installed in California indefinitely as long as the performance approach demonstrates energy compliance of the building using the lower efficiency of the

relevant appliances. An exception is central split-system air conditioners and central single package air conditioners *installed* in California. The U.S. Department of Energy (DOE) requires compliance with the minimum efficiencies specified in Table 4-6 at the time of installation.

The compliance and enforcement processes should ensure that all installed HVAC equipment regulated by the *Appliance Efficiency Regulations* is certified by the California Energy Commission.

4.1.3.1 Plan Review (Compliance)

During the plan review, the builder is responsible for demonstrating compliance with the *Appliance Efficiency Regulations* by providing the efficiency of the HVAC equipment that is to be installed. Typically, the builder does not identify the exact make or model at this point of the process. The plans examiner is responsible for verifying that the specified equipment efficiency complies with the *Appliance Efficiency Regulations*.

4.1.3.2 Field Inspection (Enforcement)

It is the field inspector's responsibility to visually verify that the product information on the installed HVAC equipment matches the efficiency approved by the plans examiner. To simplify the inspection, the field inspector may reference the CF2R-MCH-01-H form submitted by the builder/installing contractor.

4.2 Heating Equipment

This section addresses the requirements for heating equipment, including furnaces, boilers, heat pumps, and electric resistance equipment.

4.2.1 Mandatory Measures for Heating Equipment

4.2.1.1 Equipment Efficiency

§110.1 and §110.2(a)

The efficiency of most heating equipment is regulated by the National Appliance Energy Conservation Act of 1987 (NAECA, the federal appliance standard) and the California Appliance Efficiency Regulations. These regulations are not contained in the Energy Standards but are published separately. These regulations are referenced in §110.1. The Appliance Efficiency Regulations include definitions for all types of equipment and are regularly updated.

Note: The Appliance Efficiency Regulations that are in effect when the building permit is applied for will determine the minimum efficiency of the appliances identified in the compliance documentation.

The energy efficiency of other equipment is regulated by §110.2(a). Also, see the *Nonresidential Compliance Manual* for more information on larger equipment.

A. Gas and Oil-Fired Furnaces

The Appliance Efficiency Regulations (Title 20) require gas- and oil-fired central furnaces with outputs less than 225,000 Btu/hr to be rated according to the associated annual fuel utilization efficiency (AFUE). Gas- and oil-fired central furnaces with outputs greater than or equal to 225,000 Btu/hr are rated according to the respective thermal (or steady-state) efficiency. Refer to Table 4-1 for the applicable efficiency requirements.

Table 4-1: Minimum Efficiency for Gas- and Oil-Fired Central Furnaces

Appliance	Rated Input (Btu/hr)	Minimum Efficiency (%)	
		AFUE	Thermal Efficiency
Weatherized gas central furnaces with single phase electrical supply	< 225,000	81	—
Non-weatherized gas central furnaces with single phase electrical supply	< 225,000	80	—
Weatherized oil central furnaces with single phase electrical supply	< 225,000	78	—
Non-weatherized oil central furnaces with single phase electrical supply	< 225,000	83	—
Gas central furnaces	≥ 225,000	—	80
Oil central furnaces	≥ 225,000	—	81

Source: *California Appliance Efficiency Regulations Title-20 - Table E-5 and E-6*

Noncentral gas furnaces and space heaters manufactured on or after April 16, 2013, shall be certified to have AFUE values greater than or equal to those listed in Table 4-2.

Table 4-2: Minimum Heating Efficiency for Nonducted, Noncentral, Gas-Fired Heating Equipment

Type	Capacity	AFUE
Wall Furnace (fan type)	≤ 42,000 Btu/hr	75%
	> 42,000 Btu/hr	76%
Wall Furnace (gravity type)	≤ 27,000 Btu/hr	65%
	> 27,000 to ≤ 46,000 Btu/hr	66%
	> 46,000 Btu/hr	67%
Floor Furnace	≤ 37,000 Btu/hr	57%
	> 37,000 Btu/hr	58%
Room Heater	≤ 20,000 Btu/hr	61%
	> 20,000 to ≤ 27,000 Btu/hr	66%
	> 27,000 to ≤ 46,000 Btu/hr	67%
	> 46,000 Btu/hr	68%

Source: *California Appliance Efficiency Regulations Title 20 - Table E-2*

B. Heat Pumps and Electric Heating

Heat pumps shall be certified to have a HSPF or coefficient of performance (COP) equal to or better than those listed in Table 4-3.

There are no minimum appliance efficiency standards for electric-resistance or electric-radiant heating systems.

C. Gas- and Oil-Fired Central Boilers and Electric Boilers

Gas- and oil-fired central boilers shall be certified to have an AFUE or *Combustion Efficiency* equal to or better than those listed in Table 4-4.

Table 4-3: Minimum Heating Efficiency for Heat Pumps

Equipment Type	Reference	Configuration/Size	Minimum Heating Efficiency
Packaged terminal heat pumps (heating mode)	Table 110.2 E	Newly constructed or newly conditioned buildings or additions	$3.7 - (0.052 \times \text{Cap}^{1/1000}) = \text{COP}$
Packaged terminal heat pumps (heating mode)	Table 110.2 E	Replacements	$2.9 - (0.026 \times \text{Cap}^{1/1000}) = \text{COP}$
Single-phase air source heat pumps (NAECA)	Table C-3	< 65,000 Btu/hr cooling	Packaged 8.0 HSPF Split 8.2 HSPF
		Space constrained < 65,000 Btu/hr cooling capacity	7.4 HSPF
		Small duct, high velocity < 65,000 Btu/hr cooling capacity	7.2 HSPF
Three-phase air source heat pumps	Table C-4	< 65,000 Btu/hr	7.7 HSPF
		≥ 65,000 and <135,000	3.3 COP
		≥ 135,000 and <240,000	3.2 COP
		≥ 240,000 and <760,000	3.2 COP
Water-source heat pumps	Table C-5	≥ 65,000 and < 135,000 Btu/hr	4.2 COP
		≥ 135,000 Btu/hr, < 240,000 Btu/hr	3.9 COP
Single package vertical heat pumps	Table C-5	< 65,000 single-phase	3.0 COP
		< 65,000 3-Phase	3.0 COP
		≥ 65,000 and < 135,000	3.0 COP
		≥ 135,000 and < 240,000	2.9 COP

1. Cap = Cooling Capacity

Source: California Appliance Efficiency Regulation Title 20 and Energy Efficiency Standards

Table 4-4: Minimum Efficiency for Gas- and Oil-Fired Central Boilers

Appliance	Rated Input (Btu/hr)	Minimum Efficiency (%)	
		Thermal Efficiency	Combustion Efficiency
Gas steam boilers with single-phase electrical supply	< 300,000	80 ¹	AFUE
Gas hot water boilers with single-phase electrical supply	< 300,000	82 ^{1,2}	AFUE
Oil steam boilers with single-phase electrical supply	< 300,000	82	AFUE
Oil hot water boilers with single-phase electrical supply	< 300,000	84 ²	AFUE
Electric steam residential boilers	< 300,000	—	—
Electric hot water residential boilers	< 300,000	—	—
All other boilers with single-phase electrical supply	< 300,000	—	—
Steam boilers; gas-fired, except natural draft;	≥ 300,000	79	80
		77	80
		81	83
Steam boilers; gas-fired, natural draft	≥ 300,000	77	80
Steam boilers; oil-fired	≥ 300,000	81	83
¹ No constant burning pilot light design standard.			
² Automatic means for adjusting temperature design standard.			

Source: *California Appliance Efficiency Regulations Title 20 Table E-3 and E-4*

4.2.1.2 Heating System Controls

§150.0(i), §110.2(b), Exceptions to §110.2(b), §110.2(c), Exception to §110.2(c)

All heating systems, including heat pumps, must be controlled by a central energy management control system (EMCS) or by a setback thermostat. The setback thermostat must be capable of allowing the occupant to program temperature set points for at least four periods within a 24-hour time span.

No setback thermostat control is required for gravity gas wall heaters, floor heaters, room heaters, fireplaces, wood stoves, and noncentral electric heaters.

Any heat pump with supplementary electric resistance heating requires controls with two capabilities to limit the electric resistance heating. The first required capability is

to set the cut-on and cut-off temperatures for the heat pump and supplementary electric resistance heating at different levels.

For example, if the heat pump begins heating when the inside temperature reaches 68°F, the electric resistance heating may be set to come on if the temperature goes below 65°F if the heat pump alone could not maintain the set point of 68°F. Also, there must be an “off” mode that automatically shuts off the electric resistance when the inside temperature reaches 68°F.

The second control capability must prevent the supplementary electric resistance heater from operating if the heat pump alone can meet the heating load, except during defrost. There is a limited exception to this second function for “smart thermostats” that provides: intelligent recovery, staging, ramping, or another control mechanism that prevents the unnecessary operation of supplementary electric resistance heating when the heat pump alone can meet the heating load.

To meet the thermostat requirements, a thermostat for a heat pump must be a “smart thermostat” that minimizes the use of supplementary heating during startup and recovery from setbacks.

Note: Room air conditioner heat pumps are not required to comply with the thermostat requirements.

4.2.1.3 Equipment Sizing

§150.0(h)1 and 2

The Energy Standards do not set limits on the sizing of heating equipment, but they do require that heating loads be calculated for new heating systems. Oversized equipment typically operates less efficiently and can create comfort problems due to excessive cycling and improper airflow.

Acceptable load calculation procedures include methods described in the following publications:

1. *The ASHRAE Handbook – Equipment*
2. *The ASHRAE Handbook – Applications*
3. *The ASHRAE Handbook – Fundamentals*
4. *The SMACNA Residential Comfort System Installation Manual*
5. *ACCA Manual J*

The Energy Standards require that the outdoor design conditions for load calculations be selected from Reference Joint Appendix JA2 and that the indoor design temperature for heating load calculations be 68°F.

The outdoor design temperature must be no lower than the “heating winter median of extremes,” as listed in the Reference Joint Appendix JA2.

If the actual city location for a project is not included in Reference Joint Appendix JA2, or if the data given for a particular city do not match the conditions at the actual

site as well as that given for another nearby city, consult the local building department for guidance.

The load calculations must be submitted with the compliance documentation when requested by the building department.

The load calculations may be prepared by 1) a mechanical engineer, 2) the mechanical contractor who is installing the equipment or 3) someone who is qualified to do so in the State of California according to Division 3 of the Business and Professions Code.

The Business and Professions Code does not prohibit an unlicensed person from preparing plans, drawings, or specifications for single-family dwelling units of wood-frame construction not more than two stories and basement in height, or for certain buildings containing no more than four dwelling units of wood-frame construction not more than two stories and basement in height. However, licensure is required for apartment or condominium complexes.

4.2.1.4 Standby Losses and Pilot Lights

§110.5 and §110.2(d)

Fan-type central furnaces may not have a continuously burning pilot light. This requirement does not apply to wall furnaces, floor furnaces, or any gravity-type furnace. Household cooking appliances also must not have a continuously burning pilot light, except for those without an electrical supply voltage connection and in which each pilot consumes less than 150 Btu/hr.

Larger gas-fired and oil-fired forced air furnaces with input ratings equal to or greater than 225,000 Btu/h (which is bigger than a typical residential furnace) must also have an intermittent ignition device (IID) and either power venting or a flue damper.

A vent damper is an acceptable alternative to a flue damper for furnaces where combustion air is drawn from the conditioned space. All furnaces with input ratings equal to or greater than 225,000 Btu/h, including electric furnaces, that are not within the conditioned space must have jacket losses not exceeding 0.75 percent of the input rating.

4.2.1.5 Pipe Insulation

§150.0(j)2C, §150.0(j)3, §120.3

The piping for heat pumps and for steam and hydronic heating systems shall meet the insulation requirements provided below in Table 4-5 when the insulation is outside conditioned space, it requires protection from damage caused by environmental conditions. The insulation must be rated for outdoor use or covered with a material that can withstand outdoor conditions. Examples of these types of coverings are aluminum, sheet metal, painted canvas, plastic cover, or, if the insulation is cellular foam, a coating that is water-retardant and shields from solar radiation. Moreover, the insulation used for the refrigerant suction line of a heat pump must be Class I or Class II vapor retardant.

Table 4-5: Insulation Requirements for Heating System Piping

Fluid Operating Temperature Range (°F)	Insulation Conductivity			Nominal Pipe Diameter (in inches)						
	Conductivity (in Btu·in/h·ft ² ·°F)	Mean Rating Temperature (°F)		< 1	1 to <1.5	1.5 to < 4	4 to < 8	8 and larger		
Space-Heating and Service Water-Heating Systems (Steam, Steam Condensate, Refrigerant, Space Heating, Service Hot Water)				Minimum Pipe Insulation Required (Thickness in inches or R-value)						
Above 350	0.32-0.34	250	Inches	4.5	5.0	5.0	5.0	5.0		
			R-value	R 37	R 41	R 37	R 27	R 23		
251-350	0.29-0.32	200	Inches	3.0	4.0	4.5	4.5	4.5		
			R-value	R 24	R 34	R 35	R 26	R 22		
201-250	0.27-0.30	150	Inches	2.5	2.5	2.5	3.0	3.0		
			R-value	R 21	R 20	R 17.5	R 17	R 14.5		
141-200	0.25-0.29	125	Inches	1.5	1.5	2.0	2.0	2.0		
			R-value	R 11.5	R 11	R 14	R 11	R 10		
105-140	0.22-0.28	100	Inches	1.0	1.5	1.5	1.5	1.5		
			R-value	R 7.7	R 12.5	R 11	R 9	R 8		
				Nominal Pipe Diameter (in inches)						
				< 1	1 to <1.5	1.5 to < 4	4 to < 8	8 and larger		
Space-Cooling Systems (Chilled Water, Refrigerant and Brine)				Minimum Pipe Insulation Required (Thickness in inches or R-value)¹						
40-60	0.21-0.27	75	Inches	Nonres 0.5	Res 0.75	Nonres 0.5	Res 0.75	1.0	1.0	1.0
			R-value	Nonres R 3	Res R 6	Nonres R 3	Res R 5	R 7	R 6	R 5
Below 40	0.20-0.26	50	Inches	1.0	1.5	1.5	1.5	1.5		
			R-value	R 8.5	R 14	R 12	R 10	R 9		

Footnote to TABLE 4-5:

1. These thickness are based on energy efficiency considerations only. Issues such as water vapor permeability or surface condensation sometimes require vapor retarders or additional insulation.

From Table 120.3 A of the *Building Energy Efficiency Standards*

4.2.2 Prescriptive Requirements for Heating Equipment

§150.1(c)6

Prescriptive component compliance requires the installation of a gas heating system or heat pump that meets the required minimum energy efficiency. (See Table 4-1 through Table 4-4)

Supplemental heating systems are allowed prescriptively, and the designer may elect to provide supplemental heating to a space such as a bathroom. In this instance, the supplemental heating system must be installed in a space that is served by the primary heating system and must have a thermal capacity of less than 2 kilowatts (kW) or 7,000 Btu/hr while being controlled by a time-limiting device not exceeding 30 minutes. Electric resistance and electric radiant heating installation are allowed as the primary heating system only when using the performance compliance method.

When using the prescriptive compliance approach, no additional credit is given for selecting equipment that is higher efficiency than what is required by the prescriptive component package.

4.2.3 Performance Compliance Options for Heating Equipment

§150.1(b)3

There is one option for receiving compliance credit related to the heating system. This credit is available through the performance compliance method.

4.2.3.1 High-Efficiency Heating

Heating system efficiencies are explained in Section 4.2.1.1. The minimum efficiency is required for prescriptive compliance. When the performance compliance approach is used, additional compliance credit may be available from higher efficiency heating equipment which can be used to offset less efficient building features.

When a heat pump is providing space heating, if the efficiency used for compliance is higher than the minimum required HSPF, the system efficiency must be verified by a HERS Rater. Moreover, because the capacity of the heat pump affects the amount of back-up electric resistance heating required to attain and maintain comfort conditions, if the capacity proposed for compliance is different than the default capacity used in the performance compliance software, the Air Conditioning, Heating, and Refrigeration Institute (AHRI) ratings for heating capacity of the installed heat pump must be verified by a HERS Rater to confirm the heating

capacities at 47 degrees F and 17 degrees F are equal or greater than the heating capacities given on the certificate of compliance. See Residential Appendix RA3.4.4.2 for more information about this HERS verification

4.3 Cooling Equipment

This section addresses the requirements for space-cooling equipment.

4.3.1 Mandatory Measures for Cooling Equipment

4.3.1.1 Equipment Efficiency

§110.1 and §110.2(a)

The efficiency of most cooling equipment is regulated by NAECA (the federal appliance standard) and the California Appliance Efficiency Regulations. These regulations are not contained in the Energy Standards but are referenced in §110.1. The energy efficiency of larger equipment is regulated by §110.2(a). See the *Nonresidential Compliance Manual* for information on larger equipment.

A. Central, Single-Phase Air Conditioners and Air Source Heat Pumps (Under 65,000 Btu/hr)

The central, single-phase air conditioners and air source heat pumps that are most commonly installed in homes have a capacity less than 65,000 Btu/hr. The *Appliance Efficiency Regulations* for this equipment require minimum seasonal energy efficiency ratios (SEER).

The SEER of all new central, single-phase air conditioners and air source heat pumps with output less than 65,000 Btu/h shall be certified to the Energy Commission to have values no less than the values listed in Table 4-6.

**Table 4-6: Minimum Cooling Efficiencies for Central Air Conditioners and Heat Pumps
(Cooling Capacity Less Than 65,000 Btu/hour)
(NR = No Requirement)**

Appliance	Type	SEER	EER
Central Air Conditioners ¹	Split-System <45,000 Btuh	14	12.2
	Split-System ≥45,000 Btuh	14	11.7
	Single-Package	14	11.0
Central Air Source Heat Pumps	Split-System	14	NR
	Single-Package	14	NR
Space-Constrained Air Conditioner	Split-System	12	NR
	Single-Package	12	NR
Space-Constrained Heat Pump	Split-System	12	NR
	Single-Package	12	NR
Small-Duct, High-Velocity Air Conditioner	All	12	NR
Small-Duct, High-Velocity Heat Pump	All	12	NR

Source: *California Appliance Efficiency Regulations, Title 20, Table C-3* and Federal Appliance Standards (NAECA)

B. Other Air Conditioners and Heat Pumps

Appliance Efficiency Regulations

The current *Appliance Efficiency Regulations* for three-phase models, larger-capacity central air conditioners and heat pumps, and all room air conditioners and room air conditioner heat pumps shall be certified to the Energy Commission by the manufacturer to have values no less than the values listed in Table 4-7 and Table 4-8.

Table 4-7: Minimum Cooling Efficiency for Three-Phase Models and Larger Capacity Central Air Conditioners and Heat Pumps

Equipment Type	Size Category	SEER or EER
Central Air-Conditioners	< 65,000 Split-System*	13.0 SEER
	< 65,000 Single-Packaged*	13.0 SEER
	≥65,000 Btu/h but <135,000 Btu/hr	11.2 ¹ EER 11.0 ² EER
	≥135,000 Btu/hr but <240,000 Btu/hr	11.0 ¹ EER 10.8 ² EER
	≥240,000 Btu/hr but <760,000 Btu/hr	10.0 ¹ EER

		9.8 ² EER
Central Air-Source Heat Pumps	< 65,000 Split-System*	13.0 SEER
	< 65,000 Single-Packaged*	13.0 SEER
	≥ 65,000 Btu/h but <135,000 Btu/hr	11.0 ¹ EER 10.8 ² EER
	≥135,000 Btu/h but <240,000 Btu/hr	10.6 ¹ EER 10.4 ² EER
	≥240,000 Btu/h but <760,000 Btu/hr	9.5 ¹ EER 9.3 ² EER
Central Water-Source Heat Pumps	< 17,000 Btu/hr	11.2 EER
	≥ 17,000 Btu/h and < 65,000 Btu/hr	12.0 EER
	≥ 65,000 Btu/h and < 135,000 Btu/hr	11.9 EER
	≥ 135,000 Btu/h and < 240,000 Btu/hr	12.3 EER
	≥ 240,000 Btu/h and < 760,000 Btu/hr	12.2 EER
Water-Cooled Air Conditioners	< 17,000 Btu/hr	12.1 EER
	< 17,000 < 65,000 Btu/hr	12.1 EER
	≥ 65,000 Btu/hr and < 135,000 Btu/hr	12.1 ³ EER
	≥ 135,000 Btu/hr and < 240,000 Btu/hr	12.5 ³ EER
	≥ 240,000 Btu/hr and < 760,000 Btu/hr	12.4 ³ EER
<p>* Three-phase models only 1 Applies to equipment that has electric resistance heat or no heating. 2 Applies to equipment with all other heating-system types that are integrated into the unitary equipment. Deduct 0.2 from the required EER for units with heating sections other than electric resistance heat.</p>		

Source: California Appliance Efficiency Regulations
 Table C-4, C-5

Table 4-8: Minimum Cooling Efficiency for Noncentral Space-Cooling Equipment

Equipment Type	Size Category (Input)	Minimum Efficiency
Room Air Conditioners, With Louvered Sides	< 6,000 Btu/hr	11.0 EER
	≥ 6,000 Btu/hr and < 7,999 Btu/hr	11.0 EER
	≥ 8,000 Btu/hr and < 13,999 Btu/hr	10.9 EER
	≥ 14,000 Btu/hr and < 19,999 Btu/hr	10.7 EER
	≥ 20,000 Btu/h and < 27,999 Btu/h	9.4 EER
	≥ 28,000 Btu/h	9.0 EER
Room Air Conditioners, Without Louvered Sides	< 6,000 Btu/h	10.0 EER
	≥ 6,000 Btu/hr and < 7,999 Btu/hr	10.0 EER
	≥ 8,000 Btu/hr and < 10,999 Btu/hr	9.6 EER

	≥ 11,000 Btu/hr and - 13,999 Btu/hr	9.5 EER
	≥ 14,000 Btu/hr and - 19,999 Btu/hr	9.3 EER
	≥ 20,000 Btu/hr	9.4 EER
Room Air Conditioner Heat Pumps With Louvered Sides	< 20,000 Btu/hr	9.8 EER
	≥ 20,000 Btu/hr	9.3 EER
Room Air Conditioner Heat Pumps Without Louvered Sides	< 14,000 Btu/hr	9.3 EER
	≥ 14,000 Btu/hr	8.7 EER
Casement-Only Room Air Conditioner	All Capacities	9.5 EER
Casement-Slider Room Air Conditioner	All Capacities	10.4 EER
PTAC (cooling mode) Newly Constructed or Newly Conditioned Buildings or Additions	All Capacities	$14.0 - (0.300 \times \text{Cap}/1000) = \text{EER}$
PTAC (cooling mode) Replacements	All Capacities	$10.9 - (0.213 \times \text{Cap}/1000) = \text{EER}$
PTHP (cooling mode) Newly Constructed or newly conditioned buildings or Additions	All Capacities	$14.0 - (0.300 \times \text{Cap}/1000) = \text{EER}$
PTHP (cooling mode) Replacements	All Capacities	$10.8 - (0.213 \times \text{Cap}/1000) = \text{EER}$
SPVAC (cooling mode)	< 65,000 Btu/hr	11.0 EER
	≥ 65,000 Btu/hr and < 135,000 Btu/hr	10.0 EER
	≥ 135,000 Btu/hr and < 240,000 Btu/hr	10.0 EER
SPVHP (cooling mode)	< 65,000 Btu/hr	11.0 EER
	≥ 65,000 Btu/hr and < 135,000 Btu/hr	10 EER
	≥ 135,000 Btu/hr and < 240,000 Btu/hr	10 EER
Cap. = Cooling Capacity (Btu/hrr)		
<i>Note:</i> Including room air conditioners and room air conditioner heat pumps, package terminal air conditioners (PTAC), package terminal heat pumps (PTHP), single-package vertical air conditioners (SPVAC), and heat pumps (SPVHP).		

Source: *California Appliance Efficiency Regulations Title 20*, Table B-3, the Energy Standards Table 110.2-E

4.3.1.2 Insulation for Refrigerant Lines in Split-System Air Conditioners

§150.0(j)2 and 3, §150.0(m)9

Two refrigerant lines connect the indoor and outdoor units of split-system air conditioners and heat pumps: the liquid line (the smaller diameter line) and the suction line (the larger diameter line).

If the liquid line is at an elevated temperature relative to outdoor and indoor temperatures, it should not be insulated. In those areas, heat escaping from it is helpful.

The suction line carries refrigerant vapor that is cooler than ambient in the summer and (with heat pumps) warmer than ambient in the winter. This line must be insulated to the required thickness (in inches) as specified in Table 4-9.

Table 4-9: Insulation Requirements for Split-System Refrigerant Piping

<u>Fluid Operating Temperature Range (°F)</u>	<u>Insulation Conductivity</u>			<u>Nominal Pipe Diameter (in inches)</u>			
	<u>Conductivity (in Btu·in/h·ft²·°F)</u>	<u>Mean Rating Temperature (°F)</u>		<u>< 1</u>		<u>1 to <1.5</u>	
<u>Space heating and Service Water Heating Systems (Steam, Steam Condensate, Refrigerant, Space Heating, Service Hot Water)</u>				<u>Minimum Pipe Insulation Required (Thickness in inches or R-value)</u>			
<u>105-140</u>	<u>0.22-0.28</u>	<u>100</u>	<u>Inches</u>	<u>1.0</u>		<u>1.5</u>	
			<u>R-value</u>	<u>R 7.7</u>		<u>R 12.5</u>	
<u>Space-Cooling Systems (Chilled Water, Refrigerant and Brine)</u>				<u>Minimum Pipe Insulation Required (Thickness in Inches or R-value)¹</u>			
<u>40-60</u>	<u>0.21-0.27</u>	<u>75</u>	<u>Inches</u>	<u>Nonres 0.5</u>	<u>Res 0.75</u>	<u>Nonres 0.5</u>	<u>Res 0.75</u>
			<u>R-value</u>	<u>Nonres R 3</u>	<u>Res R 6</u>	<u>Nonres R 3</u>	<u>Res R 5</u>
<u>Below 40</u>	<u>0.20-0.26</u>	<u>50</u>	<u>Inches</u>	<u>1.0</u>		<u>1.5</u>	
			<u>R-value</u>	<u>R 8.5</u>		<u>R 14</u>	
Footnote to TABLE 4-9:							
1. <u>These thickness are based on energy efficiency considerations only. Issues such as water vapor permeability or surface condensation sometimes require vapor retarders or additional insulation.</u>							

Source: Table 120.3-A of the Energy Standards

Insulation used for refrigerant suction lines located outside a condition space, must include a Class I or Class II vapor retarder. The vapor retarder and insulation must be protected from physical damage, UV deterioration, and moisture with a covering that can be removed for equipment maintenance without destroying the insulation. Insulation is typically protected by aluminum, sheet metal jacket, painted canvas, or plastic cover. Adhesive tape should not be used as insulation protection because removal of the tape will damage the integrity of the original insulation during preventive maintenance.

Figure 4-1: Refrigerant Line Insulation

Source: Airex Manufacturing Inc.

4.3.1.3 Outdoor Condensing Units

§150.0(h)3

Any obstruction of the airflow through the outdoor unit of an air conditioner or heat pump lowers efficiency. Dryer vents are prime sources for substances that clog outdoor coils and sometimes discharge substances that can cause corrosion. Therefore, condensing units shall not be placed within 5 feet of a dryer vent. This requirement is applicable to new installations and to replacements. Regardless of location, condenser coils should be cleaned regularly in all homes. The manufacturer installation instructions may include requirements for minimum horizontal and vertical distance to surrounding objects that should be met if greater than the minimum distance required by the Energy Standards.

Figure 4-2: Noncompliant Condensing Unit Clearance From Dryer Vents

Source: California Energy Commission

Liquid line filter driers are components of split system air-conditioners and split system heat pumps that are installed in the refrigerant line to remove moisture and particles, from the refrigerant stream. These contaminants may be introduced in the refrigerant as a result of improper flushing, evacuation, and charging procedures, causing the efficiency and capacity of the air conditioner to be impaired, or damaging components. If required by manufacturer's instructions, liquid line filter driers must be installed. Sometimes, liquid line filter driers are preinstalled by manufacturers within condensing units, which makes it difficult for technicians to access. Because of this difficulty, manufacturers have begun changing this practice by installing liquid line filter driers outside condensers, so that they can be easily serviced by technicians and more easily verified by HERS Raters.

The quality of the filter dryer installation impacts the effectiveness of the liquid line filter dryer, as some liquid line filter driers can be installed without regard to the direction of refrigerant flow. Heat pumps, for example, allow refrigerant flow in both directions. However, in other air conditioners where refrigerant flow occurs in only one direction, correct orientation of the liquid line filter dryer is important.

4.3.1.4 Equipment Sizing

§150.0(h)

Similar to heating equipment, the Energy Standards do not set limits on the size of cooling equipment, but they do require that cooling loads be calculated for new cooling systems. Avoid oversizing the cooling components since oversizing may adversely affect the efficiency of the system. Ducts must be sized correctly, otherwise the system airflow rate may be restricted, adversely affecting the efficiency of the system and preventing the system from meeting the mandatory minimum airflow rate requirements.

The outdoor design conditions for load calculations must be selected from Reference Joint Appendix JA2, Table 2-3, using values no greater than the "1.0 percent cooling dry bulb" and "mean coincident wet bulb" values listed. The indoor design temperature for cooling load calculations must be 75°F. Acceptable load calculation procedures include methods described in:

1. *The ASHRAE Handbook – Equipment*
2. *The ASHRAE Handbook – Applications*
3. *The ASHRAE Handbook – Fundamentals*
4. The SMACNA Residential Comfort System Installation Manual.
5. *ACCA Manual J*

Cooling load calculations must be submitted with compliance documentation when requested by the building department. The load calculations may be prepared by 1) a mechanical engineer, 2) the mechanical contractor who is installing the equipment or 3) someone who is qualified to do so in the State of California according to Division 3 of the Business and Professions Code.

4.3.1.5 Hole for Static Pressure Probe (HSPP) or Permanently Installed Static Pressure Probe (PSPP)

§150.0(m)13

Space-conditioning systems that use forced air ducts to cool occupiable space shall have a hole for the placement of a static pressure probe (HSPP) or permanently installed static pressure probe (PSPP) installed downstream from the evaporator coil.

The HSPP or PSPP must be installed in the required location, in accordance with the specifications detailed in Reference Residential Appendix RA3.3. The HSPP or PSPP is required to promote system airflow measurement when using devices/procedures that depend on supply plenum pressure measurements. The HSPP or PSPP allows HERS Raters to perform the required diagnostic airflow testing in a nonintrusive manner, by eliminating the necessity for the raters to drill holes in the supply plenum for placement of pressure measurement probes.

The size and placement of the HSPP/PSPP shall be in accordance with RA3.3.1.1 and shall be verified by a HERS Rater. In the event that the HSPP/PSPP cannot be installed as shown in Figure RA3.3-1 because of the configuration of the system or that the location is not accessible, an alternative location may be provided that can accurately measure the average static pressure in the supply plenum. If an alternative location cannot be provided, then the HSPP/PSPP is not required to be installed. The HERS Rater will verify this. Not installing an HSPP/PSPP will limit the airflow measurement method to either a powered flow hood or passive (traditional) flow hood.

When the mandatory measure for minimum system airflow rate is in effect (entirely new systems), there must be a hole in the supply plenum, provided by the installing contractor, for the placement of a static pressure probe (HSPP). Alternatively, a permanently installed static pressure probe (PSPP) must be installed in the same location.

This requirement also applies when the plenum pressure matching method or the flow grid method of airflow measurement is used by either the installer or the rater to verify airflow in an altered system. The HSPP/PSPP must be installed by the installer, not the rater.

See Air Distribution Ducts, Plenums, and Fans Section 4.4 for discussion regarding mandatory sizing/airflow requirements for ducted systems with cooling.

4.3.2 Prescriptive Requirements for Cooling Equipment

§150.1(c)7

Prescriptive compliance does not require that a cooling system be installed. However, if one is to be installed, the cooling equipment efficiency requirements are specified by the mandatory measures (See Section 4.3.1 above)

Using the prescriptive compliance approach, no additional credit is given for selecting equipment that is higher than what is required by the prescriptive component package.

Prescriptive requirements for air-cooled air conditioners and air-source heat pumps installed in Climate Zones 2 and 8 through 15 necessitates the installation of a measurement access hole (MAH), refrigerant charge verification (RCV), and minimum system airflow verification. The minimum system airflow installation and RCV must be performed by the installer and/or HERS Rater. The MAH provides a nonintrusive means of measuring return air temperature, which is a parameter important to the RCV process. The alternative to RCV by a HERS Rater is the installation of a refrigerant fault indicator display. When installing a fault indicator display, the installer must still perform a RCV.

Note: The refrigerant charge verification is discussed below (4.3.2.3) and in greater detail later in Section 4.8.

4.3.2.1 Measurement Access Hole (MAH).

The MAH provides a nonintrusive means for refrigerant charge verification by HERS Raters and other third-party inspectors. They eliminate the need for raters/inspectors to drill holes into the installed air conditioning equipment enclosures for placement of the temperature sensors required by the refrigerant charge verification test procedures described in the Reference Residential Appendix RA3.2.

Installation of MAH must be performed by the installer of the air conditioner or heat pump equipment according to the specifications given in Reference Residential Appendix RA3.2.

The MAH feature consists of one 5/8-inch (16 millimeters [mm]) diameter hole in the return plenum, upstream from the evaporator coil. (See Figure RA3.2-1 in Reference Residential Appendix RA3.2.)

4.3.2.2 Minimum System Airflow

Ducted forced air cooling systems must comply with the minimum system airflow rate of greater than or equal to 350 CFM per ton, or 250 CFM/ton for small duct, high velocity systems, when performing the refrigerant charge verification. The airflow is important when performing the refrigerant charge verification to validate the measured values for pressure and temperature. The correct airflow will also improve the performance of the air-conditioning equipment.

The airflow verification procedure is documented in Reference Residential Appendix RA3.3.

4.3.2.3 Refrigerant Charge Verification (RCV)

The prescriptive standards for Climate Zones 2 and 8-15 require that a HERS rater verify that ducted air-cooled air conditioners, ducted air-source heat pumps, small-duct high-velocity systems; and mini-split systems have the correct refrigerant charge. The RCV procedures are documented in Reference Residential Appendix RA1.2, RA2.4.4, and RA3.2.

Refrigerant charge refers to the actual amount of refrigerant present in the system. Excessive refrigerant charge (overcharge) reduces system efficiency and can lead to premature compressor failure. Insufficient refrigerant charge (undercharge) also reduces system efficiency and can cause compressors to overheat. Ensuring correct refrigerant charge can significantly improve the performance of air-conditioning equipment. *Refrigerants* are the working fluids in air-conditioning and heat-pump systems that absorb heat energy from one area (through the evaporator), transfer, and reject it to another (through the condenser).

4.3.2.4 Fault Indicator Display

The installation of a fault indicator display (FID) may be used as an alternative to the prescriptive requirement for HERS diagnostic testing of the refrigerant charge in air conditioners and heat pumps. The installation of an FID does not preclude the HVAC installer from having to properly charge the system with refrigerant. The FID provides real-time information to the building occupant about the status of the system refrigerant charge, metering device, and system airflow. The FID will monitor and determine the operating performance of air conditioners and heat pumps and provide visual indication to the system owner or operator if the refrigerant charge, airflow, or metering device performance of the system does not conform to approved target parameters for minimally efficient operation. Thus, if the FID signals the owner/occupant that the system requires service or repair, the occupant can immediately call for a service technician to make the necessary adjustments or repairs. An FID can provide significant benefit to the owner/occupant by alerting the owner/occupant to the presence of inefficient operation that could result in excessive energy use/costs over an extended period. An FID can also indicate system performance faults that could result in system component damage or failure if not corrected, thus helping the owner/occupant avoid unnecessary repair costs.

Fault indicator display technologies are expected to be installed at the factory; otherwise, they may be installed in the field according to manufacturer's specifications. Reference Joint Appendix JA6 contains more information about FID technologies.

The presence of an FID on a system must be field-verified by a HERS Rater. See Reference Residential Appendix RA3.4.2 for the HERS verification procedure, which consists of a visual verification of the presence of the installed FID technology. The rater must inspect to see that the visual indication display component of the installed FID technology is mounted adjacent to the thermostat of the split system. When the outdoor temperature is greater than 55°F, the rater must also observe that the system reports no system faults when the system is operated continuously for at

least 15 minutes when the indoor air temperature returning to the air conditioner is at or above 70°F. When the outdoor temperature is below 55°F, the rater must observe that the FID performs a self-diagnosis and indicates that the sensors and internal processes are operating properly.

4.3.3 Performance Compliance Options for Cooling Equipment

There are several options for receiving compliance credit related to the cooling system. These credits are available through the performance compliance method.

4.3.3.1 High-Efficiency Air Conditioner

Air conditioner efficiencies are determined according to federal test procedures. The efficiencies are reported in terms of seasonal energy efficiency ratio (SEER) and energy efficiency ratio (EER). Savings can be achieved by choosing an air conditioner that exceeds the minimum efficiency requirements.

The EER is the full-load efficiency at specific operating conditions. It is possible that two units with the same SEER can have different EERs. In cooling climate zones of California, for two units with a given SEER, the unit with the higher EER is more effective in saving energy. Using the performance compliance method, credit is available for specifying an air conditioner with an EER greater than the minimum (Table 4-6). When credit is taken for a high EER and/or SEER, field verification by a HERS Rater is required. (See Reference Residential Appendix RA3.4.4).

4.3.3.2 Air Handler Fan Efficacy and System Airflow

It is mandatory that central forced-air systems operate at fan efficacy values less than or equal to

- 0.58 watts/CFM for air handlers that are not gas furnaces.
- 0.45 watts/CFM for gas furnaces.
- 0.62 watts/CFM for small-duct high-velocity system air handlers.

These central forced-air systems also must operate at airflow rates of at least 350 CFM per nominal cooling ton, or 250 CFM/ton for small-duct high-velocity systems. Performance compliance credits are available for demonstrating the installation of a high-efficiency system with a lower fan wattage and/or higher airflow than the mandatory requirements. Compliance with these credits can be achieved by installing a well-designed duct system and can be assisted by a high-efficiency fan. There are two possible performance compliance credits:

1. The performance compliance method allows the user's proposed fan efficacy to be entered and credit earned if it is lower than the default mandatory values. To obtain this credit for a system with cooling, the system airflow must meet the mandatory requirement of at least 350 CFM/ton of nominal cooling capacity.
2. The performance compliance method allows the user's proposed system airflow to be entered and credit earned if it is higher than the default of 350

CFM/ton of nominal cooling capacity. To obtain this credit, the fan efficacy must meet the mandatory requirements listed above.

4.3.3.3 Whole-House Fan Ventilation Cooling

A whole-house fan (WHF) is not a mandatory requirement. It is required in some climate zones when using prescriptive compliance. The three performance compliance options are the following:

1. No WHF is assumed in the performance compliance software (no ventilation cooling). This will be either energy-neutral, or there will be an energy penalty if the applicable climate zone assumes the effects of a WHF.
2. A default WHF means this proposed feature is equivalent to the standard feature used to establish the energy budget of the building (The performance of the fan is derated to account for deficiencies from installing undersized or inefficiently designed WHF).
3. The HERS-verified WHF option allows for modeling the effects of the WHF without derating the system performance. The HERS-verified option also allows modeling a WHF with a higher airflow rate or lower fan efficacy than the default, which improves the compliance credit.

4.3.3.4 Central Fan Ventilation Cooling

Central fan ventilation cooling (CFVC) performs a function similar to a WHF using the central space-conditioning ducts to distribute outside air. When using the performance compliance approach, a CFVC system may be selected in the compliance software instead of a conventional whole-house fan. Three compliance options are:

1. No CFVC is assumed in the performance compliance software (no ventilation cooling). This will be either energy-neutral, or an energy penalty will be assessed if the applicable climate zone assumes the effects of a WHF.
2. A default CFVC system means the proposed system is equivalent in size and features to a derated WHF.
3. The HERS verified CFVC system option allows for the effects of the system without derating system performance. It also allows for modeling a system with greater capacity, a higher airflow rate or lower fan efficacy than default.

After installation, the contractor must test the actual fan power and airflow of the system using the procedure in *Reference Residential Appendix RA3.3*, and show that it is equal or better than what was proposed in the compliance software analysis.

Field verification by a HERS Rater is required. (See Reference Residential Appendix RA3.3.)

4.4 Air Distribution System Ducts, Plenums, Fans, and Filters

Air distribution system performance can have a big effect on overall HVAC system efficiency. Therefore, air distribution systems are required to meet several mandatory and prescriptive requirements as discussed below.

The *2019 Energy Standards* specify mandatory requirements for air distribution ducts to be sealed and tested in all climate zones. There are also several compliance credits available related to duct system design.

Duct efficiency is affected by the following parameters:

1. Duct location (attic, crawlspace, basement, inside conditioned space, or other)
2. Specific conditions in the unconditioned space, for example, presence of a radiant barrier
3. Duct insulation characteristics
4. Duct surface area
5. Air leakage of the duct system

In performance calculations, duct efficiency can be calculated in one of two ways:

1. Default input assumptions
2. Diagnostic measurement values

The computer program will use default assumptions for the proposed design when the user does not intend to make improvements in duct efficiency.

4.4.1 Mandatory Measures for Air Distribution System Ducts, Plenums, Fans, and Filters

4.4.1.1 Minimum Insulation

§150.0(m)1

Ducts that are installed entirely in conditioned space must have an R-value of R-4.2, except for some portions of a duct system in wall cavities inside the thermal envelope, or in directly conditioned space (see Exceptions 1 and 2 to Section 150.0(m)1). In all other cases, the minimum allowed duct insulation value is R-6. Higher values may be required by the prescriptive requirements, as described below.

To determine whether ducts are entirely in conditioned space as defined in §100.1, a rater must field verify by visual inspection and by using the protocols of RA 3.1.4.3.8.

RA 3.1.4.3.8 describes the duct leakage to outside test that determines whether the ducts are within the pressure boundary of the space being served by the duct system. Also, a basic visual inspection of the ducts is required to ensure that no portion of the duct system is obviously outside the apparent pressure/thermal boundary.

Leakage to “outside” means conditioned air leaking from the ducts to anywhere outside the pressure boundary of the dwelling unit conditioned space served by the duct system, which includes leakage to outside the building, and leakage to adjacent dwelling units.

Exception to §150.0(m)1: Ducts and fans integral to a wood heater or fireplace are exempt from §150.0(m)1.

§150.0(m)5

For determining the installed R-value of duct insulation based on thickness, when not an integral part of a manufacturer-labeled, insulated duct product such as vinyl flex duct, the following shall be used:

1. For duct wrap, the installed thickness of insulation must be assumed to be 75 percent of the nominal thickness due to compression.
2. For duct board, duct liner, and factory-made rigid ducts not normally subjected to compression, the nominal insulation thickness shall be used.

4.4.1.2 Connections and Closures

§150.0(m)1 - §150.0(m)3

The Energy Standards set a number of mandatory measures related to duct connections and closures. These measures address the materials and methods used for duct sealing. The following is a summary. Refer to the sections of the Energy Standards listed above for details.

4.4.1.3 Factory-Fabricated Duct Systems

Factory-fabricated duct systems must comply with the following requirements:

1. All factory-fabricated duct systems must comply with UL 181 for ducts and closure systems, including collars, connections, and splices, and be labeled as complying with UL 181.
2. All pressure-sensitive tapes, heat-activated tapes, and mastics used in the manufacture of rigid fiberglass ducts must comply with UL 181 and UL 181A.
3. All pressure-sensitive tapes and mastics used with flexible ducts must comply with UL 181 and UL 181B.
4. Joints and seams of duct systems and related components cannot be sealed with cloth-backed rubber adhesive duct tapes unless such tape is used in combination with mastic and draw bands, or
5. It has on its backing the phrase "CEC approved," a drawing of a fitting to plenum joint in a red circle with a slash through it (the international symbol of prohibition), and a statement that it cannot be used to seal fittings to plenums and junction box joints.

4.4.1.4 Field-Fabricated Duct Systems

Field-fabricated duct systems must comply with the following requirements:

1. Factory-made rigid fiberglass and flexible ducts for field-fabricated duct systems must comply with UL 181. All pressure-sensitive tapes, mastics, aerosol sealants, or other closure systems used for installing field-fabricated duct systems shall meet the applicable requirements of UL 181, UL 181A, and UL 181B.
2. Mastic sealants and mesh:
 - a. Sealants must comply with the applicable requirements of UL 181, UL 181A, and/or UL 181B and be nontoxic and water-resistant.
 - b. Sealants for interior applications must be tested in accordance with ASTM C731 and D2202.
 - c. Sealants for exterior applications must be tested in accordance with ASTM C731, C732, and D 2202.
 - d. Sealants and meshes must be rated for exterior use.
3. Pressure-sensitive tapes must comply with the applicable requirements of UL 181, UL 181A, and UL 181B.
4. Joints and seams of duct systems and their components must not be sealed with cloth-backed rubber adhesive duct tapes unless such tape is used in combination with mastic and draw bands, or
5. It has on its backing the phrase "CEC approved," a drawing of a fitting to plenum joint in a red circle with a slash through it (the international symbol of prohibition), and a statement that it cannot be used to seal fittings to plenums or junction box joints.

4.4.1.5 Draw Bands Used With Flexible Duct

1. Draw bands must be either stainless-steel worm-drive hose clamps or UV-resistant nylon duct ties.
2. Draw bands must have a minimum tensile strength rating of 150 pounds.
3. Draw bands must be tightened as recommended by the manufacturer with an adjustable tensioning tool.

4.4.1.6 Aerosol-Sealant Closures

1. Aerosol sealants shall meet the requirements of UL 723 and be applied according to manufacturer specifications.
2. Tapes or mastics used in combination with aerosol sealing shall meet the requirements of this section.

If mastic or tape is used to seal openings greater than 1/4 inch, the combination of mastic and either mesh or tape must be used.

Building spaces such as cavities between walls, support platforms for air handlers, and plenums defined or constructed with materials other than sealed sheet metal, duct board, or flexible duct must not be used for conveying conditioned air, including return air and supply air. Using drywall materials as the interior surface of a return plenum is not allowed. Building cavities and support platforms may contain ducts. Ducts installed in cavities and support platforms must not be compressed to cause reductions in the cross-sectional area of the ducts. Although a HERS Rater may examine this as a part of his or her responsibilities when involved in a project, the enforcement of these minimum standards for ducts is the responsibility of the building official.

§150.0(m)2D, §150.0(m)3D

Duct systems may not use cloth-backed, rubber-adhesive duct tape (typical, “old fashioned,” nonrated duct tape) unless it is installed in combination with mastic and draw bands. Mastic and drawbands alone are adequate for sealing most connections. Cloth-backed, rubber-adhesive duct tape may be used to hold the outer vapor barrier in place or for some purpose other than prevention of duct leakage. Cloth-backed rubber adhesive duct tape alone is not adequate to serve as an air-sealing method or as a mechanical connection.

The enforcement of these minimum standards is normally the responsibility of the building official; however, HERS Raters will also verify compliance with this requirement in conjunction with duct leakage verification.

4.4.1.7 Product Markings

§150.0(m)2A, §150.0(m)6

All factory-fabricated duct systems must meet UL 181 for ducts and closure systems and be labeled as complying with UL 181. Collars, connections, and splices are considered to be factory-fabricated duct systems and must meet the same requirement.

Insulated flexible duct products installed to meet this requirement must include labels, in maximum intervals of 3 ft, showing the R-value for the duct insulation (excluding air films, vapor barriers, or other duct components), based on the tests and thickness specified in §150.0(m)4 and §150.0(m)5C.

4.4.1.8 Dampers to Prevent Air Leakage

§150.0(m)7

Fan systems that exhaust air from the building to the outside must be provided with back draft or automatic dampers.

§150.0(m)8

Gravity ventilating systems must have an automatic or readily accessible, manually operated damper in all openings to the outside, except combustion inlet and outlet

air openings and elevator shaft vents. This includes clothes dryer exhaust vents when installed in conditioned space.

4.4.1.9 Protection of Insulation

§150.0(m)9

Insulation must be protected from damage, including damage from sunlight, moisture, equipment maintenance, and wind, but not limited to the following:

1. Insulation exposed to weather must be suitable for outdoor service – for example, protected by aluminum, sheet metal, painted canvas, or plastic cover.
2. Cellular foam insulation shall be protected as above or painted with a coating that is water-retardant and shields from solar radiation that can degrade the material.

4.4.1.10 Ducts in Concrete Slab

Ducts in a concrete slab must have R-6 insulation, but other issues will come into play. If ducts are in the soil beneath the slab or embedded in the slab, the insulation material should be designed and rated for such installation. Insulation installed in below-grade applications should resist moisture penetration. (Closed-cell foam is one moisture-resistant product.) Common premanufactured duct systems are not suitable for below-grade installations. If concrete is to be poured directly over the ducts, then the duct construction and insulation system should be sturdy enough to resist the pressure and not collapse. Insulation should be of a type that will not compress, or it should be inside a rigid duct enclosure. The only time that common flex ducts are suitable in a below-grade application is when a channel is provided in the slab.

4.4.1.11 Porous Inner Core Flex Duct

§150(m)10

Over time, the outer vapor barrier of flex duct can degrade and be easily damaged. Therefore, porous inner core flex duct must have a non-porous layer or air barrier between the inner core and the outer vapor barrier.

4.4.1.12 Duct System Sealing and Leakage Testing

§150(m)11

Duct system sealing and leakage testing is mandatory in all climate zones. Duct systems in newly constructed single-family dwellings, townhouses, and multifamily dwellings are required to comply with the requirements. For single-family dwellings and townhouses where the air-handling unit is installed and ducts are connected directly to the air handler, the total leakage of the duct system must be 5 percent or less of the nominal system air handler airflow. For single-family dwellings and

townhouses inspected at the "rough-in" stage of construction, where the air-handling unit is not installed, the total leakage of the duct system shall not exceed 4 percent of the nominal systems air handler airflow.

For multifamily dwellings with the air-handling unit installed and the ducts connected directly to the air handler, the total leakage of the duct system shall not exceed 12 percent of the nominal system air handler airflow or the duct system leakage to outside shall not exceed 6 percent of the nominal system air handler airflow.

The duct system leakage must be verified according to the applicable procedures outlined in Reference Residential Appendix Section RA3.1.4.

Alterations and additions to ducted systems in existing buildings in all climate zones are also required to comply with applicable maximum leakage criteria. Refer to Chapter 9 for more information on duct sealing and leakage testing for existing buildings.

4.4.1.13 Duct Leakage Testing for Multiple Duct Systems With Common Return Ducts

If there are two or more duct systems in a building that are tied together at a common return duct, then each duct system should be tested separately, including the shared portion of the return duct system in each test. Under this scenario, the portions of the second duct system that is not being tested must be completely isolated from the portions of the ducts that are being tested, so the leakage from second duct system does not affect the leakage rate from the side that is being tested.

Figure 4-3 represents the systems that are attached to a shared return boot or remote return plenum. In this case, the point in the return system that needs to be blocked off is readily accessible through the return grille.

The "duct leakage averaging," where both systems are tested together as though it is one large system and divided by the combined tonnage to get the target leakage, may not be used as it allows a duct system with more the 5 percent leakage to pass if the leakage of the combined system is 5 percent or less.

Figure 4-3: Two Duct Systems With a Common Return Duct

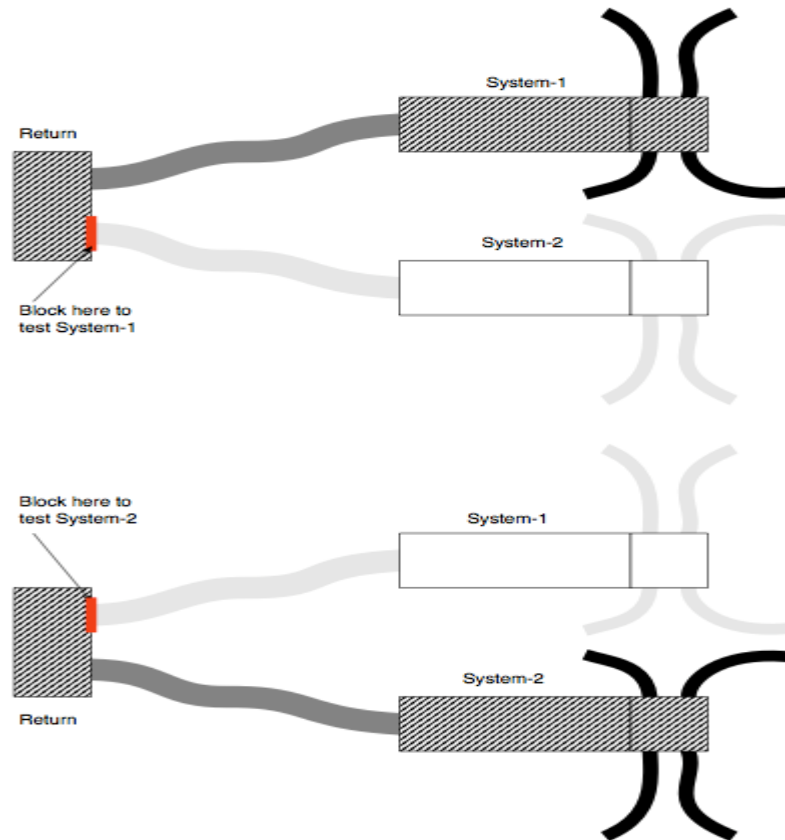

Source: California Energy Commission

4.4.1.14 Air Filtration

§150.0(m)12

Air filtration is used in forced air systems to protect the equipment from dust accumulation that could reduce the capacity or efficiency of the system. Preventing dust buildup may also prevent the system from becoming a host to biological contaminants such as mold, especially if dust is deposited on cooling coils that become wet from water condensation during comfort cooling operation. Air filter efficiencies of Minimum Efficiency Reporting Value (MERV) 6 to MERV 8 are sufficient for protection from these large airborne dust particles. Air filter efficiencies of at least MERV 13 are needed to protect occupants from exposure to the smaller airborne particles that are known to adversely affect respiratory health. These smaller particles are often referred to as PM 2.5 which refers to particulate matter of 2.5 microns. PM2.5 is produced from combustion such as that resulting from cooking in the kitchen and from exhaust from motor vehicles that enters a dwelling through ventilation openings and infiltration.

4.4.1.14.1 Air Filter Pressure Drop

Standards Section 150.0(m)12Bii requires all systems to be designed to accommodate the clean-filter pressure drop imposed by the system air filter device(s). This applies to space-conditioning systems and to the ventilation system types described in Section 4.4.1.14.2 below. The design airflow rate, and maximum allowable clean-filter pressure drop at the design airflow rate applicable to each air filter device shall be determined and posted on a sticker or label by the installer inside the filter grille or near the filter rack, according to Section 4.4.1.14.5 below.

Designers of space-conditioning systems must determine the total of the system external static pressure losses from filters, coils, ducts, and grilles, such that the sum is not greater than the available static pressure of the air handling unit at the design airflow rate. Therefore, air filters should be sized to minimize static pressure drop across the filter during system operation. The air filter pressure drop can be reduced by increasing the amount of air filter media surface area available to the system airflow. Increased media surface area can be accomplished by adjusting one, two, or all three of the following factors:

- a. Adjust the number of pleats of media per inch inside the air filter frame. The number of pleats per inch inside the filter frame is determined by the manufacturer's filter model design and is held constant for all filter sizes of the same manufacturer's model. For example, all 3M Filtrete 1900 filters will have the same media type, the same MERV rating, and the same number of pleats of media per inch inside the filter frame regardless of whether the nominal filter size is 20" X 30" or 24" X 24", and so forth. Generally, as the number of pleats per inch is increased, the pressure drop is reduced if all other factors remain constant. The pressure drop characteristics of air filters vary widely between air filter manufacturers and between air filter models, largely because of the number of pleats per inch in the manufacturer's air filter model design. System designers and system owners cannot change the manufacturer's filter model characteristics, but they can select a superior air filter model from a manufacturer that provides greater airflow at a lower pressure drop by comparing the filter pressure drop performance shown on the air filter manufacturer's product label (see example label in Figure 4-5).
- b. Adjust the face area of the air filter and filter grille. Face area is the nominal cross-sectional area of the air filter, perpendicular to the direction of the airflow through the filter. Face area is also the area of the filter grille opening in the ceiling or wall. The face area is determined by multiplying the length times width of the filter face (or filter grille opening). The nominal face area for a filter corresponds to the nominal face area of the filter grille in which the filter is installed. For example, a nominal 20" X 30" filter has a face area of 600 in² and would be installed in a nominal 20" X 30" filter grille. Generally, as the total system air filter face area increases, the pressure drop is reduced if all other factors remain constant. Total system air filter face area can be increased by specifying a larger area filter/grille, or by using

additional/multiple return filters/grilles, summing the face areas. The filter face area is specified by the system designer or installer.

- c. Adjust the depth of the filter and filter grille. Air filter depth is the nominal filter dimension parallel to the direction of the airflow through the filter. Nominal filter depths readily available for purchase include one, two, four, and six inches. Generally, as the system air filter depth increases, the pressure drop is reduced if all other factors remain constant. For example, increasing filter depth from one inch to two inch nominally doubles the filter media surface area without increasing the filter face area. The filter depth is specified by the system designer or installer.

4.4.1.14.2 Air Filter Particle Removal Efficiency Requirements – MERV 13

An air filter with a particle removal efficiency equal to or greater than MERV 13, or a particle size efficiency rating equal to or greater than 50 percent in the 0.30-1.0 μm range, and equal to or greater than 85 percent in the 1.0-3.0 μm range is required for the following systems:

- a. Mechanical space conditioning (heating or cooling) systems with a total of more than 10 feet of duct. The total is determined by summing the lengths of all the supply and return ducts for the forced-air system.
- b. Mechanical supply-only ventilation systems that provide outside air to an occupiable space.
- c. The supply side of mechanical balanced ventilation systems, including heat recovery ventilation systems and energy recovery ventilation systems that provide outside air to an occupiable space.

Evaporative coolers are exempt from the air filtration requirements

4.4.1.14.3 Air Filter Requirements for Space-Conditioning Systems:

Space-conditioning systems may use any of the three following compliance approaches:

- a. Install a filter grille or accessible filter rack that accommodates a minimum 2-inch depth filter, and install the appropriate filter.
- b. Install a filter grille or accessible filter rack that accommodates a minimum 1" depth filter, and install the appropriate filter. The filter/grille must be sized for a velocity of ≤ 150 ft per minute. The installed filter must be labeled to indicate the pressure drop across the filter at the design airflow rate for that return is ≤ 0.1 inch water column (w.c. [25 PA]).

Use the following method to calculate the 1" depth filter face area required. Divide the design airflow rate (ft^3/min) for the filter grille/rack by the maximum allowed face velocity 150 ft/min. This yields a value for the face area in ft^2 . Since air filters are sold using nominal sizes in terms of inches,

convert the face area to in² by multiplying the face area (ft²) by a conversion factor of 144 in²/ft². Summarizing:

$$\text{Filter Nominal Face Area (in}^2\text{)} = \text{airflow (CFM)} \div 150 \times 144$$

- c. Comply with Standards Tables 150.0-B and C (Table 4-10 and Table 4-11), which prescribe the minimum total system nominal filter face area and return duct size(s). The installed filter must be labeled to indicate the pressure drop across the filter at the design airflow rate for that return is \leq 0.1 inch w.c. (25 PA).. this option is an alternative to the Section 150.0(m)13 requirement for HERS-verified fan efficacy and airflow rate but requires instead a HERS verification of the return duct design.

4.4.1.14.4 Air Filter Requirements for Ventilation Systems

- a. Filters with a depth of 1" or greater are allowed.
- b. The design airflow rate, and maximum allowable clean-filter pressure drop at the design airflow rate applicable to each air filter device must be determined by the system designer or installer and that information must be posted on a sticker by the installer inside or near the filter grille/rack according to Section 4.4.1.14.5 below.
- c. Ventilation systems must deliver the volume of air specified by §150.0(o) with filters in place.

4.4.1.14.5 Filter Access and Filter Grille Sticker – Design Airflow and Pressure Drop

All filters used in all system types must be accessible to facilitate replacement.

- a. **Air filter grille sticker.** The design airflow rate, and maximum allowable clean-filter pressure drop at the design airflow rate applicable to each air filter grille/rack must be determined by the designer/installer, and posted on a sticker placed by the installer inside or near the filter grille/rack. The design airflow and initial resistance posted on this sticker should correspond to the conditions used in the system design calculations. This requirement applies to space conditioning systems and also to the ventilation system types described in Section 4.4.1.14.2 above.

An example of an air filter grille sticker showing the design airflow and pressure drop for the filter grille/rack is shown in Figure 4-4.

- b. **Air filter manufacturer label.** Space-conditioning system filters are required to be labeled by the manufacturer to indicate the pressure drop across the filter at several airflow rates. For the system to comply, and to ensure adequate airflow for efficient heating and cooling equipment operation, the manufacturer's air filter label (Figure 4-5) must display information that indicates the filter can meet the design airflow rate for

that return grille/rack at a pressure drop \leq the value shown on the installer's filter grille sticker (Figure 4-4). This requirement does not apply to the ventilation system types described in Section 4.4.1.14.2.

Figure 4-4: Example of Installer's Filter Grille Sticker

Air Filter Performance Requirement	Air Filter Performance Requirement	Maintenance Instructions
Airflow Rate (CFM) Must be greater than or equal to the value shown	Initial Resistance (IWC) Must be less than or equal to the value shown	Use only replacement filters that are rated to simultaneously meet both of the performance requirements specified on this sticker:
750	0.1	

Source: California Energy Commission

Figure 4-5: Example Manufacturer's Filter Label

MERV	(μ m)	0.30-1.0	1.0-3.0	3.0-10	Airflow Rate (CFM)	615	925	1230	1540	2085*	*Max Rated Airflow
13	PSE (%)	62	87	95	Initial Resistance (IWC)	0.07	0.13	0.18	0.25	0.38	

Source: California Energy Commission

4.4.1.14.6 Air Filter Selection

For a filter to meet the system specifications for airflow and pressure drop, it must be rated by the manufacturer to provide more than the specified airflow at less than the specified pressure drop. It is unlikely that a filter will be available that is rated to have the exact airflow and pressure drop ratings specified, so filters should be selected that are rated to have less than the specified pressure drop at the specified airflow rate, otherwise select filters that are rated to have greater than the specified airflow rate at the specified pressure drop. See Figure 4-4 for an example of an installer's filter grille sticker that provides an air filter rating specification for minimum airflow of 750 CFM at maximum pressure drop 0.1 inch w.c.

Manufacturers of air filters may make supplementary product information available to consumers that will assist with selecting the proper replacement filters. This product information may provide more detailed information about the filter model airflow and pressure drop performance – details such as airflow and pressure drop values that are intermediate values that lie between the values shown on their product label. The information may be published in tables, graphs, or presented in software applications available on the internet or at the point of sale.

Figure 4-6 below shows a graphical representation of the initial resistance (pressure drop) and airflow rate ordered pairs given on the example air filter manufacturer's label shown in Figure 4-5 above. The graph in Figure 4-6 makes it

possible to visually determine the airflow at 0.1 inch w.c. pressure drop for which the values are not shown on the manufacturer's filter label.

If there is no supplementary manufacturer information available, and it is necessary to determine the performance of a filter model at an airflow rate or pressure drop between two values shown on a manufacturer's label, linear interpolation may be used. Linear interpolation apps are readily available on the internet, and formulas for linear interpolation are shown below.

The linear interpolation method may be used to determine an unknown pressure drop corresponding to a known airflow rate by use of Equation 4-1a, or it may also be used to determine an unknown airflow rate corresponding to a known pressure drop by use of Equation 4-1b.

$$p = p_1 + [(f-f_1) \div (f_2-f_1)] \times (p_2 - p_1) \quad \text{Equation 4-1a}$$

where:

f = a known flow value between f_1 and f_2

p = the unknown pressure drop value corresponding to f.

p_1 and p_2 = known values that are less than and greater than p respectively.

f_1 and f_2 are the known values corresponding to p_1 and p_2 .

$$f = f_1 + [(p-p_1) \div (p_2-p_1)] \times (f_2 - f_1) \quad \text{Equation 4-1b}$$

where:

p = a known pressure drop value between p_1 and p_2

f = the unknown flow value corresponding to p.

f_1 and f_2 = known values that are less than and greater than f respectively.

p_1 and p_2 are the known values corresponding to f_1 and f_2 .

See Example 4-1 for sample calculations that determine the rated airflow of the filter corresponding to a known pressure drop specification (0.1 inch w.c.).

**Figure 4-6. Plot of Pressure drop vs. Airflow for a 20" X 30" X 1" Depth Air Filter
From Manufacturer Label Information**

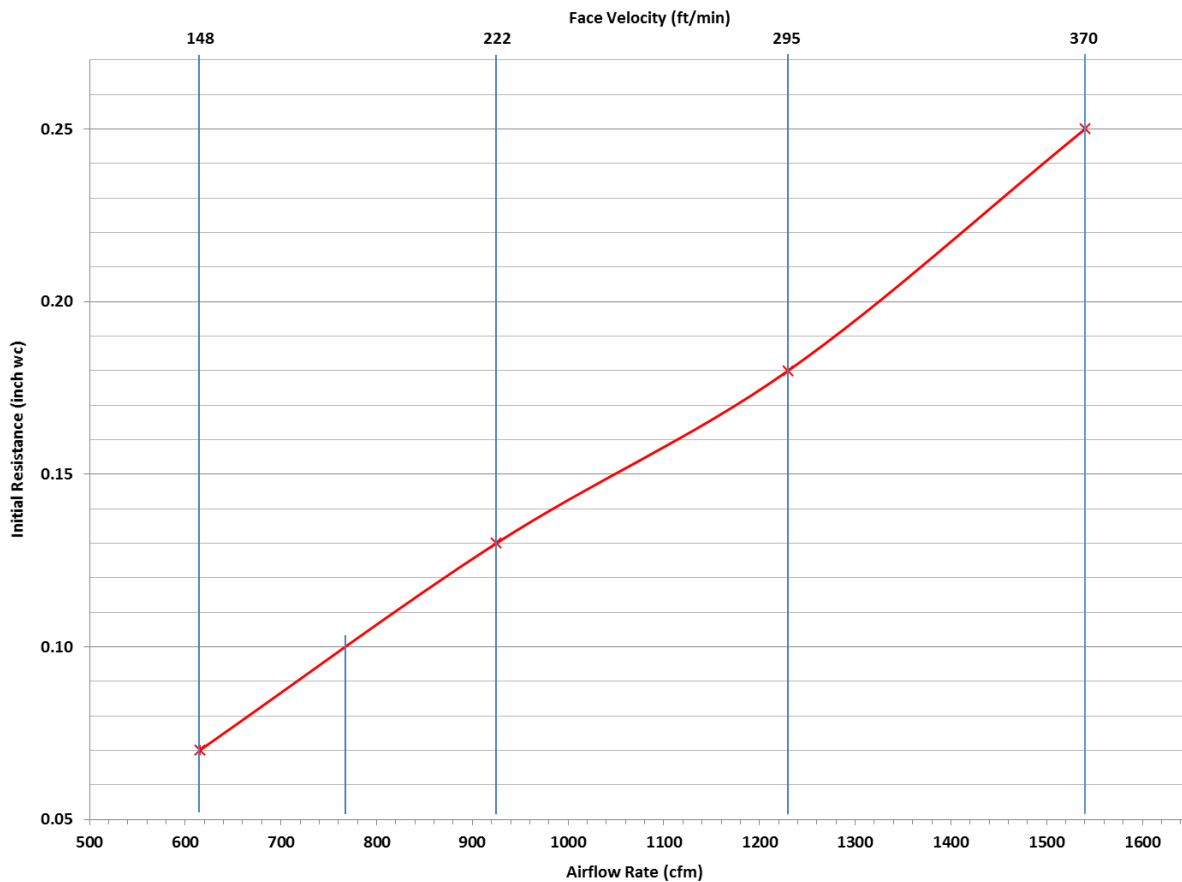

Source: California Energy Commission

Example 4-1– Filter Selection Using Linear Interpolation

Question:

Does the air filter label in Figure 4-5 indicate the filter would meet the airflow (750 CFM) and pressure drop (0.1 inch w.c) requirements shown on the installer filter grille sticker in Figure 4-4? How can I determine the filter's airflow rate at 0.1 inch w.c. for the manufacturer's filter label shown in Figure 4-5?

Answer:

The filter must be rated to provide greater than 750 CFM at the specified 0.1 inch w.c. pressure drop, or equivalently: the filter must be rated to provide a pressure drop less than 0.1 inch w.c at the specified 750 CFM.

Referring to Equation 4-1b, we calculate the unknown value "f" in CFM that corresponds to the known value "p" of 0.1 inch w.c..

Referring to Figure 4-5: $p_1=0.07$, $p_2=0.13$, $f_1=615$, $f_2=925$, and applying Equation 4-1b:

$615 + [(0.1-0.07) \div (0.13-0.07)] \times (925-615)$ yields 770 CFM

Therefore, since the filter is rated for greater than 750 CFM at 0.1 inch w.c, the filter complies.

Example 4-2– Filter Sizing

Question:

I am installing a 1,200 CFM furnace in a new house. It has a 20" x 20" x 1" inch filter rack furnished with a 1" depth filter installed in the unit. Is this filter in compliance?

Answer:

The nominal face area of the filter rack is 20" x 20" = 400 in², and since it is a 1" filter, the face area may not be less than 1,200 (CFM)/150x144 (in² / ft²) = 1,152 in². Therefore, this filter installation does not comply.

Example 4-3

Question:

For the same 1,200 CFM furnace, what other options do I have?

Answer:

Option 1: The filter will be in compliance if it has a depth of 2 inches or more, and is properly sized by the system designer such that the duct system as a whole will be capable of meeting the HERS verification for fan efficacy specified in Section 150.0(m)13.

Otherwise, the required total system filter face area of 1,152 in² must be met using multiple remote wall or ceiling filter grilles for which the sum of the face areas are equal to or greater than 1152 in², and the filters must be rated for pressure drop of 0.1 inch w.c. or less at the design airflow rates of each filter grille.

Option 2: Table 150.0-B may be used for compliance. If the air conditioner is rated at 3 tons and two return ducts sized at 16" and 14" or larger are provided, the total filter/grille nominal area may be reduced to 900 in², or 450 in² per filter grille. However, the filters still must have a pressure drop of 0.1 inch or less at 600 CFM (based on filter manufacturer label data).

For any filter, the pressure drop, efficiency, and length of time the filter can remain in operation without becoming fully loaded with dust, can all be improved by using filters that are deeper than 1". As the depth of the filter is increased, the pressure drop across the filter at the same face area will be greatly reduced.

Example 4-4**Question:**

I am installing a ductless split system in a space that is being added on to the house. Must I use the designated MERV 13 filter?

Answer:

No. The filtration requirements do not apply unless there is at least 10 feet of duct attached to the unit.

Example 4-5**Question:**

My customer has allergies and wants a MERV 16 or better filter. Is this in compliance?

Answer:

Yes. MERV rated filtration greater than MERV 13 meets (exceeds) the minimum particle removal efficiency requirement; thus, it may be used provided all other applicable requirements in Section 150.0(m)12 are complied with.

4.4.1.15 Forced-Air System Duct Sizing, Airflow Rate, and Fan Efficacy**§150.0(m)13**

Adequate airflow is critical for cooling equipment efficiency. Further, it is important to maintain adequate airflow without expending excessive fan power.

Section 150.0(m)13 requires system airflow and watt draw to be HERS-verified. See Reference Residential Appendices RA3.3 for the applicable HERS verification procedures.

Forced-air systems that provide cooling must comply with either the airflow rate and fan efficacy verification, or may comply with the return duct design specifications given in Tables 150.0-C and D.

1. Airflow and watt draw measurement and determination of fan efficacy:

When using the airflow (CFM/ton) and fan efficacy (watt/CFM) method, the following criteria must be met:

- a. Provide airflow through the return grilles that is equal to or greater than
 - 350 CFM per ton of nominal cooling capacity for systems that are not small-duct high-velocity systems.
 - 250 CFM per ton for small duct, high velocity systems.

Nominal cooling capacity. To determine the required airflow for compliance in CFM/ton, the nominal cooling capacity of the system in tons must be known.

The nominal cooling capacity system may be obtained from the manufacturer's product literature or from listings of certified product ratings from organizations such as AHRI, but the nominal capacity is usually shown in the unit model number on the manufacturer's nameplate attached to the outdoor condensing unit. A two- or three-digit section of the manufacturer's model number indicates the nominal capacity in thousands of BTU/hour. Given that there are 12,000 BTU/hour per ton of cooling capacity, you are likely to see something similar to one of the following number groupings in the model number: "018" which represents 1.5 Tons; "024," which represents 2 Tons; "030," which represents 2.5 Tons; "036," which represents 3 Tons; "042," which represents 3.5 Tons; "048," which represents 4 Tons; or "060," which represents 5 Tons.

- b. At the same time, the fan watt draw must be less than or equal to
- 0.45 watts per CFM for gas furnaces, or
 - 0.58 watts per CFM for air handling units that are not gas furnaces.
 - 0.62 watts per CFM for small duct, high velocity systems.

The methods for measuring the air-handling unit watt draw are described in Reference Residential Appendix RA3.3. Three acceptable apparatuses are:

- a. A portable watt meter,
- b. An analog utility revenue meter, or
- c. A digital utility revenue meter.

Note: When measuring fan watt draw in package air conditioners or heat pumps, it is recommended to use a portable true power clamp-on meter to provide flexibility for isolating the correct fan wires. These meters may need to be high-voltage-capable.

There are three acceptable methods for determining compliance with the system airflow requirement. They are described in Reference Residential Appendix RA3.3 and use one of the following:

- a. An active or passive flow capture hood to measure the total airflow through the return grill(s)
- b. Flow grid device(s) at the return grill(s) or other location where all the central fan airflow passes through the flow grid, or
- c. Fan flow meter device (also known as a duct blaster) to perform the plenum pressure matching procedure.

The flow grid and the fan flow meter methods both require access to static pressure measurements of the airflow exiting the cooling coil, which requires use of a HSPP or PSPP (Section RA3.3.1.1).

The contractor must install either a hole for the placement of a static pressure probe (HSPP) or provide a permanently installed static pressure probe (PSPP) as shown in Figure 4-5 below and Reference Residential Appendix RA3.3.

Figure 4-5: Location of the Static Pressure Probe

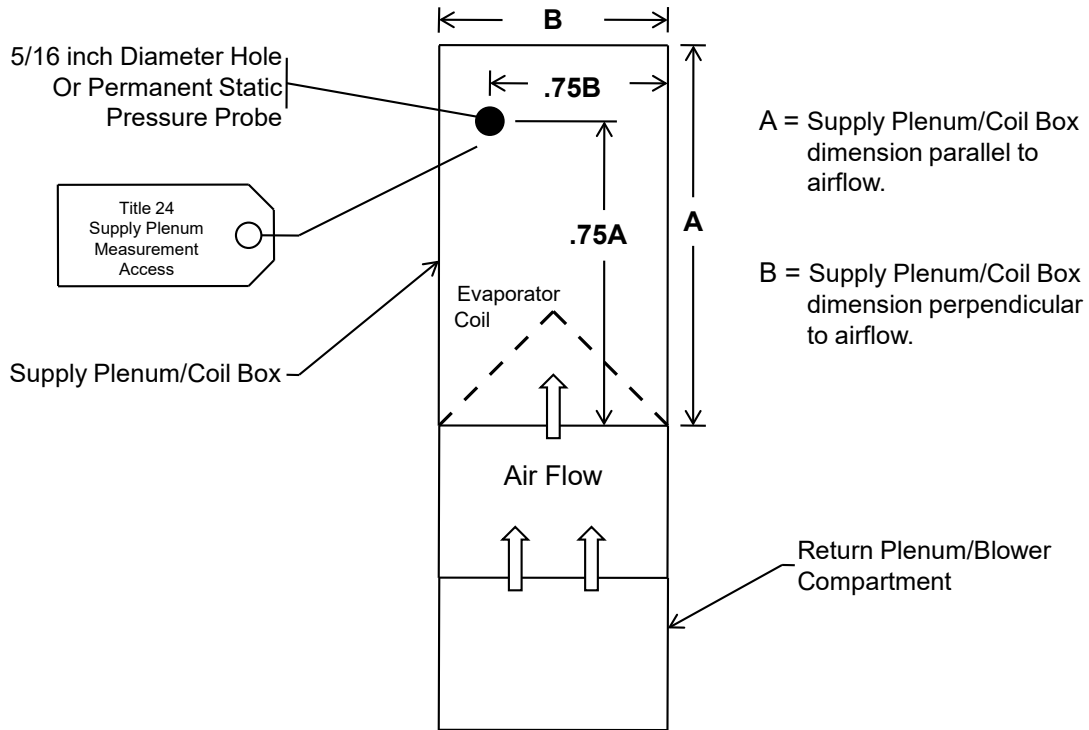

Source: California Energy Commission

The HSPP or PSPP simplifies cooling coil airflow measurement when using devices/procedures that depend on supply plenum pressure measurements.

2. Return Duct System Design Method – This method allows the designer to specify, and the contractor to install, a system that does not have to be tested for airflow and fan efficacy. This method can be used for systems with either one, or two return grilles. Each return shall not exceed 30 feet as measured from the return plenum to the filter grille. When bends are needed, sheet metal elbows are desirable. Each return can have up to 180 degrees of bend, and flex duct can have no more than 90 degrees of bend. To use this method, the designer and installer must provide return system sizing that meets the appropriate criteria in Standards Table 150.0-B and C, also shown in Table 4-10 or Table 4-11 below.

4.4.1.16 Airflow and Fan Efficacy Testing Versus Return Duct Sizing

Studies have shown that adequate airflow is critical to the efficient operation of air-conditioning systems. Section 150.0(m)13B, 13C, and 13D establish mandatory requirements that are intended to ensure adequate cooling airflow through properly sized ducts and efficient fan motors.

There are two options allowed to ensure adequate air flow. The first option is to design and install the systems using standard design criteria and then have the airflow and fan efficacy (AF/FE) of the system tested and third-party verified in the field. The second option is to size the return ducts according to Table 4-10 and Table 4-11 (as specified by EXCEPTION 1 to §150.0(m)13B and D).

The California Green Code and the California Mechanical Code require that residential duct systems be designed according to ACCA Manual D, or equivalent. If reasonable care and judgment are used while designing the duct system (both return and supply ducts), and the system is designed to reasonable parameters for airflow per ton, static pressure across the fan, and friction rate, these systems should have no problem passing the diagnostic tests.

The following design guidelines will increase the chances of the system passing the AF/FE testing:

1. Right-size the HVAC system; if a 3-ton unit is enough to satisfy the cooling load, do not install a 4-ton unit “just to be safe.” Oversizing equipment can cause comfort problems in addition to excessive energy use.
2. The HVAC designer must coordinate closely with the architect and structural engineer to make sure that the ducts will fit into the home as designed.
3. Prepare a detailed mechanical plan that can be followed in the field. If deviations must occur in the field, make sure that they are coordinated with the designer and that the design is adjusted as needed.
4. Follow Manual D for duct sizing:
 - a. Make sure that the correct duct type is being used (vinyl flex, sheet metal, rigid fiberglass, or other).
 - b. Make sure that all equivalent lengths and pressure drops are correctly accounted for (bends, plenum start collars, t-wyes, filters, grilles, registers, and so forth).
 - c. Select a furnace that will provide at least 400 CFM/ton at the desired static pressure of 125 to 150 Pa (0.5 to 0.6 inches w.c.).
 - d. Design the duct system to a static pressure across the fan of no more than 150 Pa (0.6 inches w.c.).
 - e. Consider upsizing the evaporator coil relative to the condenser to reduce the static pressure drop. This upsizing results in better airflow and slightly

better capacity and efficiency. Manufacturers commonly provide performance data for such condenser coil combinations.

- f. Consider specifying an air handler with a high efficiency (brushless permanent magnet) fan motor.
5. Install a large grill area and use a proper filter for the system.
6. Locate registers and equipment to make duct runs as short as possible.
7. Make all short-radius 90-degree bends out of rigid ducting.
8. Install flex duct properly by stretching all flex duct tight and cut off excess ducting, ensure the duct is not kinked or compressed, ensure flex duct is properly supported every 4 feet or less using 1inch strapping having less than 2 inches of sag between supports.

Consider using better quality supply and filter grilles. “Bar-type” registers have considerably better airflow performance than standard “stamped-face” registers. Refer to the manufacturer’s specifications and select accordingly.

Energy Standards Tables 150.0-B and C (Table 4-10 and Table 4-11) allow for only one or two returns. There may be times where three returns are necessary on a single system. Furthermore, Table 150.0-C does not allow for deviation from the two sizes specified. For example, the table requires two 16-inch return ducts for a 3.5-ton system, but specific airflow requirements and architectural constraints may dictate something more like a 20-inch and a 14-inch. In this situation, the designers would have to rely on standard engineering principles and trust that their design will pass the AF/FE diagnostic tests.

Having adequate room to run properly sized ducts has always been an issue. Historically, duct systems have been sized to fit into the home at the expense of proper airflow. The performance of these systems, in terms of efficiency and capacity, has suffered greatly because of this practice. These standards intend to change these practices. The home should be designed to accommodate properly sized ducts. This requires improved coordination among the architect, structural engineer, and mechanical designer earlier in the process.

Tables 150.0-B and C require the use of return grilles that are sized to achieve an optimal face velocity and static pressure drop. Tables 150.0-B and C also require the return grille devices to be labeled in accordance with the requirements in §150.0(m)12A to disclose the design airflow rate of the grille, and the maximum allowable clean-filter pressure drop for the air filter media as determined by the system design or applicable standards requirements. The nominal size of the air filter grille or air filter media should be used to calculate the return filter grille gross area for determining compliance with Tables 150.0-B and C. The nominal size of the filter grille is expected to be the same as the nominal size of the air filter media that is used in the grille and is most often the information used to identify these items for purchases. For example, a nominal 20-inch x 30-inch filter grille will use nominal 20-inch x 30-inch air filter media.

4.4.1.17 Return Duct Sizing Example

The mechanical contractor for a new home submitted the following mechanical design to the builder. It was designed using typical design specifications (400 CFM/ton at 125 Pa [0.5" w.c., friction rate = 0.1, etc.]). The system has a 4-ton condenser, and the air handler is rated for 1,600 CFM.

Figure 4-6: Return Duct Design Option 1

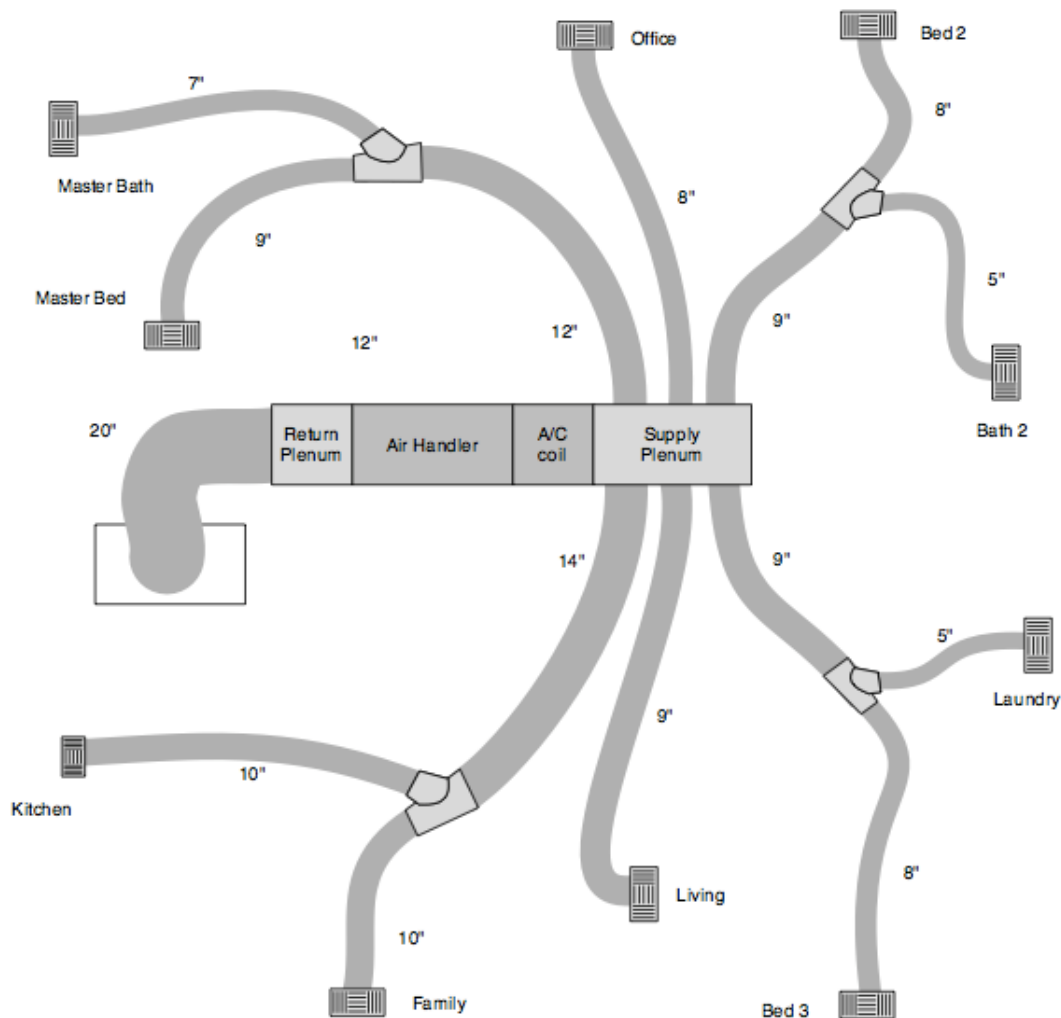

Source: California Energy Commission

Because the builder has specified a low-end air handler, he or she is concerned that the system may not pass the mandatory diagnostic testing requirement for airflow and fan efficacy. The builder requests that the system be redesigned with the return ducts sized according to Table 150.0-C. The following layout is the redesigned system (Figure 4-7). The only change is that the system now has two 18-inch return ducts and two filter grilles sized according to Table 150.0-C, rather than a 20-inch return duct and a filter grille. Because one of the return ducts had more than one 90-degree bend, one of the bends is required to be a metal elbow (to be insulated). The two return filters are 20-inch x 30-inch each and are rated by the manufacturer to show that they have a pressure drop of less than 125 Pa (0.1" w.c.) at 800 CFM each.

Figure 4-7: Return Duct Design Option 2

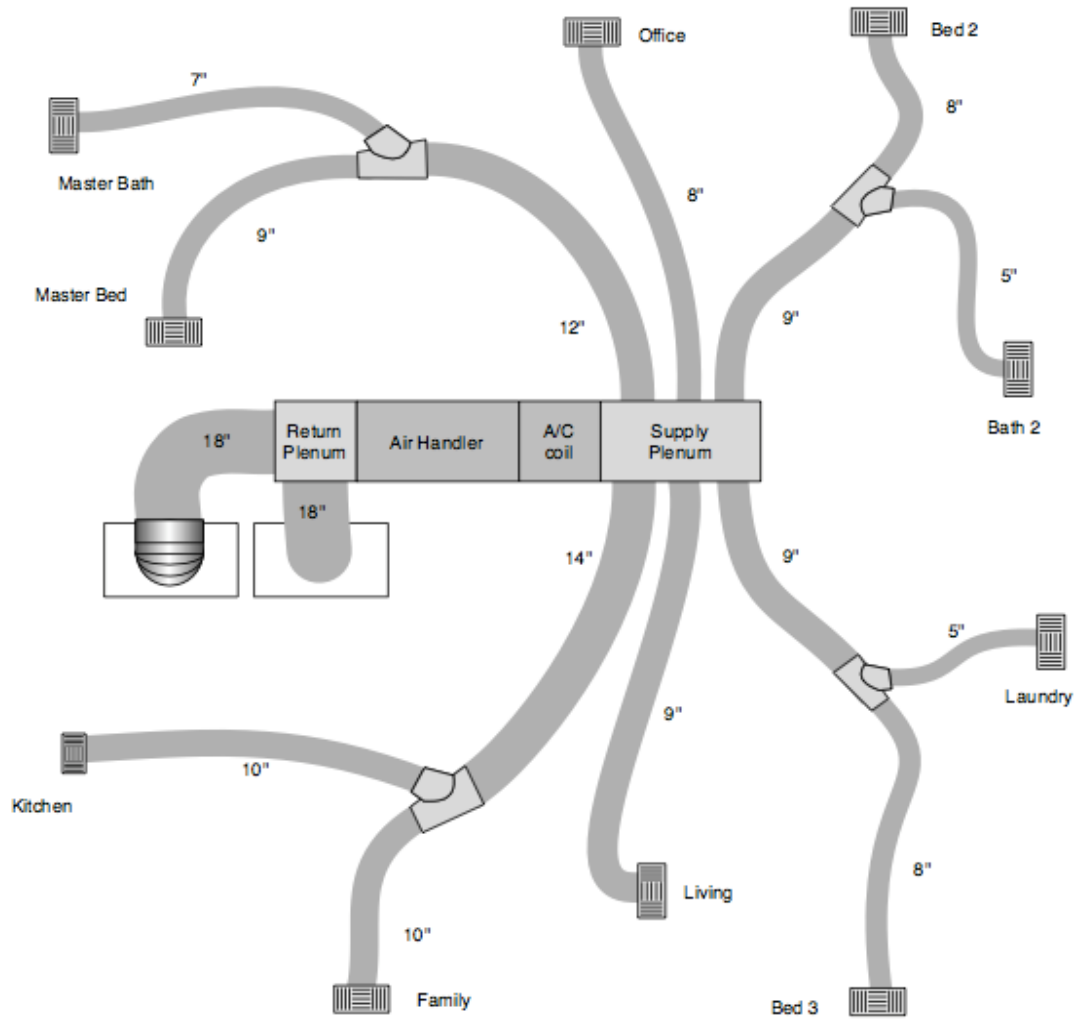

Source: California Energy Commission

Table 4-10: Return Duct Sizing for Single Return Duct Systems

System Nominal Cooling Capacity (Ton)	Minimum Return Duct Diameter (inch)	Minimum Total Return Filter Grille Gross Area (Inch ²)
1.5	16	500
2.0	18	600
2.5	20	800

From Table 150-B of the Energy Standards

Table 4-11: Return Duct Sizing for Multiple Return Duct Systems

Two Returns			
System Nominal Cooling Capacity (Ton)	Return Duct 1 Minimum Diameter (inch)	Return Duct 2 Minimum Diameter (inch)	Minimum Total Return Filter Grille Gross Area (inch².)
1.5	12	10	500
2.0	14	12	600
2.5	14	14	800
3.0	16	14	900
3.5	16	16	1000
4.0	18	18	1200
5.0	20	20	1500

From Table 150-C of the Energy Standards

4.4.1.18 Zonally Controlled Central Forced-Air Cooling Systems

The primary purpose of zoning ducted air conditioners, heat pumps, and furnaces is to improve comfort. Increased comfort is attained by having the capacity of the HVAC system (cooling or heating delivered) follow the shift in load as it changes across the house. For example, it is common for two-story homes to be too hot on the second floor in summer and winter. Zoning has the capability of diverting more of the HVAC capacity to the area with the increased load. Another common example is a home with a significant area of west-facing and east-facing windows. In the summer, the east rooms overheat in the morning, and the west rooms overheat in the afternoon.

Providing the most agreeable temperature to all the zones is comfortable, but it carries with it the possibility of increased energy consumption. Since the most common home is single-zoned and has only one thermostat placed near the center of the house, temperatures in the rooms distant from that thermostat will vary, sometimes significantly. If zoning is added, the more distant rooms may be conditioned to a more comfortable temperature. This increased conditioning requires more energy. When designed correctly, zoning allows only the zones that need conditioning to be conditioned, thus potentially saving energy.

It is common for single-speed zonally controlled central forced-air cooling systems to produce lower total system airflow through the returns when fewer than all zones are calling for conditioning. The reduced airflow lowers the sensible efficiency of single-stage heating or cooling equipment. Two primary causes of lower airflow in multiple zone dampered systems are:

1. Restriction of some system supply ducts by closing zoning dampers in zones that do not need additional cooling, while other zones do need cooling.
2. Recirculation of already-cooled air from the supply plenum directly back to the return plenum without first delivering the cooled air to the conditioned space by use of a bypass duct.

To prevent the lower efficiency that results from reduced system airflow or from recirculated bypass duct airflow, single-speed compressor zonally controlled central cooling systems must demonstrate they simultaneously meet mandatory fan efficacy and airflow requirements in all zonal control modes, which is possible only with a superior duct system design that does not restrict the system total airflow when fewer than all zones are calling for conditioning, and does not use a bypass duct. Section 150.1(c)13 prohibits use of bypass ducts prescriptively, but bypass ducts may be used if the efficiency penalty due to the reduced airflow through the return grille is modeled as described in Section 4.4.1.19 below.

Multispeed or variable-speed compressor-type zonally controlled cooling systems are not required to verify mandatory fan efficacy and airflow requirements in all zonal control modes; however, these systems must be HERS-verified to confirm they meet the mandatory fan efficacy and airflow requirements with the compressor on high speed and all zones calling for cooling.

4.4.1.19 Zonally Controlled Cooling Systems – Airflow and Fan Efficacy Requirements

Recent studies have shown that zonally controlled cooling systems with or without bypass dampers (multiple zones served by a single air handler with motorized zone dampers), usually do not meet the airflow and fan efficacy (AF/FE) requirements when fewer than all zones are calling. The energy penalty that results from this is greater than the benefit of having zonal control; therefore, zonal control is no longer simply assumed to be a “better-than-minimum” condition, and there are special compliance requirements for these systems.

Zonal control accomplished by using multiple single-zone systems is not subject to the requirements specified in Energy Standards Section 150.0(m)13C.

Two-speed and variable-speed compressors are considered multi-speed. Multispeed compressors allow the system capacity to vary to more closely match reduced cooling loads when fewer than all zones call for cooling. Therefore, an exception to Section 150.0(m)13C gives multispeed compressor systems special consideration when used in zoned systems and these systems are not required to verify performance in all zonal control modes. Instead, the airflow and fan efficacy testing is required to be performed only at the highest speed when all zones call for cooling. Zoned systems with single-speed compressors must be tested and pass in all operating modes.

An exception to Section 150.0(m)13C allows single speed compressor systems to comply with HERS verification of the *mandatory* AF/FE requirements only at the highest fan speed when all zones call for cooling, provided the system also uses the *performance* compliance approach and complies with HERS verification of the requirements for AF/FE in all zonal control modes specified by the software user input for minimum airflow rate when fewer than all zones call for cooling. Single-speed compressor systems, with or without bypass dampers, are less likely to meet the *mandatory* AF/FE requirements in Section 150.0(m)13C with fewer than all

zones calling for cooling; therefore, the performance compliance software calculates a penalty for the reduced airflow (specified by the user) during operation when fewer than all zones call for cooling. Other energy features for the building must offset this penalty for reduced airflow when fewer than all zones call for cooling. In the performance compliance software, if the system is modeled as a zoned system with a single-speed compressor, the minimum allowable airflow drops to 150 CFM/ton. But because the standard house is assumed to have an airflow of 350 CFM/ton, there is a penalty imposed on the compliance calculation unless the designer specifies a value of 350 or higher. Entering a value between 150 and 350 can lessen the penalty resulting from the minimum allowed value of 150 CFM/ton.

It is extremely important that the energy consultant model airflow and fan efficacy values that are reasonable and can be verified by a HERS Rater; otherwise, the system will fail HERS verification, and the compliance calculations will have to be revised to specify user input equivalent to the actual values that could pass HERS verification. Energy consultants should coordinate with the HVAC designer before registering the certificate of compliance.

Bypass dampers may be installed only if the certificate of compliance specifically states that the system was modeled as having a bypass damper.

Example:

1. A home is to be built with a heat pump connected to a zoned system (two zones) with a single-speed compressor and bypass ducts. From experience, the HVAC contractor knows that it will not be possible to meet the 350 CFM/ton requirement, but 275 CFM/ton is likely.
2. The energy consultant models the system in the proposed house with 275 CFM/ton and 0.45 W/CFM (value for a gas furnace). Because the standard house assumes 350 CFM/ton, there is an energy penalty that must be made up by including other better-than-standard features in the performance compliance input, but the penalty is not as large as it would be at a value of 150 CFM/ton.
3. 275 CFM/ton must be tested in all control modes.
4. The home is built, and the system is verified by a rater and passes at 287 CFM/ton with one zone calling, 298 CFM/ton with the other zone calling, and 372 CFM/ton with both zones calling. The system is also measured with all zones calling to confirm it meets or exceeds 350 CFM/ton.
5. If this same home was to be built with a multispeed compressor, it would be tested only with all zones calling, but the target airflow would be no less than the mandatory 350 CFM/ton. Compliance credit can be achieved by modeling airflows greater than the mandatory CFM/ton and/or fan efficacies less than the mandatory watts/CFM.

Table 4-12: Single-Zone Ducted Central Forced-Air Cooling Systems

Single-Zone Ducted Cooling Systems (Single Zone Off a Single Air Handler)			
Compressor Type	Mandatory Requirements for Airflow and Fan Efficacy	Performance Compliance Option	
		Proposed System Defaults	Modeled Airflow and Fan Efficacy
Single-Speed, Multispeed, or Variable-Speed: Testing Performed on Highest Speed only	Airflow: <ul style="list-style-type: none"> ≥ 350 CFM/ton if not a small duct high velocity type ≥ 250 CFM/ton if is a small duct high velocity (SDHV) type Fan Efficacy: <ul style="list-style-type: none"> ≤ 0.45 W/CFM for gas furnaces (GF) ≤ 0.58 W/CFM for air handlers that are not gas furnaces (non-GF) ≤ 0.62 W/CFM for SDHV type Exception: Airflow and Fan Efficacy HERS verification not required if return system meets Tables 150.0-B or C. However, HERS verification that return duct installation meets Tables 150.0-B or C is required	Airflow: <ul style="list-style-type: none"> 350 CFM/ton (non-SDHV) 250 CFM/ton (SDHV) Fan Efficacy: <ul style="list-style-type: none"> 0.45 W/CFM (GF) 0.58 W/CFM (non-GF) 0.62 W/CFM (SDHV) 	Airflow: <ul style="list-style-type: none"> ≥350 CFM/ton (non-SDHV) ≥250 CFM/ton (SDHV) and/or Fan Efficacy: <ul style="list-style-type: none"> ≤0.45 W/CFM (GF) ≤0.58 W/CFM (non GF) ≤0.62 W/CFM (SDHV)

Source: California Energy Commission

Table 4-13: Zonally Controlled Central Forced-Air Cooling Systems

Zoned Ducted Cooling Systems (Multiple Zones off a Single Air Handler)			
Compressor Type	Mandatory Requirements for Airflow and Fan Efficacy ¹	Performance Compliance ²	
		Proposed System Defaults ³	Modeled Airflow and Fan Efficacy
Single Speed	Airflow: <ul style="list-style-type: none"> ≥ 350 CFM/ton (non-SDHV) Fan Efficacy: <ul style="list-style-type: none"> ≤ 0.45 W/CFM (GF) ≤ 0.58 W/CFM (non-GF) For Prescriptive Compliance Method, verification is mandatory in all zonal control modes. When Performance Compliance Method is used, verification of the <i>mandatory</i> requirements are performed only at highest capacity operation with all zones calling, and the additional performance targets for W/CFM and CFM/ton specified by the user in the	Airflow: <ul style="list-style-type: none"> 150 CFM/ton Fan Efficacy: <ul style="list-style-type: none"> 0.45 W/CFM (GF) 0.58 W/CFM (non-GF) 	Airflow: <ul style="list-style-type: none"> ≥ 150 CFM/ton and/or Fan Efficacy: <ul style="list-style-type: none"> ≤ 0.45 W/CFM (GF) ≤ 0.58 W/CFM (non GF) Verification of modeled values required in all zonal control modes. The <i>mandatory</i> requirements for W/cfm and CFM/ton

	performance compliance software are required to be verified in all zonal control modes.		must also be verified at highest capacity operation with all zones calling
Multispeed or Variable Speed	<p>Airflow:</p> <ul style="list-style-type: none"> • ≥ 350 CFM/ton <p>Fan Efficacy:</p> <ul style="list-style-type: none"> • ≤ 0.45 W/CFM (GF) • ≤ 0.58 W/CFM (non-GF) <p>Verification is required at highest capacity operation and with all zones calling</p>	<p>Airflow:</p> <ul style="list-style-type: none"> • 350 CFM/ton <p>Fan Efficacy:</p> <ul style="list-style-type: none"> • 0.45 W/CFM (GF) • 0.58 W/CFM (non-GF) 	<p>Airflow</p> <p>≥ 350 CFM/ton</p> <p>and/or</p> <p>Fan Efficacy:</p> <ul style="list-style-type: none"> • ≤ 0.45 W/CFM (GF) • ≤ 0.58 W/CFM (non-GF) <p>Verification of modeled values required at highest capacity operation with all zones calling</p>
<p>¹ For the Prescriptive Compliance Method, all Mandatory Requirements for airflow and fan efficacy must be met, and use of a bypass duct is not allowed.</p> <p>² For the Performance Compliance Method, all Mandatory Requirements for airflow and fan efficacy must be met, and use of a bypass duct may be specified in the compliance software input for the zoned system type. Additionally, the requirements specified for performance compliance must be met</p> <p>³ The Standard Design value for all cases is 350 CFM/ton (all system types); 0.45 W/CFM (GF); 0.58 W/CFM (non-GF).</p>			

Source: California Energy Commission

4.4.1.20 Indoor Air Quality and Mechanical Ventilation

§150.0(o)

See Section 4.6 of this chapter for details.

4.4.2 Prescriptive Requirements for Air Distribution System Ducts, Plenums, and Fans

The 2019 Energy Standards are designed to offer flexibility to the builders and designers of residential new construction in terms of achieving the intended energy efficiency targets. As such, several options are offered for achieving one of two design objectives related to improving energy performance of homes built with ventilated attics in Climate Zones 4, and 8-16, as shown in Figure 4-8.

Figure 4-8: Ventiladed Attic Prescriptive Compliance Choices in Climate Zones 4, 8-16

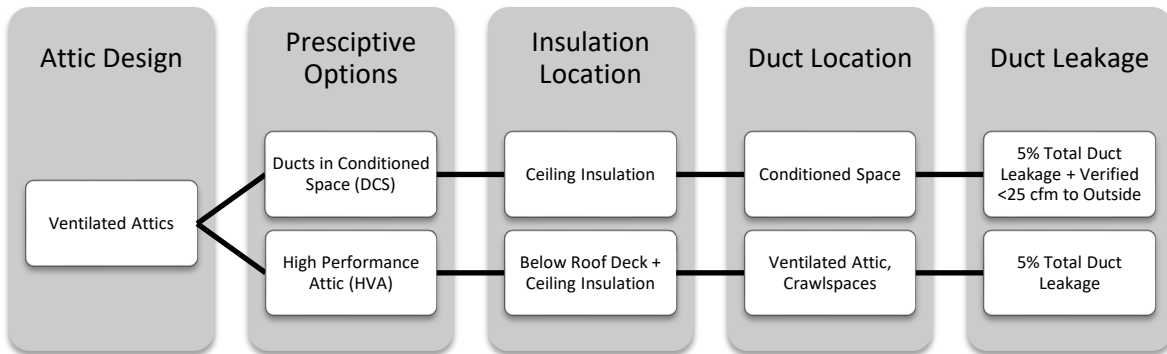

Source: California Energy Commission

A high-performance attic (HPA) implements measures that minimize temperature difference between the attic space and the conditioned air being transported through ductwork in the attic. The package consists of insulation below the roof in addition to insulation at the ceiling, R-8 ducts, and 5 percent total duct leakage of the nominal air handler airflow. These requirements and approaches to meet the requirements are explained in Section 3.5.3 of this manual.

Ducts in conditioned space (DCS) is achieved when the ducts and air handler(s) are within the thermal envelope and air barrier of the building. This DCS option requires field verification to meet the prescriptive requirement. The following sections describe the duct related requirements for DCS.

4.4.2.1 Duct Location

§150.1(c)9

Standard residential construction practice in California is to place ducts and associated air handling equipment in the attic. When meeting the prescriptive

requirements for the Energy Standards, there are two options for where this equipment can be located:

1. If meeting the prescriptive requirements of the high-performance attic (HPA) as explained above, the duct system and air handlers of HVAC systems are allowed to be located in the attic.
2. If meeting the prescriptive requirements of the ducts in conditioned space (DCS) as explained above, the duct system and air handlers of HVAC systems must be located in conditioned space, which includes a joist cavity between conditioned floors, or in a sealed cavity below attic insulation.

If the DCS requirements are to be met, additional requirements apply:

1. Air handlers containing a combustion component should be direct-vent (sealed combustion chambers), and shall not use air from conditioned space as combustion air. Other types of combustion heating systems are possible given the system installer adheres to the combustion air requirements found in Chapter 7 of the California Mechanical Code.
2. Duct location needs to be verified through a visual inspection per Reference Residential Appendix RA 3.1.4.1.3.
3. Duct leakage to outside needs to be confirmed by field verification and diagnostic testing in accordance with Reference Residential Appendix RA3.1.4.3.8.
4. Ducts are insulated to a level required in Table 150.1-A.

Figure 4-9: Checklist for Prescriptive Requirement – Option C DCS (§ 150.1(c)1)

<p>§150.1(c)1 Option C</p>
<p><input type="checkbox"/> Vented attic</p> <p><input type="checkbox"/> R30 or R38 ceiling insulation (climate zone specific)</p> <p><input type="checkbox"/> R6 ducts (climate zone specific)</p> <p><input type="checkbox"/> Radiant Barrier</p> <p><input type="checkbox"/> Verified ducts in conditioned space</p>

Source: California Energy Commission

The checklist in Figure 4-9 lists all the requirements for complying prescriptively using DCS strategy. It is not enough to locate ducts in conditioned space, the insulation must also meet prescriptive values. If a building is not able to meet all of the requirements in this checklist, it must use the performance approach or Option B from Section 150.1(c).1. Refer to Section 3.5 of the *Residential Compliance Manual* for more information on these options.

There are several methods of achieving the goal of DCS. The basic information of the strategies, related benefits, challenges, and potential solutions to those challenges are outlined below.

A. Vented Attic, Dropped Ceiling

This strategy places ducts within the thermal envelope without affecting the standard construction of the attic space. This strategy works well in linear plans where rooms branch out from a central hallway with the dropped ceiling.

Figure 4-10: Ducts in Conditioned Space Using a Dropped Ceiling

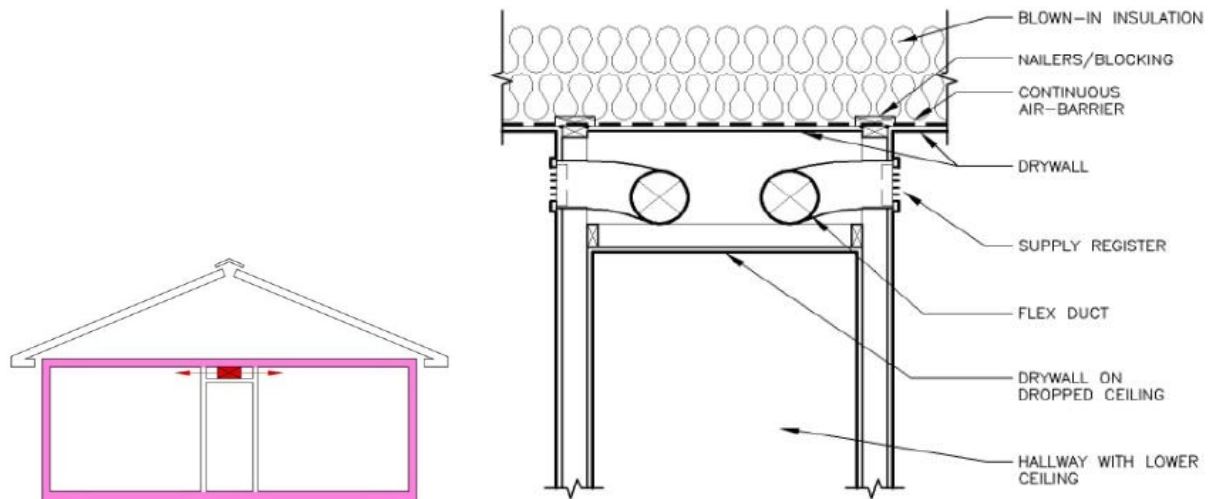

Source: www.ductsinside.org/

Figure 4-11: Ducts Routed Through a Dropped Ceiling



Source: BIRA Energy

Benefits of selecting this strategy include the following:

1. Attic ventilation remains the same as standard practice.
2. This strategy does not affect attic assembly or insulation; there are no changes to truss design.
3. The strategy works with simple and linear designs with rooms off the main hallway but can work with more complex plans.
4. The strategy can be integrated into architectural accents.

There are challenges associated with this strategy as outlined below, but they can be overcome with good design and installation practices.

1. Need to address air handler location – there may not be sufficient space (height, width) in the dropped ceiling to accommodate the air handler. In this case, the air handler would need to be installed in a separate closet within the thermal boundary of the home.
2. Coordination needed between trades – moving the ducts and air handlers and the need to isolate and seal the dropped ceiling would necessitate coordination between different trades (HVAC installer, drywall, framing, and electrical contractors) to ensure thermal integrity of the dropped ceiling.

B. Vented Attic, Conditioned Plenum Space

A conditioned plenum is created when a space within the attic is sealed off and insulated from the rest of the attic. To use this design option, a builder can specify two types of modified trusses: either scissor trusses or a truss configuration that creates a plenum box. Another way to create a conditioned plenum does not involve modified trusses, but rather to create the space by framing, sealing and insulating the plenum space above the ceiling plane.

Figure 4-12: Plenum Truss Design Example

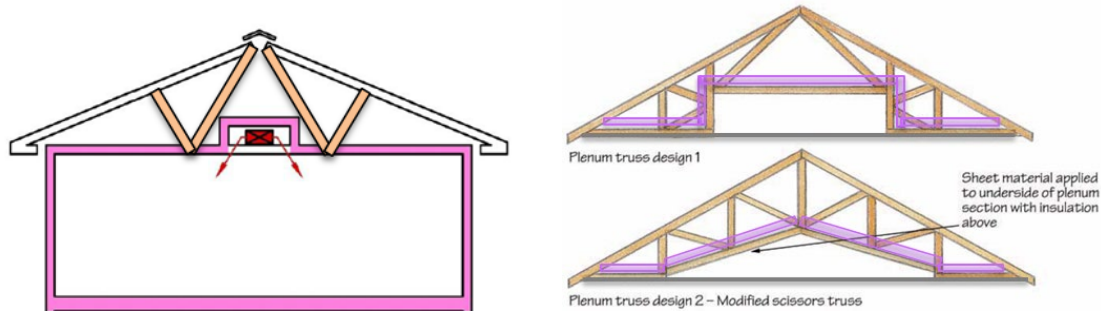

Source: www.ductsinside.org

Similar to a dropped ceiling, this design is easier with a linear plan that allows the conditioned space in the attic to cover a central “spine” throughout the floor plan that can reach all spaces in need of supply registers. This design option allows for ducts in the attic space and does not affect aesthetics of the home.

Benefits for selecting the strategy:

1. Vented attic space, same as standard construction
2. Aesthetically less disruptive than dropped ceiling
3. Works with simple and linear designs with rooms off main hallway

There are challenges associated with this strategy as outlined below, but they can be overcome with good design and installation practices.

1. Need to seal the plenum from attic – as with most of the DCS strategies, it is important that care and attention are provided to air-sealing the plenum space from the attic space.
2. May require modified trusses, in which case manufacturers need to be provided with specifications that can be met.

C. Vented Attic, Open Web Floor Truss

Figure 4-13: Open Web Floor Truss Example

Source: www.ductsinside.org

This option can work for two-story construction and makes use of the space between floors to house ducts. Open-web floor trusses are uncommon in residential construction but are available from several floor joist manufacturers. The depth of floor joists may need to be increased to create a large enough space for supply ducts. The increased joist depth may affect interior details and wall heights. Because of the size constraints from using the floor truss, there is a need to preserve construction quality and prevent undesirable construction practices such as forcing 14-inch ducts into 12-inch joist spaces. Another option is to use alternatives to wire helix plastic flexible ducts that take up less space. Coordination between the architect and the HVAC engineer and/or contractor is needed to ensure that ducts are correctly sized and truss depths are appropriately selected. Using the area between floors to house ducts prescribes that supply registers be at the floor or lower wall in the second story and the ceiling or upper wall in the first story.

D. Mechanical Closet and Placement of Sealed Combustion Furnace

Figure 4-14: Mechanical Closet Placement Example



Source: IBACOS 2013

As part of the requirement for moving the duct system and air handler into a conditioned space, construction of a mechanical closet is necessary with some DCS strategies. For example, if ducts are placed in dropped ceiling space but there is not enough room to accommodate the air handler in that space, the mechanical closet could be placed inside the thermal boundary of the building. A conditioned plenum could provide enough space for ducts and equipment; therefore, a mechanical closet may not be needed.

One potential location for a mechanical closet is within the garage or other spaces normally not conditioned. In such instances, the air handler must be located within a specially built closet that is insulated to the same level as the exterior of the house so that the closet is not a part of the unconditioned space. Combustion air for the air handler must be taken directly from the outside through a direct vent to the outside.

4.4.2.2 Duct Insulation

§150.1(c)9

All ducts shall be insulated to a minimum installed level as specified by Table 150.1-A, which requires either R-6 or R-8 depending on the climate zone and whether Option B or Option C is chosen for roof/ceiling Insulation. Since R-6 is the mandatory minimum for ducts in unconditioned space and R-4.2 for ducts located entirely in conditioned space as verified by a HERS Rater, the prescriptive duct insulation requirement can be opted out by using the performance approach and trading off the energy penalty against some other features.

4.4.2.3 Central Fan-Integrated (CFI) Ventilation

There is a prescriptive requirement for ducted systems that have cooling and a CFI ventilation system to have the fan efficacy verified. This can be opted out using the performance approach.

Figure 4-15: R-4.2, R-6, and R-8 Ducts

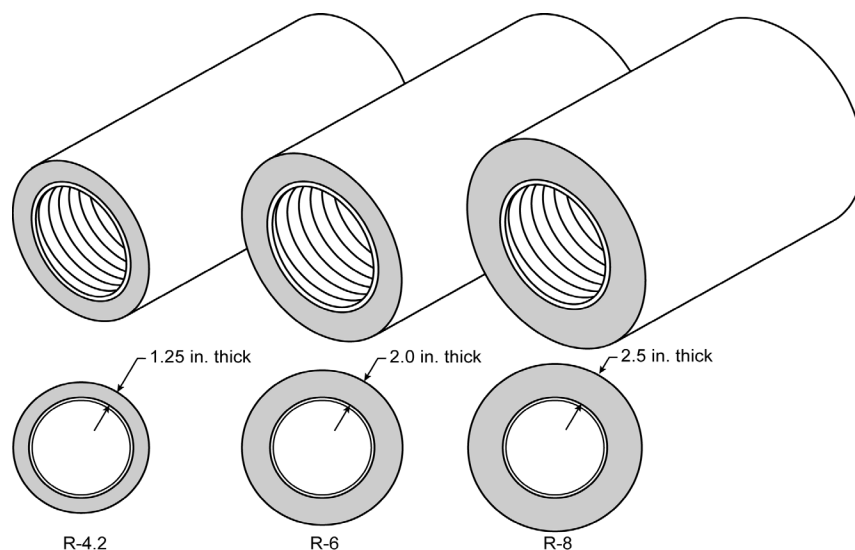

Source: California Energy Commission

4.4.3 Compliance Options for Air Distribution System Ducts, Plenums, and Fans

The Energy Standards provide credit for several compliance options related to duct design and construction.

4.4.3.1 System Airflow and Fan Efficacy

A performance compliance credit is available for HERS verification of the installation of a high-efficiency air handler and duct system that performs better than the applicable mandatory requirements for minimum system airflow (CFM/ton) and maximum system fan efficacy (W/CFM). The performance compliance method allows the user's proposed airflow and fan efficacy to be entered into the program, and credit will be earned if the airflow is greater than the minimum required, and fan efficacy is lower than the default. After installation, the contractor must test the actual fan efficacy of each system using the procedure in *Reference Residential Appendix RA3.3* and show that it is equal or less than what was proposed in the compliance software analysis.

The fan efficacy and airflow must also be verified by a HERS Rater.

4.4.3.2 Duct Location

There are three ways to achieve credit for favorable duct location when using the performance compliance method:

1. Credit is available if no more than 12 linear feet (LF) of duct are outside the conditioned space and the user chooses the high-performance attic (HPA) as explained in Section 3.5.3. This total must include the air handler and plenum lengths. This credit results in a reduction of duct surface area in the computer compliance programs. This option requires certification by the installer and field verification by a HERS Rater.
2. The second alternative applies when 100 percent of the ducts are located in conditioned space and the user chooses high-performance attic (HPA) as explained in Section 3.5.3. This credit results in eliminating the conduction losses associated with the return and supply ducts; however, leakage rates still apply. This option requires field verification of the duct system by means of a visual inspection by a HERS Rater.
3. Credit for a high-efficiency duct design is available. This option requires field verification of the duct design layout drawing(s) by a HERS rater. Verified duct design, when required, will be included in the HERS Required Verification list on the certificate of compliance (CF-1R). This approach provides energy savings credits for having shorter duct runs, fewer ducts, ducts in beneficial locations of ductwork, and other benefits of a well-designed duct system. This credit is available regardless of whether a high-performance attic (HPA) or ducts in conditioned space (DCS) option is chosen, as explained in Section 3.5.3.

There is no compliance credit provided for choosing a heating system such as a wall furnace, floor heater, or room heater, even though those systems typically have no ducts. For these cases, the standard design in the compliance calculation uses the same type of system and has no ducts. However, other systems, such as hydronic heating systems with a central heater or boiler and multiple terminal units, are considered central HVAC systems that are compared to a ducted system in the standard design. If the hydronic system has no ducts, there may be a significant energy credit through the performance method.

4.4.3.3 Duct Insulation

Performance credit is also available if all the ducts are insulated to a level higher than required by the prescriptive package. If ducts with multiple R-values are installed, the lowest duct R-value must be used for the entire duct system. However, the air handler, plenum, connectors, and boots can be insulated to the mandatory minimum R-value.

As an alternative when there is a mix of duct insulation R-values, credit is available through the method described in the next section.

4.4.3.4 Diagnostic Duct Location, Surface Area, and R-value

This compliance option allows the designer to take credit for a high-efficiency duct design that incorporates duct system features that may not meet the criteria for the duct location and/or insulation compliance options described above. This method requires that the designer must enter the design characteristics of all ducts that are not within the conditioned space. The information required for the input to the compliance software includes the length, diameter, insulation R-value, and location of all ducts. This method will result in a credit if the proposed duct system is better than the standard design.

To claim this credit, the duct system design must be documented on plans that are submitted to the enforcement agency and posted at the construction site for use by the installers, the enforcement agency field inspector, and the HERS Rater. The duct system must be installed in accordance with the approved duct system plans, and the duct system installation must be certified by the installer on the CF2R form and verified by a HERS Rater on the CF3R form. Details of this compliance option are described in the *Residential ACM Reference Manual*, and verification procedures are described in RA3.1 of the Reference Residential Appendix.

4.4.3.5 Buried and Deeply Buried Ducts

This compliance option allows credit for the special case of ducts that are buried by blown attic insulation. For ducts that are within 3.5 inches of the ceiling, the effective R-value is calculated based on the duct size and R-value, depth of ceiling insulation, and type of blown insulation (fiberglass or cellulose) as shown in Tables 16, 17, and 18 in the *Residential ACM Reference Manual*. The user-entered duct system can be any combination of unburied, buried, and deeply buried duct runs. The software will determine the overall duct system effective R-value by weight averaging the user entered duct system.

Ducts must have a minimum insulation level prior to burial, R-6 for new ducts and R-4.2 for existing. This case is referred to as “Buried Ducts on the Ceiling.” Additional credit is available for “Deeply Buried Ducts,” which, in addition to the requirements for “Buried Ducts on the Ceiling,” are ducts completely covered by at least 3.5 inches of attic insulation. Deeply buried ducts must be enclosed in a lowered portion of the ceiling or buried by use of a durable containment system (e.g. gypsum board, plywood, etc.), or buried under a uniform level of insulation that achieves the 3.5-inch burial level.

Figure 4-16: Buried Ducts on Ceiling and Deeply Buried Ducts

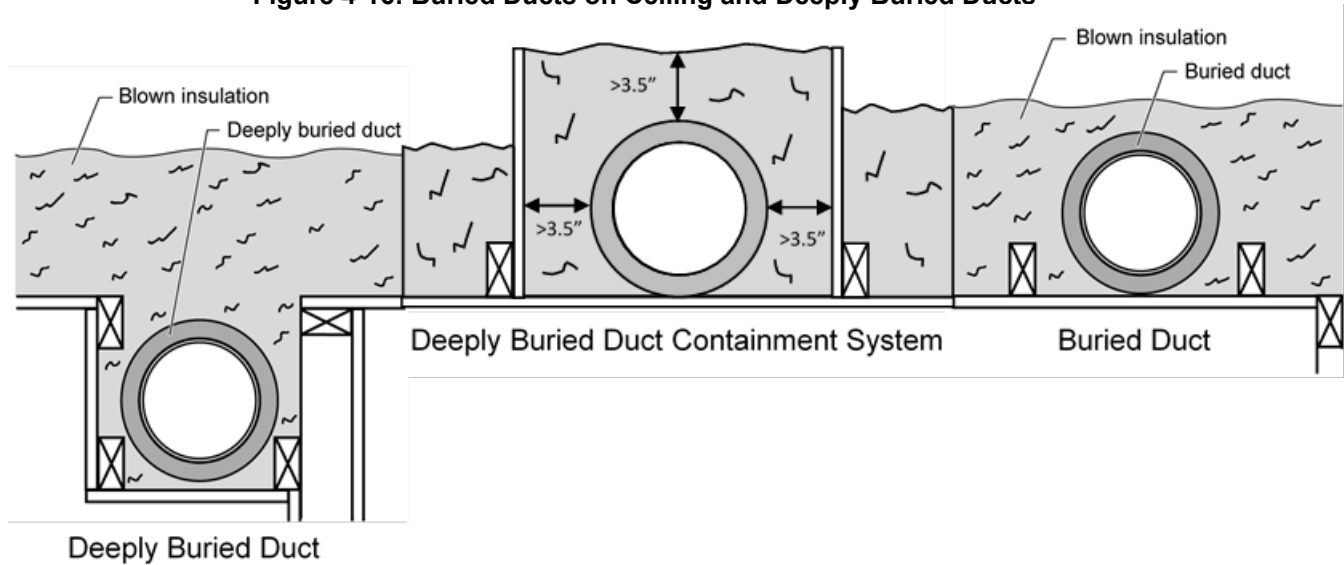

Source: California Energy Commission

Deeply buried containment systems must be installed such that the walls of the system are at least 7 inches wider than the duct diameter (3.5-inch clearance on each side of duct) extend at least 3.5 inches above the duct outer jacket, and the containment area surrounding the duct must be completely filled with blown insulation.

In addition to the above requirements, the attic area containing the buried or deeply buried ducts must have insulation with uniform depth (not mounded over the duct), level ceiling, and at least 6 inches of space between the duct outer jacket and the roof sheathing. Insulation raised by a containment system is an exception to the uniform depth requirement.

To take credit for buried ducts, the system must meet the verified duct system design criteria described above and meet the requirements for Quality Insulation Installation (QII) described in Reference Appendices RA3.5.

4.4.3.6 Ducts in Attics with Radiant Barriers

Installation of a radiant barrier in the attic increases the duct efficiency by lowering attic summer temperatures. Compliance credit for radiant barriers is available in cases where the prescriptive standard does not require radiant barriers and requires listing of the radiant barrier in the special features and modeling assumptions to aid the local enforcement agency's inspections. Compliance credit for a radiant barrier does not require HERS Rater verification.

Radiant barrier must be installed with the appropriate clearance and/or air gap as specified by the manufacturer. Insulation products installed in direct contact with the

radiant barrier may negatively affect the performance of the radiant barrier. When a credit is taken for radiant barrier, an improperly installed radiant barrier assembly will require revision of the CF1R compliance document to remove the energy compliance credit taken.

4.4.4 Duct Installation Standards

The mandatory duct construction measures referenced in Section 4.4.1 above state that duct installations must comply with the California Mechanical Code Sections 601, 602, 603, 604, 605, and the applicable requirements of the Energy Standards. Some highlights of these requirements are listed in this section, along with some guidance for recommended quality construction practice.

4.4.4.1 Tapes and Clamps

All tapes and clamps must meet the requirements of §150.0(m).

Cloth-backed, rubber-adhesive tapes must be used only in combination with mastic and draw bands or have on the backing the phrase "CEC approved," a drawing of a fitting to plenum joint in a red circle with a slash through it (the international symbol of prohibition), and a statement that it cannot be used to seal fittings to plenums and junction box joints.

4.4.4.2 All Joints Must Be Mechanically Fastened

For residential round metal ducts, installers must overlap the joint by at least 1½ inches and use three sheet metal screws equally spaced around the joint. (See Figure 4-17.)

Figure 4-17: Connecting Round Metallic Ducts

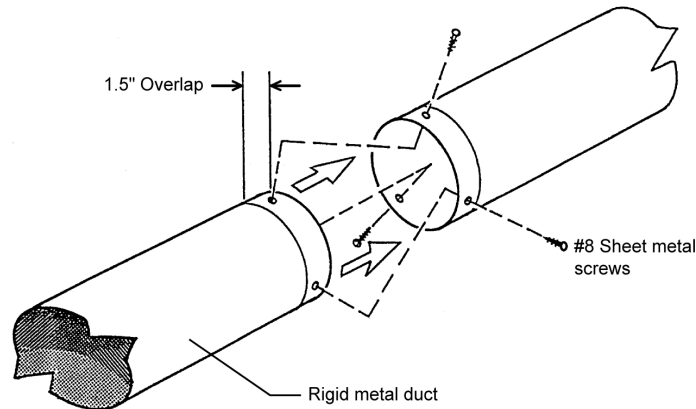

Source: Richard Heath & Associates/Pacific Gas and Electric Company

For round, nonmetallic flex ducts, installers must insert the core over the metal collar or fitting by at least 1 inch. This connection may be completed with either mesh, mastic and a clamp, or two wraps of tape and a clamp.

For a mesh and mastic connection, the installer must first tighten the clamp over the overlapping section of the core, apply a coat of mastic covering both the metal collar and the core by at least 1 inch, and then firmly press the fiber mesh into the mastic and cover with a second coat of mastic over the fiber mesh. (See Figure 4-18.)

Figure 4-18: Connecting Flex Ducts Using Mastic and Mesh

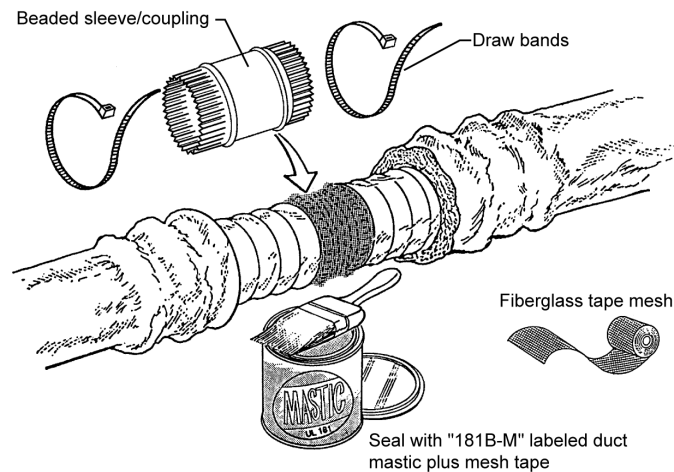

Source: Richard Heath & Associates/Pacific Gas and Electric Company

For the tape connection first apply at least two wraps of approved tape covering both the core and the metal collar by at least 1 inch; then tighten the clamp over the overlapping section of the core. (See Figure 4-19.)

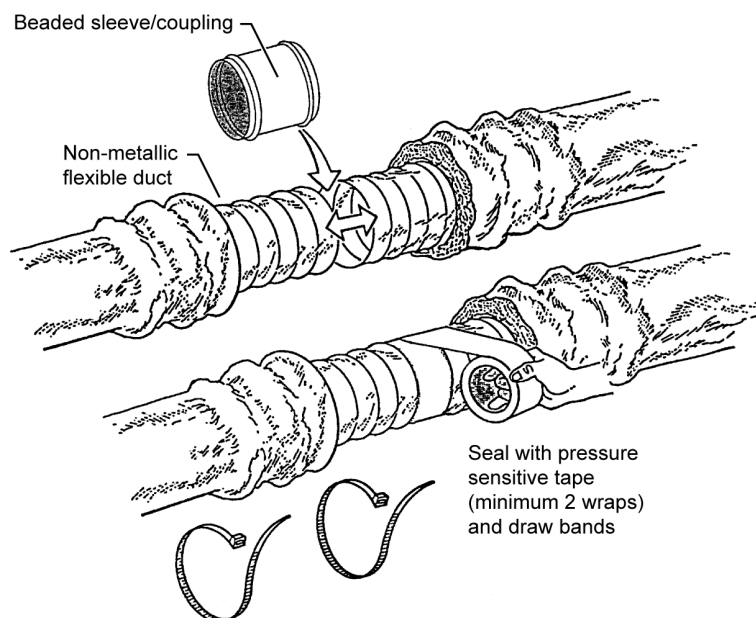
Figure 4-19: Connecting Flex Ducts Using Tape and Clamps

Source: Richard Heath & Associates/Pacific Gas and Electric Company

4.4.4.3 All Joints Must Be Made Airtight

§150(m)

Seal all joints with either mastic, tape, aerosol sealant, or other duct-closure system that meets the applicable requirements of UL 181, UL 181A, UL 181B, or UL 723. Duct systems shall not use cloth-backed, rubber-adhesive duct tape regardless of UL designation, unless it is installed in combination with mastic and clamps. The Energy Commission has approved three cloth-backed duct tapes with special butyl synthetic adhesives rather than rubber adhesive to seal flex duct to fittings. These tapes are:

1. Polyken 558CA, manufactured by Berry Plastics Tapes and Coatings Division.
2. Nashua 558CA, manufactured by Berry Plastics Tapes and Coatings Division.
3. Shurtape PC 858CA, manufactured by Shurtape Technologies, Inc.

These tapes passed Lawrence Berkeley Laboratory tests comparable to those that cloth-backed, rubber-adhesive duct tapes failed. (The LBNL test procedure has been adopted by the American Society of Testing and Materials as ASTM E2342.) These tapes are allowed to be used to seal flex duct to fittings without being in combination with mastic. These tapes cannot be used to seal other duct system joints, such as the attachment of fittings to plenums and junction boxes. These tapes have on the backing a drawing of a fitting to plenum joint in a red circle with a slash through it (the international symbol of prohibition) to illustrate where they are not allowed to be

used, installation instructions in the packing boxes that explain how to install them on duct core to fittings, and a statement that the tapes cannot be used to seal fitting to plenum and junction box joints.

Mastic and mesh should be used where round or oval ducts join flat or round plenums. (See Figure 4-20.)

Figure 4-20: Sealing Metallic Ducts With Mastic and Mesh

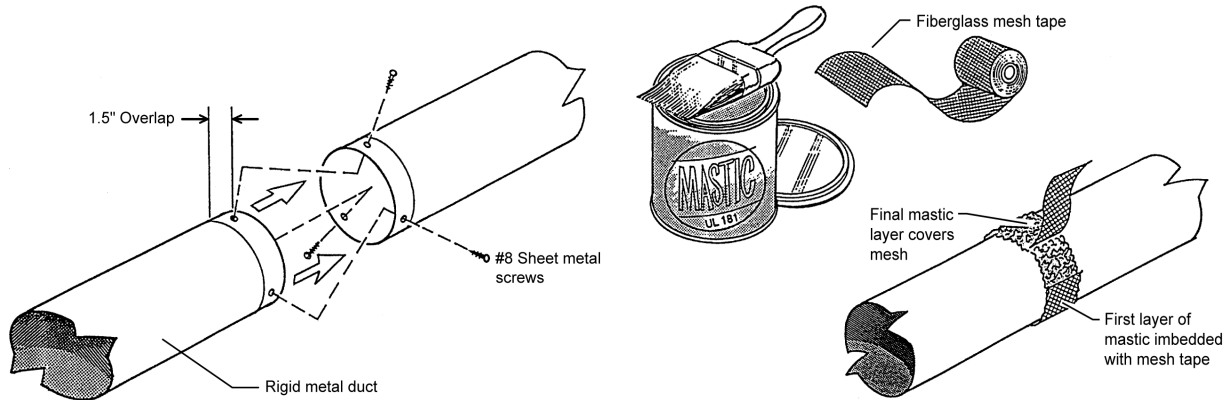

Source: Richard Heath & Associates/Pacific Gas and Electric Company

All ducts must be adequately supported.

Rigid ducts and flex ducts may be supported on rigid building materials between ceiling joists or on ceiling joists.

For rigid round metal ducts that are suspended from above, hangers must occur 12 ft. apart or less. (See Figure 4-21)

Figure 4-21: Options for Suspending Rigid Round Metal Ducts

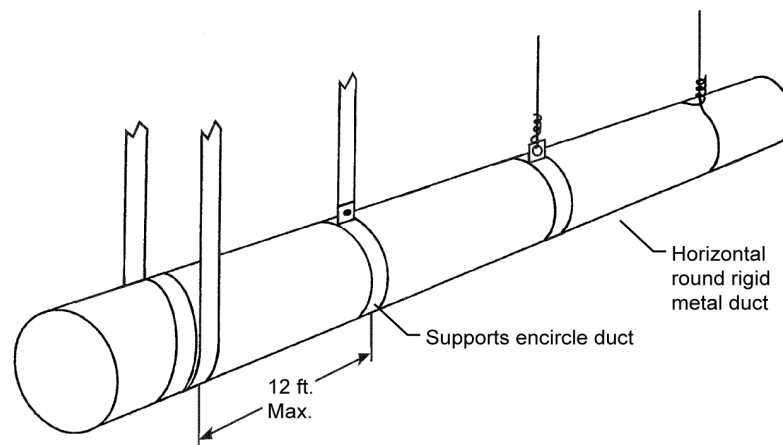

Source: Richard Heath & Associates/Pacific Gas and Electric Company

For rectangular metal ducts that are suspended from above, hangers must occur at a minimum of 4 ft. to 10 ft., depending on the size of the ducts. (See Table 6-2A in Appendix A of the California Mechanical Code and refer to Figure 4-22.)

Figure 4-22: Options for Suspending Rectangular Metal Ducts

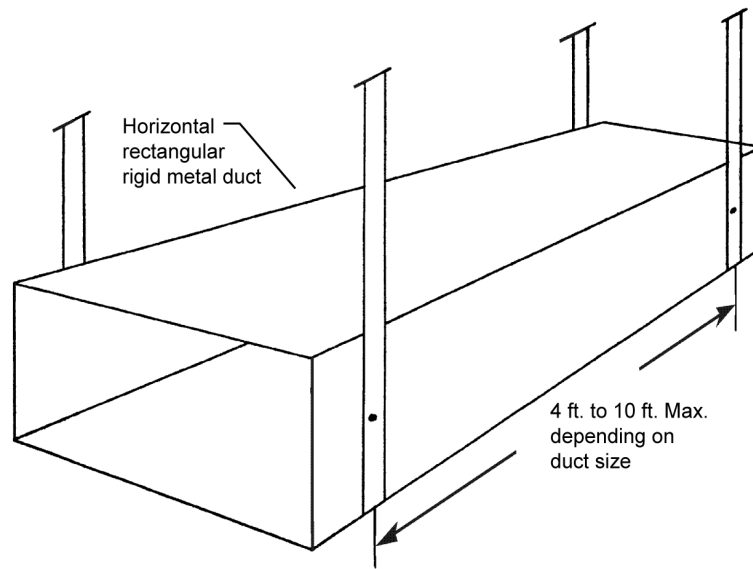

Source: Richard Heath & Associates/Pacific Gas and Electric Company

For flex ducts that are suspended from above, hangers must occur at 4 ft. apart or less, and all fittings and accessories must be supported separately by hangers. (See Figure 4-23.)

Figure 4-23: Minimum Spacing for Suspended Flex Ducts

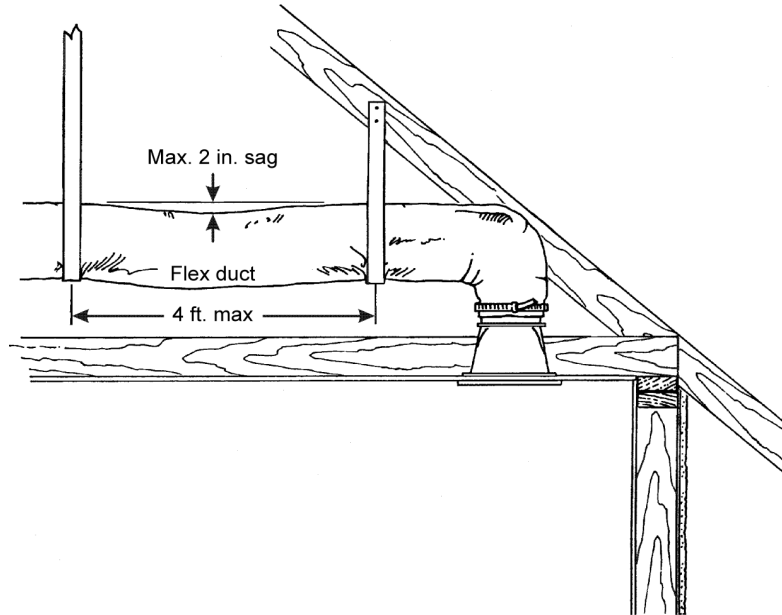

Source: Richard Heath & Associates/Pacific Gas and Electric Company

For vertical runs of flex duct, support must occur at 6 ft. intervals or less. (See Figure 4-24)

Figure 4-24: Minimum Spacing for Supporting Vertical Flex Ducts

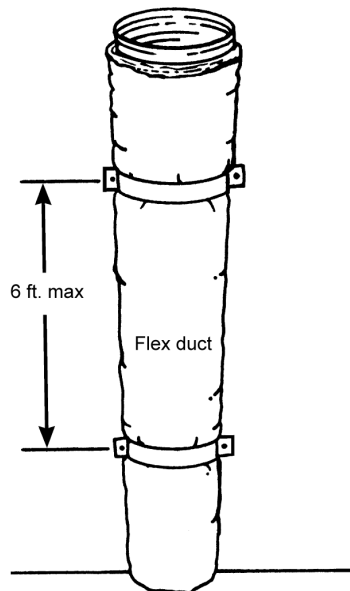

Source: Richard Heath & Associates/Pacific Gas and Electric Company

The routing and length of all duct systems can have significant effects on system performance due to possible increased airflow resistance. The Energy Commission recommends using the minimum length of duct to make connections and the minimum possible number of turns.

For flexible ducts, the Energy Commission recommends fully extending the duct by pulling the duct tightly, cutting off any excess duct, and avoiding bending ducts across sharp corners or compressing them to fit between framing members. (See Figure 4-25) Also avoid incidental contact with metal fixtures, pipes, or conduits or installation of the duct near hot equipment such as furnaces, boilers, or steam pipes that are above the recommended flexible duct use temperature.

Figure 4-25: Minimizing Radius for Flex Duct Bends

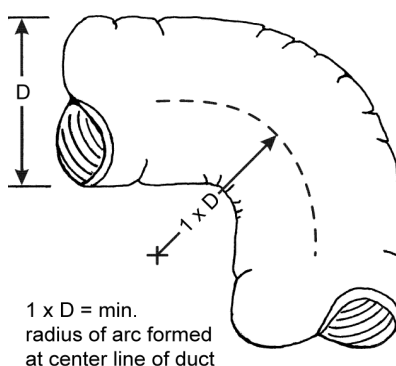

Source: Richard Heath & Associates/Pacific Gas and Electric Company

All joints between two sections of duct must be mechanically fastened and substantially airtight. For a flex duct, this must consist of a metal sleeve no less than 4 inches between the two sections of flex duct.

All joints must be properly insulated. For flex ducts, installers must pull the insulation and jacket back over the joint and use a clamp or two wraps of tape. Aerosol sealant injection systems are an alternative that typically combines duct testing and duct sealing in one process.

Figure 4-26 shows the computer-controlled injection fan temporarily connected to the supply duct. The plenum is blocked off by sheet metal to prevent the sealant from entering the furnace. Supply air registers are also blocked temporarily to keep the sealant out of the house. Ducts must still be mechanically fastened even if an aerosol sealant system is used.

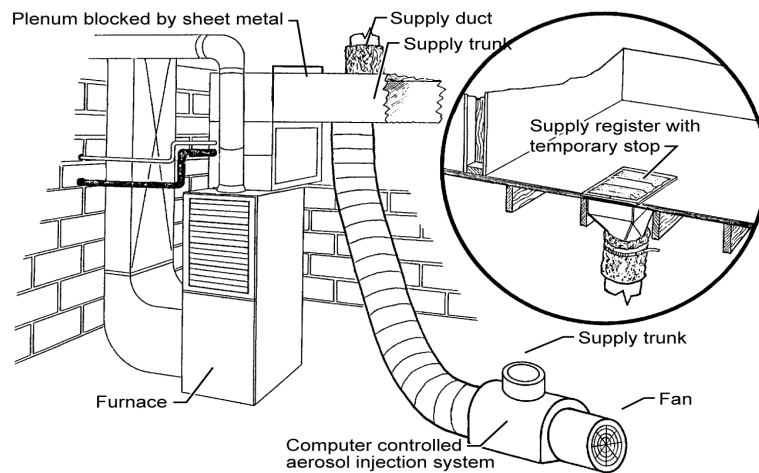
Figure 4-26: Computer-Controlled Aerosol Injection System

Source: Richard Heath & Associates/Pacific Gas and Electric Company

4.5 Controls

4.5.1 Thermostats

Automatic setback thermostats can add comfort and convenience to a home. Occupants can wake up to a warm house in the winter and come home to a cool house in the summer without using unnecessary energy.

§110.2 (b) & (c), §150.0(i)

A thermostat is always required for central systems whether the prescriptive or performance compliance method is used. An exception is allowed only if the system is one of the following non-central types:

1. Non-central electric heaters.
2. Room air conditioners.
3. Room air conditioner heat pumps.
4. Gravity gas wall heaters.
5. Gravity floor heaters.
6. Gravity room heaters.
7. Wood stoves.
8. Fireplace or decorative gas appliances.

When it is required, the setback thermostat must have a clock or other mechanism that allows the building occupant to schedule the heating and/or cooling set points for at least four periods over 24 hours.

If more than one piece of heating equipment is installed in a residence or dwelling unit of a multifamily building, the setback requirement may be met by controlling all heating units by one thermostat or by controlling each unit with a separate thermostat. Separate heating units may be provided with a separate on/off control capable of overriding the thermostat.

Thermostats for heat pumps must be “smart thermostats” that minimize the use of supplementary electric resistance heating during startup and recovery from setback, as discussed earlier in the heating equipment section.

Example 4-6**Question:**

Am I exempt from the requirement for a thermostat if I have a gravity wall heater or any of the equipment types listed in the exception to §110.2(c)?

Answer:

Yes.

4.5.2 Zonal Control for Compliance Credit

An energy compliance credit is provided for zoned heating systems, which save energy by providing selective conditioning for only the occupied areas of a house. A house having at least two zones (living and sleeping) may qualify for this compliance credit. The equipment may consist of one heating system for the living areas and another system for sleeping areas or a single system with zoning capabilities, set to turn off the sleeping areas in the daytime and the living area unit at night. (See Figure 4-27)

Figure 4-27: Zonal Control Example

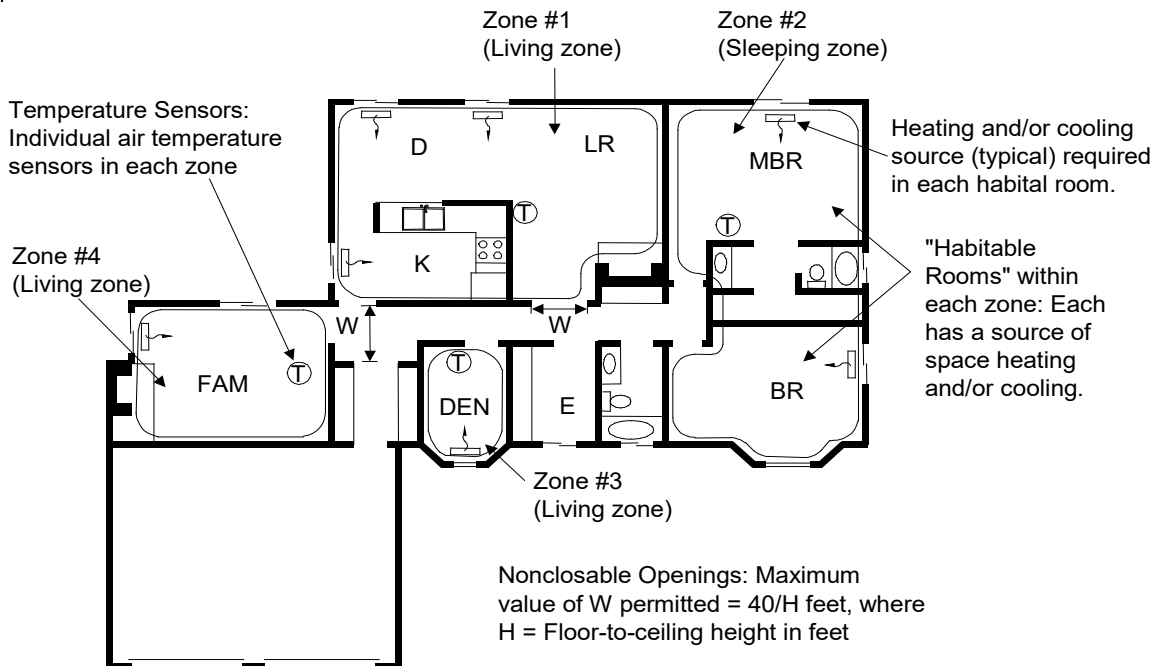

Source: Richard Heath & Associates/Pacific Gas and Electric Company

There are unique eligibility and installation requirements for zonal control to qualify under the Energy Standards. The following steps must be taken for the building to show compliance with the standards under this exceptional method:

1. **Temperature Sensors.** Each thermal zone, including a living zone and a sleeping zone, must have air temperature sensors that provide accurate temperature readings of the typical condition in that zone.
2. **Habitable Rooms.** For systems using central forced-air or hydronic heating, each habitable room in each zone must have a source of space heating, such as forced-air supply registers, radiant tubing, or a radiator. For systems using a combination of a central system and a gas-vented fireplace or other conditioning units, the zone served by the individual conditioning unit can be limited to a single room. Bathrooms, laundry, halls and/or dressing rooms are not habitable rooms.
3. **Noncloseable Openings.** The total noncloseable opening area (W) between adjacent living and sleeping thermal zones (such as halls, stairwells, and other openings) must be less than or equal to 40 ft². All remaining zonal boundary areas must be separated by permanent floor-to-ceiling walls and/or fully solid, operable doors capable of restricting free air movement when closed.
4. **Thermostats.** Each zone must be controlled by a central automatic dual-setback thermostat that can control the conditioning equipment and maintain preset temperatures for varying periods in each zone independent of the other.

Thermostats controlling vented gas fireplace heaters that are not permanently mounted to a wall are acceptable as long as they have the dual-setback capabilities.

Other requirements specific to forced-air-ducted systems include the following:

1. Each zone must be served by a return air register located entirely within the zone. Return air dampers are not required.
2. Supply air dampers must be manufactured and installed so that when they are closed, there is no measurable airflow at the registers.
3. The system must be designed to operate within the equipment manufacturer's specifications.
4. Air is to positively flow into, though, and out of a zone only when the zone is being conditioned. No measurable amount of supply air is to be discharged into unconditioned or unoccupied space to maintain proper airflow in the system.

Although multiple thermally distinct living and/or sleeping zones may exist in a residence, the correct way to model zonal control for credit requires only two zones: a living zone and a sleeping zone. All separate living zone components must be modeled as one living zone; the same must be done for sleeping zones.

Example 4-7

Question:

In defining the living and sleeping zones for a home with a zonally controlled HVAC system, can laundry rooms and bathrooms (which are not habitable spaces) be included on whichever zone they are most suited to geographically (for example, a bathroom located near bedrooms)?

Answer:

Yes. For computer modeling, include the square footage of any nonhabitable or indirectly conditioned spaces with the closest zone.

Example 4-8

Question:

I have two HVAC systems and want to take zonal control credit. Can the return air grilles for both zones be located next to each other in the 5 ft. wide by 9 ft. high hallway (in the same zone)?

Answer:

No. Because of the need to prevent mixing of air between the conditioned zone and the unconditioned zone, it is necessary to (1) have the return air for each zone within that zone, and (2) limit any noncloseable openings between the two zones to 40 ft² or less. Unless these criteria and the other criteria listed in this chapter can be met, credit for a zonally controlled system cannot be taken.

Example 4-9

Question:

Can a gas-vented fireplace be used for zonal control heating, and qualify for the zonal control credit?

Answer:

Gas-vented fireplaces that meet zonal control requirements may qualify for the zonal control credit.

Example 4-10

Question:

Does a gas-vented fireplace with a handheld remote thermostat meet the thermostat requirement for the two-zone modeling credit?

Answer:

Yes, as long as the thermostat has manual “on” to start, automatic setback capability, and temperature preset capability, it does not have to be permanently wall-mounted.

4.6 Indoor Air Quality and Mechanical Ventilation

§150.0(o), §150.2(a)1C, and §150.2(a)2C

As residential buildings have been tightened over the last several code cycles to improve energy performance, the dilution of indoor air through natural ventilation has been significantly reduced. As a result, the importance of controlling indoor pollutants generated by kitchen ranges during food preparation and from common building materials, cleaners, finishes, packaging, furniture, carpets, clothing, and other products has increased. Energy Commission-sponsored research has revealed that concentration of pollutants such as formaldehyde are higher than expected, and that many occupants do not open windows regularly for ventilation. The 2019 Energy Standards include requirements for mandatory mechanical ventilation intended to improve indoor air quality (IAQ) in homes, and requirements for MERV 13 air filtration on space conditioning systems, and ventilation systems that provide outside air to the occupiable space of a dwelling.

As specified by §150.0(o), single-family detached dwelling units, and multifamily attached dwelling units must meet the requirements of ASHRAE Standard 62.2-2016 including Addenda b, d, l, q, and s (ASHRAE 62.2), subject to the amendments specified in Section 150.0(o)1. A copy of this version of ASHRAE 62.2 may be obtained at the following URL:

[insert link to ASHRAE bookstore for this version of ASHRAE 62.2 when it becomes available]

Opening and closing windows and continuous operation of central fan-integrated ventilation systems are not allowable options for meeting dwelling unit ventilation requirements. The requirements of ASHRAE Standard 62.2 focus on providing continuous dwelling unit mechanical ventilation, as well as local exhaust ventilation at known sources of pollutants or moisture, such as kitchens, bathrooms, and laundries.

Limiting the sources of indoor pollutants is one important method for protecting indoor air quality. Kitchen ranges used for preparation of food have been identified as a source of indoor air pollution that must be addressed, and builders should adhere to the requirements of Section 4.504 of the California Green Building Standards Code for the selection of materials and finishes that have no or low emissions of air pollutants such as formaldehyde and volatile organic compounds (VOCs). The California Air Resources Board (CARB) also provides guidance for reducing indoor air pollution in homes. For more information, see the CARB Indoor Air Quality Guidelines:

<http://www.arb.ca.gov/research/indoor/guidelines.htm>

This section will cover compliance and enforcement, typical design solutions, energy consumption issues, and other requirements specified by ASHRAE 62.2 as amended in the 2019 Title 24 standards. The key changes in the adopted 2016 version of ASHRAE 62.2 and Title 24 Part 6 amendments to 62.2 include the following:

1. ASHRAE 62.2 now covers mid-rise and high-rise residential occupancies, as well as single-family detached and low-rise attached multifamily dwellings.
2. For single-family homes, the standard requires higher rates of dwelling unit mechanical ventilation than previously. An adjustment to the ventilation rate is provided to account for the effects of the envelope infiltration, which varies by climate zone (Table 4-14). Homes sealed to a leakage rate of less than 2 ACH50 will require larger fans to compensate for the decrease in effective ventilation due to infiltration.
3. Single-family detached dwellings and townhomes using balanced ventilation systems will require lower ventilation rates as compared to the rates required when exhaust or supply-only ventilation is used.
4. Compliance with required dwelling unit ventilation using *variable* mechanical ventilation systems (intermittent or variable operation) requires the average mechanical ventilation rate (in CFM) over a three-hour period to be greater than or equal to the ventilation rate used for continuous ventilation. Otherwise, more complicated control strategies may be used if the system operation complies with the “relative exposure” calculations in normative Appendix C of ASHRAE 62.2.
5. Two options for compliance with dwelling unit ventilation are allowed for multifamily attached dwelling units: (1) installation of a balanced ventilation

system or (2) installation of an exhaust or supply-only system accompanied by sealing to a leakage rate of not more than 0.3 CFM50 per ft² of dwelling unit enclosure surface area.

6. Kitchen range hood fans are now required to be verified by a HERS Rater. The new verification protocol requires comparing the installed model to ratings in the Home Ventilating Institute (HVI) directory of certified ventilation products to confirm the installed range hood is rated to meet the required airflow and sound requirements specified in ASHRAE 62.2. See section 4.6.7 below for more detail. Kitchen range hood fans that exhaust more than 400 CFM at minimum speed are exempt from this requirement.

Compliance with the dwelling unit ventilation airflow specified in ASHRAE 62.2 is required in new dwelling units, in new dwelling units that are additions to an existing building, and in additions to existing dwelling units that increase the conditioned floor area of the existing dwelling unit by more than 1,000 square feet. Alterations to components of existing buildings that previously met any requirements of ASHRAE 62.2 must continue to meet requirements upon completion of the alteration(s).

The following summarizes the key requirements for most newly constructed buildings:

1. A dwelling unit mechanical ventilation system shall be provided. Typical solutions are described in Section 4.6.2 below. The airflow rate provided by the system shall be confirmed through field verification and diagnostic testing in accordance with the applicable procedures specified in Reference Residential Appendix RA3.7.
2. Kitchens and bathrooms shall have local exhaust fans vented to outdoors.
3. Clothes dryers shall be vented to outdoors.

Miscellaneous indoor air quality design requirements also apply, including the following:

1. Ventilation air shall come from outdoors and shall not be transferred from adjacent dwelling units, garages, unconditioned attics or crawl spaces.
2. Ventilation system controls shall be labeled, and the homeowner shall be provided with instructions on how to operate the system.
3. Combustion appliances shall be properly vented, and exhaust systems shall be designed to prevent back drafting.
4. Walls and openings between the house and the garage shall be sealed or gasketed.
5. Habitable rooms shall have windows with an opening ventilation area of at least 4 percent of the floor area.
6. Mechanical systems including heating and air-conditioning systems that supply air to habitable spaces shall have MERV 13 filters or better and be designed to

accommodate the rated pressure drop of the system air filter at the designed airflow rate.

7. Dedicated air inlets (not exhaust) that are part of the ventilation system design shall be located away from known sources of outdoor contaminants.
8. A carbon monoxide alarm shall be installed in each dwelling unit in accordance with NFPA Standard 720.
9. Air-moving equipment used to meet the dwelling unit ventilation requirement and the local ventilation exhaust requirement shall be rated in terms of airflow and sound:
 - a. Dwelling unit ventilation and continuously operating local exhaust fans must be rated at a maximum of 1.0 sone (measurement of sound).
 - b. Demand-controlled local exhaust fans must be rated at a maximum of 3.0 sone.
 - c. Kitchen exhaust fans must be rated at a maximum of 3.0 sone at one or more airflow settings greater than or equal to 100 CFM.
 - d. Remotely located air-moving equipment (mounted outside habitable spaces) are exempt from the sound requirements provided there is at least 4 feet of ductwork between the fan and the interior grille.

4.6.1 Compliance and Enforcement

Compliance with ASHRAE 62.2 requirements must be verified by the enforcement agency, except for the following requirements that must be HERS verified in accordance with the procedures in Residential Appendix RA3.7:

- Dwelling unit ventilation airflow rate
- HVI ratings for kitchen range hood fans

All applicable certificates of compliance, installation, and verification must be registered with an approved HERS Provider.

Title 24 Part 6 amendments to ASHRAE 62.2 eliminated the requirement to use the result of a blower door measurement when calculating the required dwelling unit mechanical ventilation rate (Q_{fan}). Instead, the Q_{fan} calculation applies a default infiltration leakage rate equivalent to 2 ACH₅₀. Blower door testing to measure actual dwelling unit enclosure leakage is required only when performance compliance modeling uses an infiltration leakage rate less than 2 ACH₅₀ - which requires HERS verification of dwelling unit enclosure leakage for energy compliance as well as for determining Q_{fan} .

If a central heating/cooling system air-handler fan is used to ventilate the dwelling (central fan-integrated ventilation, also known as CFI ventilation), the air-handler must meet or exceed the mandatory fan efficacy criteria. This requires the installer to perform the test given in Reference Appendix RA3.3 and a HERS Rater to verify the efficacy (W/CFM) of the air-handling unit fan.

4.6.1.1 Certificate of Compliance Reporting Requirements

When using the prescriptive compliance approach, the mechanical ventilation rate (Q_{fan}) must be manually calculated using the applicable equations in Standards Section 150.0(o)1, also shown in Section 4.6.4 below. The value for Q_{fan} is required to be reported on the CF1R. When using the performance method, the compliance model automatically calculates Q_{fan} based on the inputs for conditioned floor area, number of bedrooms, and climate zone (Table 4-14), and uses the Q_{fan} ventilation airflow value when calculating the building energy use. The performance certificate of compliance (CF1R) will report the:

1. Minimum mechanical ventilation airflow rate (calculated value) that must be delivered by the system.
2. Type of ventilation system (exhaust, supply, balanced, CFI).
3. Fan efficacy (W/CFM) for the selected system.
4. Recovery efficiency (%) (applicable to HRV/ERV system types only)
5. For CFI systems--HERS verification of air handler fan efficacy is required.

The installed dwelling unit ventilation system must conform to the performance requirements on the CF1R.

The enforcement agency may require additional information/documentation describing the ventilation systems be submitted along with the CF1R at plan check.

4.6.1.2 Certificate of Installation and Certificate of Verification Reporting Requirements

The builder/installer must complete certificates of installation (CF2R-MCH-01 and CF2R-MCH-27) for the dwelling. The HERS Rater must complete a certificate of verification (CF3R-MCH-27) for the dwelling.

4.6.1.2.1 CF2R-MCH-01

The following information must be provided on the CF2R-MCH-01 to identify each ventilation system/fan in the dwelling that will require HERS verification.

For dwelling unit ventilation systems:

1. Ventilation system name or identification
2. Ventilation system location
3. Ventilation system control type (i.e. continuous, variable)
4. Ventilation system type (i.e. exhaust, supply, balanced, CFI).
5. Ventilation system target airflow rate (may be less than Q_{fan} if using multiple systems/fans to comply)
6. Ventilation system manufacturer name
7. Ventilation system model number

8. Control system manufacturer (if applicable)
9. Control system model number (if applicable)
10. Energy Commission certification number for variable system/control (if applicable)

For kitchen exhaust ventilation systems:

1. Kitchen exhaust control type (i.e. demand-controlled, continuous)
2. Kitchen exhaust system type (i.e. range hood, over the range (OTR) microwave, downdraft, local exhaust, other).
3. Kitchen exhaust system required airflow rate
4. Kitchen exhaust system manufacturer name
5. Kitchen exhaust system model number
6. Kitchen exhaust system HVI certification number

4.6.1.2.2 CF2R-MCH-27

The following additional information must be provided on the CF2R-MCH-27 to document compliance with §150.0(o). Refer also to the procedures in RA 3.7.4.

For dwelling unit ventilation systems:

- Measured airflow rate of the installed dwelling unit ventilation system. For balanced systems, exhaust and supply airflows must be measured and recorded.

For kitchen exhaust ventilation systems:

- Confirmation the installed system is rated by HVI to meet the required airflow and sound requirements.

For all ventilation systems:

- Confirmation that the other applicable requirements given in Sections 6 and 7 of ASHRAE 62.2 as amended in 150.0(o)1 have been met (see Sections 4.6.7 and 4.6.8 below).

4.6.1.2.3 CF3R-MCH-27

The following additional information must be provided on the CF3R-MCH-27 to document compliance with §150.0(o):

For dwelling unit ventilation systems:

- Measured airflow rate of the installed dwelling unit ventilation system. For balanced systems, both exhaust and supply airflows must be measured and recorded.

For kitchen exhaust ventilation systems:

- Confirmation the installed system is rated by HVI to meet the required airflow and sound requirements.

4.6.2 Typical Solutions for Single-Family Dwelling Unit Ventilation

From ASHRAE 62.2, Section 4.2, System Type.

The dwelling-unit mechanical ventilation system shall consist of one or more supply or exhaust fans and associated ducts and controls. Local exhaust fans shall be permitted to be part of a mechanical exhaust system. Where local exhaust fans are used to provide dwelling-unit ventilation, the local exhaust airflow may be credited toward the dwelling-unit ventilation airflow requirement. Outdoor air ducts connected to the return side of an air handler shall be permitted as supply ventilation if manufacturers' requirements for return air temperature are met.

There are four typical solutions for meeting the dwelling unit outside air ventilation requirement:

1. Exhaust ventilation - air is exhausted from the dwelling unit and replaced by infiltration.
2. Supply ventilation - outdoor air is supplied directly to the dwelling unit after being filtered.
3. Central fan-integrated ventilation - outdoor air is ducted to the return plenum of the central space conditioner air handler. Both return air and outdoor air must be filtered.
4. Balanced ventilation – may be a single packaged unit containing supply and exhaust fans that move approximately the same airflow through a heat or energy recovery core, or may use separate fans without heat exchange. In both cases, air supplied from outdoors must be filtered. (See Section 4.4.1.14 for filter requirements.)

4.6.2.1 Exhaust Ventilation

Exhaust ventilation is typically provided using a quiet, continuously operating ceiling-mounted fan or attic-mounted inline fan. Air is drawn from the house or unit and exhausted to the outdoors. Outdoor air enters the house or unit through infiltration. Many high-quality, quiet fans are available for this purpose. For larger homes, more than one fan may be used. The same fan can be used to meet dwelling unit and local (bathroom or laundry) exhaust ventilation requirements. Inline fans can be used to exhaust air from one or more bathrooms. Remotely located fans (fans mounted outside habitable spaces) are exempt from the sound requirements if there is at least 4 feet of ductwork between the fan and the interior grille.

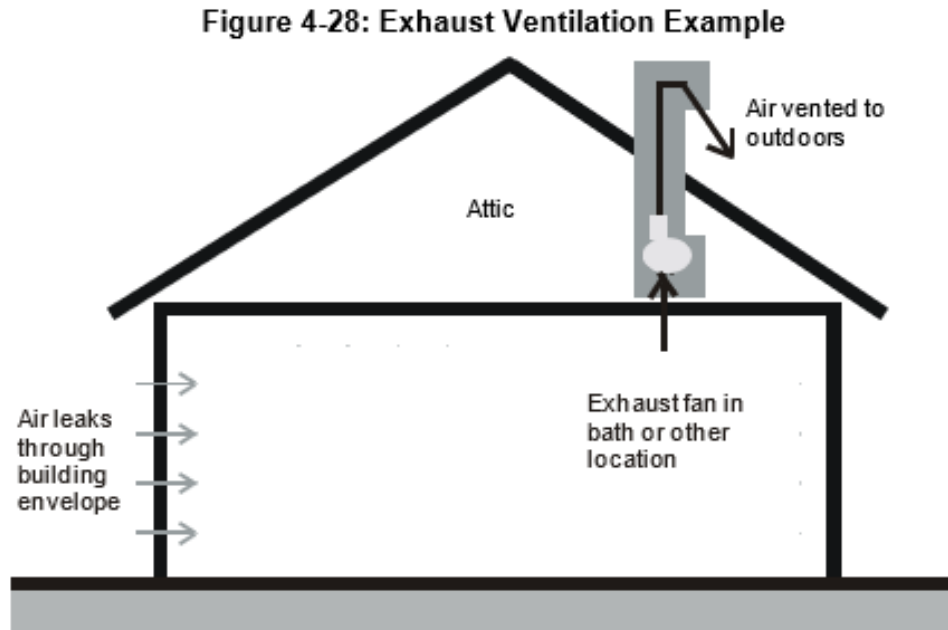

Source: California Energy Commission

4.6.2.2 Supply Ventilation

Supply ventilation systems draw outdoor air into the house using a dedicated supply fan and most likely distribute ventilation air through supply ductwork, although that is not a requirement. Indoor air escapes through leaks in the building envelope (exfiltration), as shown in Figure 4-29. For larger homes, more than one fan may be used. Remotely located fans (fans mounted outside habitable spaces) are exempt from the sound requirements if there is at least 4 feet of ductwork between the fan and the interior grille. Thus, if less than 4 feet of ductwork are used, the supply fan must meet the maximum 1.0 sone rating requirement for dwelling unit ventilation fans.

Figure 4-29: Supply Ventilation Example

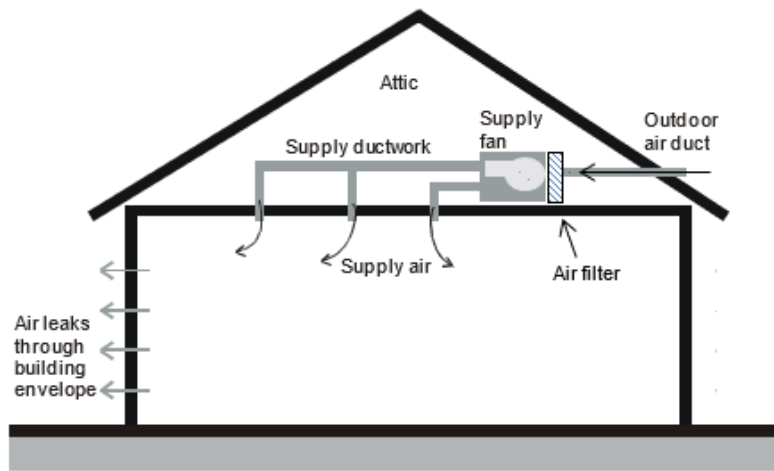

Source: California Energy Commission

Section 150.0(m)12 requires that outside air be filtered using MERV 13 (or greater) particle removal efficiency rated air filters. The filters must be accessible to facilitate replacement. Supply systems may locate the MERV 13 air filter either upstream or downstream of the fan as long as the incoming outdoor air is filtered prior to delivery to the dwelling unit habitable space. Fans may be located in attics, dropped ceiling spaces, or other spaces dedicated for installation of mechanical equipment.

The outdoor air inlet should be located to avoid areas with contaminants such as smoke produced in barbeque areas and products of combustion emitted from gas appliance vents. Air may not be drawn from attics or crawlspaces. To minimize drafts and optimize distribution, supply air can be ducted directly to bedrooms and living areas using an appropriately sized and sealed ventilation-only duct system or by connecting to the HVAC supply plenum.

4.6.2.3 Central Fan-Integrated (CFI) Ventilation

The central forced-air system air handler can be configured to function as a ventilation supply system by installing an outdoor air duct that connects the return plenum of the air-handler to outdoors. This strategy, called CFI ventilation, uses negative pressure in the return plenum to draw in outdoor air, which is mixed and distributed with a larger volume of return air from the house. A motorized damper and special CFI controls must be installed to ensure the air handler delivers the required ventilation airflow regardless of whether the heating/cooling system operates to provide space conditioning. Thus, when the heating/cooling operating time is reduced during times when space conditioning is not needed, the CFI controls will operate only the system fan and outdoor air damper to provide ventilation air even if space conditioning is not needed. Because of the relatively high energy use of the central system fan, CFI systems consume greater amounts of energy compared to exhaust or supply or balanced ventilation systems. Continuous

operation of the CFI air handler fan to provide the required dwelling unit ventilation is prohibited.

Figure 4 30: Central Fan-Integrated (CFI) Ventilation Example

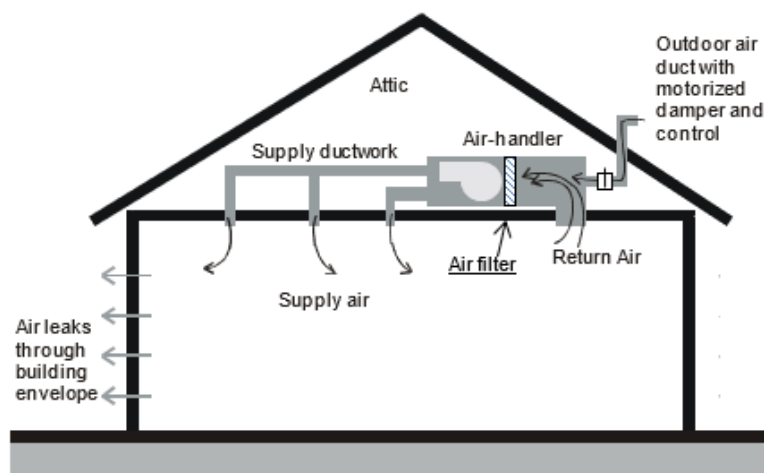

Source: California Energy Commission

Section 150.0(m)12 requires that outside air be filtered using MERV 13 (or greater) particle removal efficiency rated air filters. Filters must be accessible to simplify replacement. For CFI systems, the filters must be installed upstream of the cooling or heating coil; thus, the filter rack provided at the inlet to the air handler may be used. Otherwise, filters must be provided at the return grill(s) for the central fan, and another filter must be provided in the outside air ductwork before the point the outside air enters the return plenum of the central fan.

When considering system design and HERS verification compliance for CFI ventilation systems, it is important to distinguish between the central forced-air system fan total airflow and the much smaller outdoor ventilation airflow rate (the airflow that is induced to flow into the return plenum from outdoors). Both of these airflows must be verified by a HERS Rater. Refer to Figure 4-30 and note that the total airflow through the air handler is the sum of the return airflow and the ventilation airflow.

CFI ventilation systems, devices, and controls may be approved for use for compliance with the HERS field verification requirements for dwelling unit mechanical ventilation airflow. CFI ventilation systems must be automatically controlled by a timer or other device that assures they will operate the minimum amount of time needed to meet the ventilation requirement. The scheduling of the automatic controls must be such that the fan operates at least once every three hours and the average dwelling unit ventilation rate over any 3-hour period must be greater than or equal to the required ventilation rate Q_{fan} calculated using the applicable equations in Standards Section 150.0(o)1 (also shown in Section 4.6.4 below).

Section 150.0(o)1B specifically prohibits continuous operation of the central forced-air system of a CFI ventilation system, so CFI ventilation systems must operate

intermittently and be certified to the Energy Commission as an intermittent or variable system that will meet the minimum ventilation airflow required by Section 150.0(o).

A listing of certified CFI ventilation systems is posted at the following URL:

http://www.energy.ca.gov/title24/equipment_cert/imv/

The outside air ducts for CFI ventilation systems are not allowed to be sealed/taped off during duct leakage testing. However, CFI outdoor air ductwork that uses controlled motorized dampers that open only when outdoor air ventilation is required and close when outdoor air ventilation is not required may be closed during duct leakage testing.

Because CFI ventilation systems can use a large amount of electricity annually compared to other ventilation system types, the air handlers used in CFI ventilation systems are required to meet the fan watt draw requirements given in Section 150.0(m)13B in all climate zones.

4.6.2.4 **Balanced Ventilation**

Balanced systems use an exhaust fan and a supply fan to move approximately the same volume of air into and out of the dwelling. To be considered a balanced ventilation system, the total supply airflow and the total exhaust airflow must be within 20 percent of each other. For determining compliance, the average of the supply and exhaust airflows is equal to the balanced system airflow rate. (Refer to RA3.7.4.1.2.)

Some balanced systems are small packaged systems that include heat exchangers that temper incoming air with outgoing air, which reduces the thermal effect of ventilation on heating and cooling loads, but the dual fans also increase electrical energy use. They are most practical for use in tightly sealed houses and in multifamily units where exhaust type systems have difficulty drawing adequate outside air due to limited exterior wall area.

Like supply ventilation systems, balanced systems are required to be equipped with MERV 13 or better filters to remove particles from outside airflow. An example of a heat recovery ventilator is shown in Figure 4-31.

The outdoor air inlet should be located to avoid areas with contaminants such as smoke produced in barbeque areas and products of combustion emitted from gas appliance vents. Air may not be drawn from attics or crawlspaces.

Figure 4-31: Balanced Ventilation Example 1 – HRV or ERV

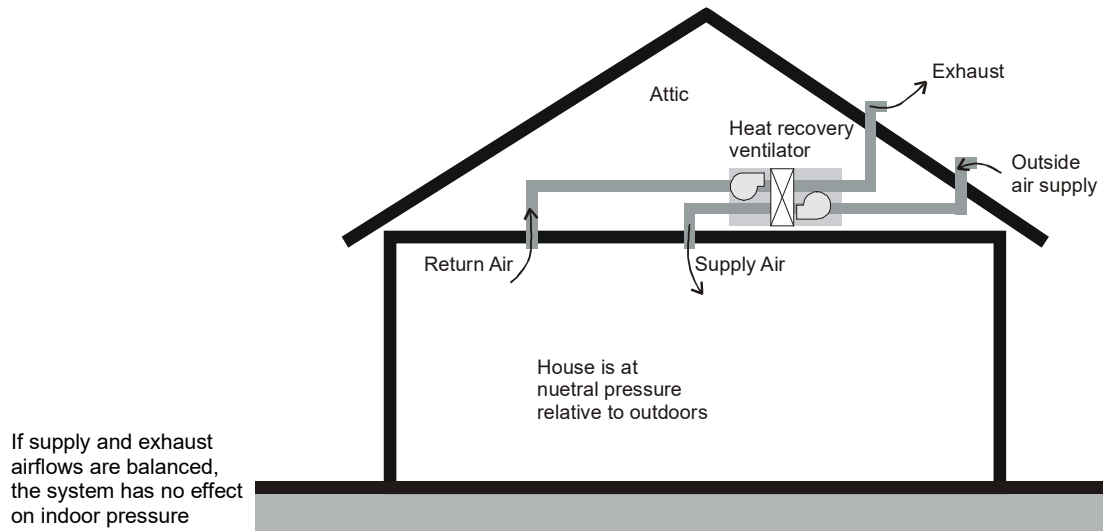

Source: California Energy Commission

Another balanced system configuration uses a stand-alone supply fan coupled with a stand-alone exhaust fan, both wired to a common switch or control to ensure they operate simultaneously. The controls must make it possible to adjust the speed of the fans for balancing the airflows. An example is shown in Figure 4-32.

Figure 4-32: Balanced Ventilation Example 2 – Separate Supply and Exhaust Fan

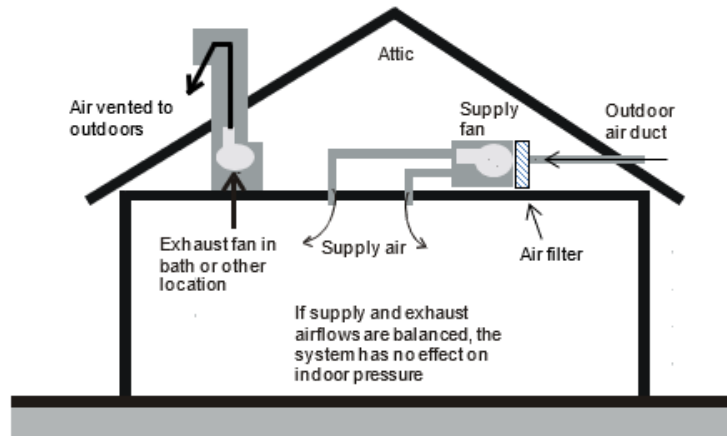

Source: California Energy Commission

4.6.3 Typical Solutions for Multifamily Dwelling Unit Ventilation

4.6.3.1 System Types

There are generally three system types available for meeting the dwelling unit ventilation requirement (refer to Section 4.6.2 for descriptions of the system types described below):

1. Exhaust ventilation – air is exhausted from the dwelling unit and replaced by infiltration.
2. Supply ventilation – outdoor air is supplied directly to the dwelling unit after being filtered.
3. Balanced ventilation – may be a single packaged unit containing supply and exhaust fans that moves approximately the same airflow through a heat or energy recovery core or may use separate fans without heat exchange. In both cases, air supplied from outdoors must be filtered. (See Section 4.4.1.14 for air filter requirements.)

Exhaust and balanced systems are most frequently used in multifamily buildings, but supply ventilation may also be used. Exhaust (or supply) systems in low-rise buildings typically use fans located in the dwelling units that exhaust directly to the outdoors.

4.6.3.2 Multifamily Building Central Shaft Ventilation Systems

Use of central ventilation fans/shafts that are shared with multiple dwelling units in the building are more common in mid-rise and high-rise buildings. When a supply or exhaust system provides dwelling unit ventilation to more than one dwelling unit, the airflows in each dwelling unit must be equal to or greater than the required (minimum) ventilation rate, and the airflows for each dwelling unit must also be balanced to be no more than 20 percent greater than the specified rate (See Standards Section 150.0(o)1F). The specified rate for the systems that share a common fan/shaft may be the minimum rate required for compliance, in which case each of the dwellings receiving airflow from a common fan/shaft must have ventilation airflow no more than 20 percent greater than the minimum dwelling unit ventilation airflow required by Equation 150.0-B. If the lowest airflow provided to any of the dwellings served by the common fan/shaft is a specific percent value greater than the minimum required for compliance, then each of the dwellings receiving airflow from that common fan/shaft must have ventilation airflow no more than 20 percent greater than that lowest dwelling unit ventilation airflow. For example, if the lowest ventilation airflow among all dwellings served by the common fan/shaft is 2 percent greater than the minimum required for compliance, then all dwellings served by the common fan/shaft must be balanced to have ventilation airflow that is no more than 22 percent greater than the minimum ventilation airflow required for compliance.

These systems must use balancing devices to ensure the dwelling-unit airflows can be adjusted to meet this balancing requirement. These system balancing devices

may include, but are not limited to, constant air-regulation devices, orifice plates, and variable-speed central fans.

Since supply and exhaust ventilation system types are required to operate continuously in multifamily dwellings (see Section 150.0(o)1Eii), and since CFI systems are prohibited from operating continuously to provide the required dwelling unit ventilation (see Section 150.0(o)1B), the CFI ventilation system type is not allowed to be used in multifamily dwellings.

4.6.3.3 Multifamily Dwelling Unit Compartmentalization – Reducing Dwelling Unit Enclosure Leakage

Transfer air is the airflow between adjacent dwelling units in a multifamily building that can be a major contributor to poor indoor air quality in the dwelling units. Transfer airflow is caused by differences in pressure between adjacent dwelling units that force air to flow through leaks in the dwelling unit enclosure. The pressure differences may be due to stack effects and wind effects, but unbalanced mechanical ventilation is also a major contributor to this problem. It is desirable to minimize or eliminate leaks in all the dwelling enclosures in the building – to compartmentalize the dwellings - to prevent pollutants such as tobacco smoke, pollution generated from food preparation in the kitchen, odors, and other pollutants from being transferred to adjacent dwellings in the building.

Title 24 provides two compliance paths for mechanical ventilation which improve compartmentalization in multifamily buildings (choose one):

1. Install a balanced ventilation system. This may consist of either a single ventilation unit (such as an ERV or HRV) or may consist of separate supply and exhaust fans that operate simultaneously and are controlled to balance the supply and exhaust airflows. The outdoor ventilation supply air must be filtered (MERV 13 or better).
2. Verify that the dwelling unit leakage is not greater than 0.3 CFM per ft² of dwelling unit enclosure area using the procedures in RA3.8 (blower door test). If the dwelling unit enclosure passes this blower door test, use of continuously operating supply ventilation systems, or continuously operating exhaust ventilation systems in that dwelling is allowed.

4.6.4 Dwelling Unit Ventilation Airflow Measurement

Residential Appendix RA3.7.4 provides direction for measurement of supply, exhaust, and balanced system types. These measurement procedures are applicable when there is a fixed airflow rate required for compliance, such as for systems that operate continuously at a specific airflow rate or systems that operate intermittently at a fixed speed (averaged over any three-hour period), according to a fixed timer pattern for which the programmed pattern is verifiable by a HERS Rater on site. (Refer to ASHRAE 62.2 Section 4.5.1 Short Term Average Ventilation.)

Variable or intermittent operation that complies with ASHRAE 62.2 Sections 4.5.2 and 4.5.3 complies with the dwelling unit mechanical ventilation requirements by use of varying ventilation airflow rates based on complicated calculations for relative exposure as specified in ASHRAE 62.2 Normative Appendix C. These calculation procedures provide the basis for "smart" ventilation controls implemented by use of digital controls that rely on the manufacturer's product-specific algorithms or software. Any ventilation system models that use these complex ventilation system controls in a ventilation product designed to be used to comply with Standards Section 150.0(o) must submit an application to the Energy Commission to have the ventilation technology approved. These manufacturers are expected to provide with their applications evidence that the system will perform to provide the required dwelling unit mechanical ventilation. The manufacturers are also expected to provide a method that could be used by a HERS Rater to verify that an installed system is operating as designed.

Listings of systems approved by the Energy Commission and certified by the manufacturer are located at the following URL:

http://www.energy.ca.gov/title24/equipment_cert/imv/

4.6.5 Dwelling Unit Ventilation Rate (Section 4 of ASHRAE 62.2)

Dwelling unit ventilation systems may operate continuously or on a short-term basis. If fan operation is not continuous, the average ventilation rate over any three-hour period must be greater than or equal to the Q_{fan} value calculated using the equations in this section.

ASHRAE 62.2 provides for scheduled ventilation and real-time control, but these control approaches require "equivalent exposure" calculations using methods in Normative Appendix C, and complex controls would be required to operate the fan.

Equations for calculating Q_{fan} (the required mechanical ventilation rate) for both single- and multifamily buildings are listed below. Single-family detached dwelling units and attached dwelling units not sharing ceilings or floors with other dwelling units, occupiable spaces, public garages, or commercial spaces (e.g. duplexes and townhomes) are allowed to take credit for the building infiltration in the calculations as described below. Use of a building infiltration credit is not applicable to calculation of the required dwelling unit mechanical ventilation for multifamily dwelling units.

A new aspect of the ventilation calculations for the 2019 standards is that the building infiltration rate (Q_{inf}) varies by climate zone (Table 4-14) and building height. Therefore, the value for Q_{fan} for a single-family dwelling or townhome will also vary based on climate zone and building height.

When the performance compliance approach is used, the compliance software completes all the calculations given in Equations 4-1, 4-2, 4-3, and 4-4, and Q_{fan} is reported on the CF1R. If the prescriptive compliance approach is used, the Data

Registry will perform the calculations, and the value for Q_{fan} will be recorded on the CF1R.

4.6.5.1 Total Ventilation Rate (Q_{tot})

The total ventilation rate is the combined volume of ventilation air provided by infiltration and the mechanical ventilation provided from fans, as follows:

$$Q_{tot} = 0.03A_{floor} + 7.5(N_{br} + 1) \quad \text{Equation 4-1}$$

Where:

Q_{tot} = total required ventilation rate (CFM)

A_{floor} = conditioned floor area (ft²)

N_{br} = number of bedrooms (not less than one)

For multifamily units, the installed ventilation system must deliver the total ventilation rate Q_{tot} calculated from Equation 4-1.

4.6.5.2 Infiltration Rate (Q_{inf})

For single-family homes, when determining the required dwelling unit mechanical ventilation airflow rate (Q_{fan} in Equation 4-4), the calculated value for estimated infiltration rate (Q_{inf} in Equation 4-2) is deducted from the value of Q_{tot} (determined by Equation 4-1). The calculated value for estimated infiltration rate depends on the building leakage, building height, and the weather and shielding factor, which varies by climate zone (Table 4-14). A default envelope leakage value of 2 ACH₅₀ is mandatory for the fan sizing calculations unless a blower door measurement is performed that determines a leakage rate below 2 ACH₅₀. Leakage in ACH₅₀ must be converted to CFM₅₀ for use in subsequent calculations. Conversion of 2 ACH₅₀ is shown in Equation 4-2.

$$Q_{50} = V_{du} \times 2 \text{ ACH}_{50} / 60 \quad \text{Equation 4-2}$$

Where:

Q_{50} = leakage rate at 50 Pa, CFM

V_{du} = dwelling unit conditioned volume, ft³

ACH_{50} = air changes per hour at 50 Pa (0.2 inch water)

V_{du} can be approximated by multiplying the average ceiling height by the dwelling conditioned floor area. If the field-verified value for ACH₅₀ is less than 2, then the verified value is used in Equation 4-2 instead of 2.

The effective annual infiltration rate (Q_{inf}), is calculated using the weather/shielding factor (wsf) for the applicable climate zone and the building height. See Table 4-14 below and Standards Table 150.0-D for values for wsf.

$$Q_{inf} = 0.052 \times Q_{50} \times wsf \times [H/H_r]^2 \text{ (CFM)} \quad \text{Equation 4-3}$$

Where:

Q_{inf} = effective annual infiltration rate, CFM

Q_{50} = leakage rate at 50 Pa, CFM

wsf = weather and shielding factor from Table 4-14

H = vertical distance between the lowest and highest above-grade points within the pressure boundary

H_r = reference height = 8.2 ft

The number of stories multiplied by the average ceiling height (as entered in compliance software) provides sufficient accuracy for determining H .

Table 4-14: Weather and Shielding Factors by Climate Zone

CZ	WSF	CZ	WSF
1	0.56	9	0.39
2	0.49	10	0.42
3	0.54	11	0.50
4	0.48	12	0.51
5	0.52	13	0.45
6	0.45	14	0.58
7	0.40	15	0.45
8	0.36	16	0.44

4.6.5.3 Required Mechanical Ventilation Rate (Q_{fan})

The required mechanical ventilation rate, Q_{fan} is the total outside airflow required to be supplied to (or total indoor air required to be exhausted from) the building by fans.

Balanced ventilation system types must provide an average of the supply and exhaust airflows that is greater than or equal to Q_{fan} .

Q_{fan} is calculated using Equation 4-4 below, which uses the values for Q_{tot} and Q_{inf} determined above. Equation 4-4 accounts for reduced exterior wall leakage area in attached units (e.g. townhomes and duplexes). Equation 4-4 also accounts for the differences in ventilation effectiveness of balanced systems compared to exhaust/supply (unbalanced) systems due to varying dwelling infiltration leakage rates. If Q_{fan} is less than 10 CFM, then no fan is required.

$$Q_{fan} = Q_{tot} - \Phi (Q_{inf} \times A_{ext}) \quad \text{Equation 4-4}$$

Where:

Q_{total} = total required ventilation rate (CFM)

Q_{inf} = effective annual average infiltration rate (CFM)

$\phi = 1$ for balanced ventilation systems or Q_{inf}/Q_{tot} for other system types

$A_{ext} = 1$ for single-family detached homes. For attached dwelling units not sharing ceilings or floors with other dwelling units, occupiable spaces, public garages, or commercial spaces (e.g. duplexes and townhomes), A_{ext} is the ratio of exterior envelope surface area that is not attached to garages or other dwelling units to total envelope surface area.

For multifamily dwelling units, $Q_{fan} = Q_{tot}$.

Example 4-11 – Required Ventilation

Question:

What is the required continuous ventilation rate for a three-bedroom, 1,800 ft² townhouse located in Climate Zone 8 that has 9-foot ceilings, and where 25% of the exterior wall surface area adjoins another unit? Ventilation is provided by a bathroom exhaust fan. No extraordinary measures have been taken to seal the building.

Answer:

Equation 4-1 yields a total ventilation rate of 84 CFM

$$Q_{tot} = 0.03A_{floor} + 7.5(N_{br} + 1) = 0.03(1800) + 7.5(3 + 1) = 84 \text{ CFM}$$

The volume is $1,800 \times 9 = 16,3200 \text{ ft}^3$. Solving for Equation 4-2 results in a leakage rate of 543 CFM

$$Q_{50} = V_{du} \times 2 \text{ ACH}_{50} / 60 = 16,300 \times 2/60 = 540 \text{ CFM}$$

Using Equation 4-3: $Q_{inf} = 0.052 \times Q_{50} \times wsf \times [H/H_r]^2 = 0.053 \times 540 \times 0.36 \times (18/8.2)^{0.4} = 14 \text{ CM}$

And applying Equation 4-4, the mechanical ventilation system must move 82 CFM.

$$Q_{fan} = Q_{tot} - Q_{inf}/Q_{tot} (Q_{inf} \times A_{ext}) = 84 - 23/84(23 \times (1-0.25)) = 82 \text{ CFM}$$

Due to the reduction in infiltration resulting from reduced exterior wall area and to the use of an exhaust fan instead of a balanced system, the effective infiltration credit is only 2 CFM.

Example 4-12

Question:

The two-story house I am building in Climate Zone 12 has a floor area of 2,240 ft² and four bedrooms. I am using an HRV that delivers 80 CFM of outdoor air and exhausts 90 cfm of indoor air. My calculations come out to 86 CFM. Can I use this system?

Answer:

No. For balanced systems, the supply and exhaust airflows can be averaged, and in this case, they average 85 CFM, which is slightly less than the required 86 CFM.

The nominal rating of a fan can be different than what it actually delivers when installed and connected to ductwork, so designers should always include a safety margin when sizing equipment. The length and size of ducting should be used to calculate the pressure drop. This is why dwelling unit ventilation rates must be verified by a HERS Rater.

Example 4-13

Question:

A 2,300 ft² house has exhaust fans running continuously in two bathrooms, providing a total exhaust flow rate of 90 CFM, but the requirement is 98 CFM. What are the options for providing the additional 8 CFM?

Answer:

Option 1: The required additional CFM could be provided either by increasing the size of either or both exhaust fans such that the combined airflow exceeds 98 CFM.

Option 2: Another solution would be to use a balanced system, which may reduce the airflow requirement to below 90 CFM. Adding another 8 CFM fan is not an acceptable solution.

Example 4-14

Question:

A CFI system is connected to the return air plenum of a furnace such that when operating, 10% of the air supplied by the furnace is outdoor air. The CFI control limits furnace fan operation to 30 minutes of every hour. If the house requires 100 CFM of continuous ventilation air, what volume of air must the furnace deliver?

Answer:

Since the furnace operates half the time, the volume of outside air delivered when it is operating must be $2 \times 100 = 200$ CFM. Therefore, the furnace must be able to deliver $200/0.1 = 2,000$ CFM.

Example 4-15

Question:

Can an exhaust fan be used to supplement ventilation air provided by a CFS system?

Answer:

Yes. In the example above, if an exhaust fan is operated continuously to deliver 50 CFM, then the volume of air required of the CFI system is reduced to 100 CFM, or an average of 50 CFM over the hour such that the sum of ventilation air delivered averages 100 CFM. A 1,000 CFM furnace providing 10% outside air could be used in this case. Even though such a combined ventilation system is partially balanced, it would not qualify as a balanced system in the calculation of Q_{fan} .

Example 4-16

Question:

I want to provide controls that disable the ventilation system so it does not bring in outside air during the hottest two hours of the day, and the calculations show I need 80 CFM continuous. How large must my fan be?

Answer:

If the average rate over three hours is 80 CFM and the fan only operates one hour, then it must be capable of delivering $3 \times 80 = 240$ CFM. ASHRAE 62.2 does not allow averaging ventilation over more than a three-hour period.

4.6.5.4 Control and Operation

From ASHRAE 62.2, Section 4.4, Control and Operation. A readily accessible manual ON-OFF control, including but not limited to a fan switch or a dedicated branch-circuit overcurrent device, shall be provided. Controls shall include text or an icon indicating the system's function.

Exception: For multifamily dwelling units, the manual ON-OFF control shall not be required to be readily accessible.

From Standards Section 150.0(o)11: Compliance with ASHRAE 62.2 Section 4.4 (Control and Operation) shall require manual switches associated with dwelling unit ventilation systems to have a label clearly displaying the following text, or equivalent text: "This switch controls the indoor air quality ventilation for the home. Leave it on unless the outdoor air quality is very poor."

ASHRAE 62.2 requires that the ventilation system have an override control that is accessible to the occupants. The control must be capable of being accessed quickly and easily by the occupants. It can be a labeled wall switch or a circuit breaker located in the electrical panel, or it may be integrated into a labeled wall-mounted control. It cannot be buried in the insulation in the attic or inside the installed ventilation fan cabinet. The occupant must have easy access to modify the fan control settings or turn off the system, if necessary.

For multifamily dwelling units, the manual ON-OFF control is not required to be readily accessible to the dwelling unit occupant(s). Instead, the ventilation control may be located such that it is readily accessible to the person in charge of the multifamily building maintenance. This control strategy may be appropriate for multifamily buildings that use unbalanced (supply-only or exhaust-only) system types for which the Energy Standards require that all the ventilation systems in the building operate continuously. Continuous operation of all ventilation fans in the building tends to minimize ventilation fan-induced pressure differences between adjoining dwellings, thus reducing the leakage of transfer air between dwelling units. Transfer airflows that originate in one dwelling unit may adversely affect the indoor air quality of the other dwelling units in the building if the transfer air contains pollutants such as tobacco smoke and PM_{2.5} from kitchen range cooking.

Dwelling unit ventilation systems may operate continuously, or if fan operation is not continuous, the average ventilation rate over any three-hour period must be greater than or equal to the minimum dwelling unit ventilation rate calculated as described in Section 4.6.5 above.

Bathroom exhaust fans may serve a dual purpose to provide whole-dwelling unit ventilation operating at a low constant airflow rate and to provide local demand controlled ventilation at a higher "boost" airflow rate, when needed. For these system types, the continuous whole-dwelling unit airflow operation must have an ON/OFF override, which may be located in the bathroom or in a remote accessible location. The "boost" function is controlled by a separate wall switch located in the bathroom or by a motion sensor or humidistat located in the bathroom.

Time-of-day timers or duty-cycle timers can be used to control intermittent dwelling unit ventilation. Manual crank timers cannot be used, since the system must operate automatically without intervention by the occupant. Some controls "look back" over a set time interval to see if the CFI system air handler has already operated for heating or cooling before it turns on the air handler for ventilation-only operation.

See Section 4.6.4 for additional information about Energy Commission approval of ventilation controls.

Example 4-17 – Control Options

Question:

A bathroom exhaust fan is used to provide dwelling unit ventilation for a house. The fan is designed to be operated by a typical wall switch. Is a label on the wall plate necessary to comply with the requirement that controls be "appropriately labeled"?

Answer:

Yes. Since the fan is providing the required dwelling unit ventilation, a label is needed to inform the occupant that this switch controls the indoor air quality ventilation for the home, and directs the occupant to leave it on unless the outdoor air quality is very poor. If the exhaust fan were serving only the local exhaust requirement for the bathroom, then a label would not be required.

Example 4-18 – Thermostatic Control

Question:

Ventilation air is provided whenever the air handler operates via a duct run connecting the return side of the central air handler to the outdoors. The system is estimated to run on calls for heating and cooling about 40 percent of the time, averaged over the year. If it is assumed that the air handler runs only 25 percent of the time, and the airflow is sized accordingly, can the system be allowed to run under thermostatic control?

Answer:

No. A system under thermostatic control will go through periods with little or no operation when the outdoor temperature is near the indoor set point, or if the system is in setback mode. An intermittently operating ventilation system must be controlled by a timer that will cycle at least once every three hours to assure that adequate ventilation is provided regardless of outdoor conditions. Alternatively, a more complex control may be used if it complies with the requirements in ASSHRAE 62.2 Appendix C. These systems must be approved by the Energy Commission before being allowed for use for compliance with the required dwelling unit ventilation.

Cycle timer controls are available that keep track of when (and for how long) the system operates to satisfy heating/cooling requirements in the home. These controls turn on the central fan to provide additional ventilation air when heating/cooling operation of the central fan has not already operated for a long enough period to provide the required ventilation. When choosing cycle timer controls for compliance, it is necessary to use models that have been approved by the Energy Commission for use for compliance with dwelling unit mechanical ventilation.

4.6.6 Dwelling Unit Mechanical Ventilation Energy Consumption

For builders using the performance compliance approach, the energy use of fans (other than CFI fans) installed to meet the dwelling unit ventilation requirement is usually not an issue. The reason is the standard design W/CFM is set equal to the proposed design W/CFM up to an energy use level sufficient to accommodate most well-designed ventilation systems. Also, the standard design dwelling unit ventilation system airflow rate is set equal to the proposed design dwelling unit ventilation system airflow rate, so there is no energy penalty or credit for most systems. For balanced heat recovery or energy recovery ventilators (HRVs/ERVs), the HVI-rated recovery efficiency can be input to the performance compliance software to account for the heat recovery benefit, which helps offset higher fan energy use.

The fan efficacy of the central air handler used for a CFI ventilation system must conform to the same fan watt draw (W/CFM) limit as for cooling systems in all climate zones as verified by a HERS Rater in accordance with the diagnostic test protocols given in RA3.3. The RA3.3 verification of CFI systems determines the W/CFM of the total central system airflow, not the W/CFM of the ventilation airflow.

The Energy Standards do not regulate the energy use of ventilation fans installed for other purposes, such as local exhaust.

4.6.6.1 Central Fan-Integrated Ventilation Systems – Watt Draw

§150.1(f)10

CFI system automatic controls must operate the central system air handler fan (generally part of every hour of the year) to draw in and distribute ventilation air throughout the dwelling, even when there is no heating or cooling required. The Energy Standards prohibit CFI systems from operating continuously. Because the CFI ventilation control increases the central system air handler fan run time significantly, and because typical central system air handler fan and duct systems

require a large amount of power, a CFI ventilation system can use a large amount of electricity annually.

The fan efficacy of CFI systems must be verified using the same methods as required for furnaces and air handlers. (See Reference Residential Appendix RA3.3.) The central system air handler must be operating in ventilation mode with the outdoor air damper open and with ventilation air flowing into the return plenum from outside the building. Furthermore, the airflow that must be measured is the total airflow through the air handler (system airflow), which is the sum of the return airflow, and the outside air ducted to the return plenum (ventilation airflow). To pass the test, the watt draw must be less than or equal to 0.45 W/CFM for furnaces, and 0.58 W/CFM for air handlers that are not gas furnaces, or 0.62 W/CFM for small ductm high velocity systems.

4.6.6.2 Other Dwelling Unit Ventilation Systems – Watt Draw

There are no prescriptive or mandatory requirements for maximum fan energy (watt draw) for dwelling unit ventilation systems other than CFI systems.

When using the performance approach, you have the option of accepting the default minimum dwelling unit ventilation airflow rate and a watt draw value of 0.25 W/CFM, which is typical of continuous exhaust fans that meet the 1 sone requirement.

Otherwise, if the installed fan has a different airflow and fan efficacy, the actual airflow rate and fan watt draw of the fan must be input. Values for airflow and fan W/CFM information may be available from the HVI directory at the following URL.

https://www.hvi.org/proddirectory/CPD_Reports/section_1/index.cfm

If HVI does not list fan energy for the installed model, use information from the manufacturer's published documentation. When fan energy is listed as CFM/W instead of W/CFM, it is necessary to invert the value to provide W/CFM as input to the compliance software (for example: 4 CFM/ W = 1/4 W/CFM = 0.25 W/CFM). Installation of a dwelling unit ventilation system with a fan watt draw greater than 1.2 W/CFM of ventilation airflow will affect the results of the performance compliance calculation. Values less than 1.2 W/CFM are compliance-neutral (standard design = proposed design). The compliance software will simulate dwelling unit ventilation using the ventilation system CFM and W/CFM for the proposed design. If the builder specifies a system with heat recovery, he or she inputs the recovery efficiency of the proposed system, and the compliance software uses it in the proposed design to calculate the heat recovery effect of the dwelling unit ventilation. Ventilation heat recovery is never used in the standard design.

4.6.7 Local Exhaust (Section 5 of ASHRAE 62.2)

From ASHRAE 62.2,

5.1 Local Mechanical Exhaust. A local mechanical exhaust system shall be installed in each kitchen and bathroom. Nonenclosed kitchens shall be provided with a demand-controlled mechanical exhaust system meeting the requirements of Section 5.2. Each local ventilation system for all other kitchens and bathrooms shall be either one of the following two:

a. a demand-controlled mechanical exhaust system meeting the requirements of Section 5.2 or

b. a continuous mechanical exhaust system meeting the requirements of Section 5.3.

Exception: Alternative Ventilation. Other design methods may be used to provide the required exhaust rates when approved by a licensed design professional.

5.2 Demand-Controlled Mechanical Exhaust. A local mechanical exhaust system shall be designed to be operated as needed.

5.2.1 Control and Operation. Demand-controlled mechanical exhaust systems shall be provided with at least one of the following controls:

a. A readily accessible occupant-controlled ON-OFF control.

b. An automatic control that does not impede occupant ON control.

5.2.2 Ventilation Rate. The minimum airflow rating shall be at least the amount indicated in Table 5.1.

5.3 Continuous Mechanical Exhaust. A mechanical exhaust system shall be installed to operate continuously. The system may be part of a balanced mechanical system. See Chapter 10 of ASHRAE Guideline 24 for guidance on selection of methods.

5.3.1 Control and Operation. A readily accessible manual ON-OFF control shall be provided for each continuous mechanical exhaust system. The system shall be designed to operate during all occupiable hours.

Exception: For multifamily dwelling units, the manual ON-OFF control shall not be required to be readily accessible.

5.3.2 Ventilation Rate. The minimum delivered ventilation shall be at least the amount indicated in Table 5.2 during each hour of operation.

From ASHRAE 62.2 - Table 5-1 Demand-Controlled Local Ventilation Exhaust Airflow Rates.

Application	Airflow
Enclosed Kitchen	<ul style="list-style-type: none"> • Vented range hood (including appliance-range hood combinations): 100 CFM (50 L/s) • Other kitchen exhaust fans, including downdraft: 300 CFM (150 L/s) or a capacity of 5 ach
Non-Enclosed Kitchen	<ul style="list-style-type: none"> • Vented range hood (including appliance-range hood combinations): 100 CFM (50 L/s) • Other kitchen exhaust fans, including downdraft: 300 CFM (150 L/s)
Bathroom	50 CFM (25 L/s)

From ASHRAE 62.2 - TABLE 5.2 Continuous Local Ventilation Exhaust Airflow Rates

Application	Airflow
Enclosed Kitchen	5 ACH, based on kitchen volume
Bathroom	20 CFM (10 L/s)

Local exhaust (sometimes called *spot ventilation*) has long been required for bathrooms and kitchens to remove moisture and odors at the source. Building codes have required an operable window or an exhaust fan in bathrooms for many years and have generally required kitchen exhaust either directly through a fan or indirectly through a recirculating range hood and an operable window. The Energy Standards recognize the limitations of these indirect methods of reducing moisture and odors and requires that these spaces be mechanically exhausted directly to outdoors, even if windows are present. Moisture condensation on indoor surfaces are a leading cause of mold and mildew in buildings. The occurrence of asthma is also associated with high interior relative humidity. Therefore, it is important to exhaust the excess moisture from bathing and cooking directly at the source.

The Energy Standards require that each kitchen and bathroom have an exhaust fan. Generally, this will be a dedicated exhaust fan in each room that requires local exhaust, although ventilation systems that exhaust air from multiple rooms using a duct system connected to a single exhaust fan are allowed as long as the minimum local exhaust requirement is met in all rooms served by the system. The standards define kitchens as any room containing cooking appliances, and bathrooms any room containing a bathtub, shower, spa, or other similar source of moisture. A room containing only a toilet is not required to have an exhaust fan; ASHRAE 62.2 assumes there is an adjacent bathroom with local exhaust.

Building codes may require that fans used for kitchen range hood exhaust ventilation be safety-rated by UL or some other testing agency for the particular location and/or application. Typically, these requirements address fire safety issues of fans placed

within an area defined by a set of lines at 45° outward and upward from the cooktop. Few bathroom exhaust fans will have this rating, so they cannot be used in these locations.

Example 4-19 – Local Exhaust Required for Toilet**Question:**

I am building a house with 2½ baths. The half-bath consists of a room with a toilet and sink. Is local exhaust required for the half bath?

Answer:

No. Local exhaust is required only for bathrooms, which are defined by the Energy Standards as rooms with a bathtub, shower, spa or some other similar source of moisture. This does not include a simple sink for occasional hand washing.

Example 4-20**Question:**

The master bath suite in a house has a bathroom with a shower, spa and sinks. The toilet is in a separate, adjacent room with a full door. Where do I need to install local exhaust fans?

Answer:

The standards require local exhaust only in the bathroom, not the separate toilet room.

4.6.7.1 Demand-Controlled (Intermittent) Local Exhaust

The Energy Standards require that local exhaust fans be designed to be operated by the occupant. This usually means that a wall switch or some other control is accessible and obvious. There is no requirement to specify where the control or switch needs to be located, but bathroom exhaust fan controls are generally located next to the light switch, and kitchen exhaust fan controls are generally integrated into the range hood or mounted on the wall or counter adjacent to the range hood.

Bathrooms can use a variety of exhaust strategies. They can use ceiling-mounted exhaust fans or may use a remotely mounted fan ducted to two or more exhaust grilles. Demand-controlled local exhaust can be integrated with the dwelling unit ventilation system to provide both functions. Kitchens can have range hood exhaust fans, down-draft exhausts, ceiling- or wall-mounted exhaust fans, or pickups for remote-mounted inline exhaust fans. Generally, HRV/ERV manufacturers do not allow exhaust ducting from the kitchen because of the heat, moisture, grease, and particulates that should not enter the heat exchange core. Building codes require kitchen exhaust fans to be connected to metal ductwork for fire safety.

Example 4-21 – Ducting Kitchen Exhaust to the Outdoors

Question:

How do I know what kind of duct I need to use? I've been using recirculating hoods my entire career, now I need to vent to the outdoors. How do I do it?

Answer:

A kitchen range hood or downdraft duct is generally a smooth metal duct that is sized to match the outlet of the ventilation device. It is often a six-inch or seven-inch-round duct, or the range hood may have a rectangular discharge. If it is rectangular, the fan will typically have a rectangular-to-round adapter included. Always use a terminal device on the roof or wall that is sized to be at least as large as the duct. Try to minimize the number of elbows used.

Example 4-22

Question:

How do I know what the requirements are in my area?

Answer:

Ask your code enforcement agency for that information. Some enforcement agencies will accept metal flex; some will not.

A. Control and Operation for Intermittent Local Exhaust

The choice of control is left to the designer. It can be a manual switch or automatic control like an occupancy sensor. Some exhaust fans have multiple speeds, and some fan controls have a delay-off function that operates the exhaust fan for a set time after the occupant leaves the bathroom. New control strategies continue to come to the market. The only requirement is that there is a control. Title 24, Part 11 may specify additional requirements for the control and operation of intermittent local exhaust.

B. Ventilation Rate for Demand-Controlled Local Exhaust

A minimum exhaust airflow of 100 CFM is required for vented kitchen range hoods, and 300 CFM or 5 ACH is required for other kitchen exhaust fans. A minimum exhaust airflow of 50 CFM is required for bathroom fans.

The 100 CFM requirement for the range hood or microwave/hood combination is the minimum to adequately capture the moisture, particulates, and other products of cooking and/or combustion. Only in kitchens that are enclosed, the exhaust requirement can also be met with either a ceiling or wall-mounted exhaust fan or with a ducted fan or ducted ventilation system that can provide at least five air changes of the kitchen volume per hour. Recirculating range hoods that do not exhaust pollutants to the outside cannot be used to meet the requirements of

ASHRAE Standard 62.2 unless paired with an exhaust system that can provide at least five air changes of the kitchen volume per hour.

The 2019 Title 24 Part 6 standards require verification that range hoods are HVI-certified to provide at least one speed setting at which they can deliver at least 100 CFM at a noise level of 3 sones or less. Verification must be in accordance with the procedures in *Reference Residential Appendix RA3.7.4.3*. Range hoods that have a minimum airflow setting exceeding 400 CFM are exempt from the noise requirement. HVI listings are available at:

https://www.hvi.org/proddirectory/CPD_Reports/section_1/index.cfm

ASHRAE Standard 62.2 limits exhaust airflow when atmospherically vented combustion appliances are located inside the pressure boundary. This is particularly important to observe when large range hoods are installed. Refer to Section 4.6.8.4 below for more information.

Example 4-23 – Ceiling or Wall Exhaust vs Demand-Controlled Range Hood in an Enclosed Kitchen

Question:

I am building a house with an enclosed kitchen that is 12 ft. x 14 ft. with a 10 ft. ceiling. What size ceiling exhaust fan or range hood fan is required?

Answer:

If a range hood exhaust is not used, either 300 CFM or 5 ACH minimum airflow is required. The kitchen volume is 12 ft. x 14 ft. x 10 ft. = 1,680 ft³. Five air changes are a flow rate of 1,680 ft³ x 5/ hr. ÷ 60 min/hr = 140 CFM. So, this kitchen must have a ceiling or wall exhaust fan of 140 CFM. Otherwise, a vented range hood fan that provides at least 100 CFM is required.

4.6.7.2 Continuous Local Exhaust

The Energy Standards allow the designer to install a local exhaust system that operates without occupant intervention continuously and automatically during all occupiable hours. Continuous local exhaust is generally specified when the local exhaust ventilation system is combined with a continuous dwelling unit ventilation system. For example, if the dwelling unit ventilation is provided by a continuously operating exhaust fan located in the bathroom, this fan may also satisfy the local exhaust requirement for that bathroom, provided the fan provides airflow greater than or equal to the minimum continuous local ventilation airflow rate. Continuous local exhaust may also be part of a pickup, or an interior grille, for a remote fan or HRV/ERV system.

Continuously operating bathroom fans must operate at a minimum of 20 CFM. Continuously operating kitchen fans are permitted only for enclosed kitchens. Refer to Tables 5.1 and 5.2 in ASHRAE 62.2 for other local demand controlled and continuous exhaust requirements.

Example 4-24 – Continuous Kitchen Exhaust

Question:

A new house has an open-design, 12 ft. x18 ft. ranch kitchen with 12 ft. cathedral ceilings. What airflow rate will be required for a continuous exhaust fan?

Answer:

A continuous exhaust fan cannot be used in nonenclosed kitchens. A vented range hood must be provided.

4.6.8 Other Requirements (Section 6 of ASHRAE 62.2)

4.6.8.1 Adjacent Spaces and Transfer Air

From ASHRAE 62.2,

6.1 Adjacent Spaces and Transfer Air. Measures shall be taken to minimize air movement across envelope components to dwelling units from adjacent spaces such as garages, unconditioned crawlspaces, unconditioned attics, and other dwelling units. Pressure boundary wall, ceiling, and floor penetrations shall be sealed, as shall any vertical chases adjacent to dwelling units. Doors between dwelling units and common hallways shall be gasketed or made substantially airtight.

Supply and balanced ventilation systems shall be designed and constructed to provide ventilation air directly from the outdoors.

6.1.1 Compliance for Attached Dwelling Units. One method of demonstrating compliance with Section 6.1 shall be to verify a leakage rate below a maximum of 0.3 CFM per ft² (150 L/s per 100 m²) of the dwelling unit envelope area (i.e., the sum of the area of walls between dwelling units, exterior walls, ceiling, and floor) at a test pressure of 50 Pa by a blower door test conducted in accordance with either ANSI/ASTM-E779 or ANSI/ASTM-E1827. The test shall be conducted with the dwelling unit as if it were exposed to outdoor air on all sides, top, and bottom by opening doors and windows of adjacent dwelling units.

ASHRAE Standard 62.2 requires that the air used for ventilation come from the outdoors. Air may not be drawn in as transfer air from other spaces that are outside the occupiable space of the dwelling unit, or from between dwelling units and corridors. This is to prevent airborne pollutants originating in those other spaces from contaminating the dwelling unit. For example, drawing ventilation air from the garage could introduce VOCs or pesticides into the indoor air. Drawing ventilation air from an unconditioned crawlspace could cause elevated allergen concentrations in the dwelling such as mold spores, insects, or rodent allergens. Likewise, drawing air from an adjacent dwelling could introduce unwanted contaminants such as cooking odors or cigarette smoke.

Standards Section 150.0(o)1E requires HERS verification compliance with a maximum of 0.3 CFM/ft² dwelling unit enclosure leakage when either supply ventilation is used or exhaust ventilation is used. The protocol for the blower door test is given in Reference Residential Appendix RA3.8. See also Section 4.6.3.2 in this chapter for more information about multifamily dwelling unit compartmentalization.

In addition to designing the ventilation system to draw air from the outdoors, the standard also requires that measures be taken to prevent air movement between adjacent dwelling units and between the dwelling unit and other nearby spaces, such as garages. The measures can include air sealing of envelope components, pressure management, and use of airtight recessed light fixtures. The measures must apply to adjacent units above and below, as well as side by side.

Air sealing must include pathways in vertical components such as demising walls and walls common to the unit and an attached garage, and in horizontal components such as floors and ceilings. Pipe and electrical penetrations are examples of pathways that require sealing.

4.6.8.2 Instructions and Labeling

From ASHRAE 62.2, Section 6.2, Instructions and Labeling.

Information on the ventilation design and/or ventilation systems installed, instructions on their proper operation to meet the requirements of this standard, and instructions detailing any required maintenance (similar to that provided for HVAC systems) shall be provided to the owner and the occupant of the dwelling unit. Controls shall be labeled as to their function (unless that function is obvious, such as toilet exhaust fan switches).

From Standards Section 150.0(o)1I:

Compliance with ASHRAE 62.2 Section 4.4 (Control and Operation) shall require manual switches associated with dwelling unit ventilation systems to have a label clearly displaying the following text, or equivalent text: "This switch controls the indoor air quality ventilation for the home. Leave it on unless the outdoor air quality is very poor."

Field studies have shown that switches for exhaust fans do not have the required labels, and that many homeowners do not understand the importance of continuous operation of the ventilation fans for maintaining indoor air quality. Standards Section 10-103(b)4 require the builder to leave in the building, for the building owner at occupancy, a description of the quantities of outdoor air that the ventilation system(s) are designed to provide to the conditioned space of the building and instructions for proper operation and maintenance of the ventilation system.

Because the concept of a designed dwelling unit ventilation system may be new to many occupants, the standards section requires that ventilation system controls be

labeled as to function. One acceptable option is to affix a label to the electrical panel that provides some basic system operation information.

4.6.8.3 Clothes Dryers

From ASHRAE 62.2, Section 6.3, Clothes Dryers.

Clothes dryers shall be exhausted directly to the outdoors. Exception: Condensing dryers plumbed to a drain.

All laundry rooms must be built with a duct to the outdoors, designed to be connected to the dryer. Devices that allow the exhaust air to be diverted into the indoor space to provide extra heating are not permitted. This requirement is consistent with existing clothes dryer installation and design standards.

In multifamily buildings, multiple dryer exhaust ducts can be connected to a common exhaust only when dampers are provided to prevent recirculation of exhaust air from one apartment to another.

Example 4-25 – Clothes Dryer Exhaust Diverter

Question:

I am building a home that has been purchased prior to completion. The buyer has asked for an exhaust air diverter to be installed in the dryer exhaust duct. He says that it is wasteful of heating energy to exhaust the warm humid air to the outdoors during the winter when the furnace and humidifier are working. He says that the screen on the diverter will prevent excess dust being released into the space. Can I install the device for him?

Answer:

If you do, you will not comply with the Energy Standards. The device is specifically prohibited. Significant amounts of dust are released from such devices, and the moisture in the dryer exhaust can lead to humidity problems as well, particularly in warmer climates.

4.6.8.4 Combustion and Solid-Fuel Burning Appliances

From ASHRAE 62.2, Section 6.4, Combustion and Solid-Fuel Burning Appliances

6.4.1 Combustion and solid-fuel burning appliances must be provided with adequate combustion and ventilation air and installed in accordance with manufacturers' installation instructions; NFPA 54/ANSI Z223.1, National Fuel Gas Code⁵; NFPA 31, Standard for the Installation of Oil-Burning Equipment⁶; or NFPA 211, Standard for Chimneys, Fireplaces, Vents, and Solid-Fuel Burning Appliances,⁷ or other equivalent code acceptable to the building official.

6.4.2 Where atmospherically vented combustion appliances or solid-fuel burning appliances are located inside the pressure boundary, the total net

exhaust flow of the two largest exhaust fans (not including a summer cooling fan intended to be operated only when windows or other air inlets are open) shall not exceed 15 CFM per 100 ft² (75 L/s per 100 m²) of occupiable space when in operation at full capacity. If the designed total net flow exceeds this limit, the net exhaust flow must be reduced by reducing the exhaust flow or providing compensating outdoor air. Gravity or barometric dampers in nonpowered exhaust makeup air systems shall not be used to provide compensating outdoor air. Atmospherically vented combustion appliances do not include direct-vent appliances. Combustion appliances that pass safety testing performed according to ANSI/BPI-1200, Standard Practice for Basic Analysis of Buildings, shall be deemed as complying with Section 6.4.2.

ASHRAE Standard 62.2 requires that the vent system for combustion appliances be properly installed, as specified by the instructions from the appliance manufacturer and by the California Building Code. Compliance with the venting requirements will involve determining the type of vent material to be used, the sizing of the vent system, and vent routing requirements.

ASHRAE Standard 62.2 includes a provision intended to prevent back drafting, where one or more large exhaust fans are installed in a home with atmospherically vented or solid fuel appliances. If the two largest exhaust fans have a combined capacity that exceeds 15 CFM/100 ft² of floor area, then makeup air must be provided. This provision applies only when the atmospherically vented appliance is inside the pressure boundary of the house and does not include a summer cooling fan that is designed to be operated with the windows open. Direct-vent appliances are not considered “atmospherically vented.”

The two largest exhaust fans are normally the kitchen range hood and the clothes dryer (if located inside the dwelling unit pressure boundary). Large-range hoods, particularly downdraft range hoods, can have capacities of 1,000 CFM or more.

A problem with this requirement can be solved in one of three ways. First, all atmospherically vented combustion appliances can be moved outside the pressure boundary of the house (to the garage or other similar space). Second, the flow rate of one or more of the fans can be reduced so that the combined flow is less than 15 CFM/100 ft². Finally, makeup air can be provided to offset the net exhaust rate.

Example 4-26 – Large Exhaust Fan

Question:

I am building a 3,600 ft² custom home that has four bedrooms. The kitchen will have a high-end range hood that has three speeds, nominally 1,000 CFM, 1,400 CFM and 1,600 CFM. The house will include an atmospherically vented gas water heater located in the basement. If I am using a central exhaust fan for the dwelling unit ventilation of 75 CFM, and there is a clothes dryer installed, how much compensating outdoor airflow (makeup air) is needed?

Answer:

You must use the high-speed value for the range hood of 1,600 CFM. The clothes dryer will have a flow that is assumed to be 150 CFM for sizing purposes. These two flows must be added together for a total exhaust capacity of 1,750 CFM. Since the dwelling unit ventilation fan is not one of the two largest exhaust fans, it does not figure into the makeup air calculation. Using the equation above, there must be at least 1,750 CFM – $(15 \text{ CFM} \times 3,600 \text{ ft}^2 / 100 \text{ ft}^2) = 1,210 \text{ CFM}$ of makeup airflow.

Example 4-27

Question:

The same custom house will have the water heater located in the garage instead of the basement. Does that change anything?

Answer:

Garages (and attics) are normally located outside the pressure boundary, so makeup air is not required. If the garage is inside the pressure boundary, makeup air is required, and the answer would be the same as 4-24.

Example 4-28

Question:

For this house, I need to keep the water heater in the basement. What are my options that would avoid the requirement to provide makeup air?

Answer:

There are several things you could do. First, you could use a direct vent water heater that would also provide higher fuel efficiency. You could use a lower capacity range hood, one that is less than 390 CFM $(15 \text{ CFM} \times 3,600 \text{ ft}^2 / 100 \text{ ft}^2 - 150 \text{ CFM})$. Use of supply-only dwelling unit ventilation would allow the hood capacity to increase to 465 CFM $(15 \text{ CFM} \times 3,600 \text{ ft}^2 / 100 \text{ ft}^2 - 150 \text{ CFM} + 75 \text{ CFM})$. There are also range hoods available in the commercial market that provide makeup air.

4.6.8.5 Garages

From ASHRAE 62.2, Section 6.5.1, Garages.

When an occupiable space adjoins a garage, the design must prevent migration of contaminants to the adjoining occupiable space. Air seal the walls, ceilings, and floors that separate garages from occupiable space. To be considered air-sealed, all joints, seams, penetrations, openings between door assemblies and their respective jambs and framing, and other sources of air leakage through wall and ceiling assemblies separating the garage from the residence and its attic area shall be caulked, gasketed, weather stripped, wrapped, or otherwise sealed to limit air movement. Doors between garages and occupiable spaces shall be gasketed or made substantially airtight with weather stripping.

Garages often contain numerous sources of contaminants. These include vehicle exhaust, gasoline, pesticides, paints and solvents, and others. The Energy Standards require that when garages are attached to the house, these contaminants be prevented from entering the house. The wall between the unit and garage (or garage ceiling in designs with living space above garages) shall be designed and constructed so that no air migrates through the wall or ceiling. The common doors and any air handlers or ducts located in the garage shall also be sealed, weatherstripped, or gasketed.

Standards Section 150.0(o) specifies that compliance with ASHRAE 62.2 Section 6.5.2 (Space Conditioning System Ducts) shall not be required. However, the applicable duct leakage verification requirements are given in Standards Sections 150.0(m)11 for newly constructed buildings, and 150.2(b)1D for alterations to systems in existing buildings. All ducted space conditioning systems in newly constructed buildings are required to pass HERS verification that duct system leaks are less than or equal to 5 percent of the system airflow rate. This requirement applies to portions of the system that may be in a garage space.

For alterations to space conditioning systems in existing buildings that have all or portions of the forced air ducts, plenums or air-handling units in the garage, Section 150.2(b)1D specifies two compliance approaches:

1. The measured system duct leakage shall be less than or equal to 6 percent of system air handler airflow as determined using the procedures in Reference Residential Appendix Section RA3.1.4.3.1.
2. All accessible leaks located in the garage space shall be sealed and verified through a visual inspection and a smoke test by a certified HERS Rater using the methods specified in Reference Residential Appendix RA3.1.4.3.5.

For additions and alterations to existing buildings, any length of new or altered duct located in the garage or any new or altered air-handling unit located in the garage triggers these duct leakage testing requirements.

Example 4-29 – Garages

Question:

In a newly constructed building, the building designer located the air handler in the garage. The main return trunk from the dwelling is connected to the air handler. Is this acceptable?

Answer:

Yes. The duct system must be leak-tested and sealed, if necessary, to have leakage no greater than 5 percent of the total fan flow.

Example 4-30

Question:

For an alteration to an existing building, the air handler is located in the dwelling unit, and a portion of the return duct is run through the garage to a bedroom above the garage. The return duct has 4 feet of length located in the garage, and this 4-foot section is being replaced. How do I test that length of the duct for leakage?

Answer:

First, test the leakage for the entire duct system to determine whether the total system duct leakage is no greater than 6 percent of the total fan flow. If the system does not meet the 6 percent target for compliance, then use the visual inspection and smoke test specified in RA3.1.4.3.5 and seal all accessible leaks in the 4-foot section of duct that is in the garage space.

4.6.8.6 Ventilation Opening Area

From ASHRAE 62.2, Section 6.6 Ventilation Opening Area.

Spaces shall have ventilation openings as listed in the following subsections. Such openings shall meet the requirements of Section 6.8.

Exception: Attached dwelling units and spaces that meet the local ventilation requirements set for bathrooms in Section 5.

6.6.1 Habitable Spaces. Each habitable space shall be provided with ventilation openings with an openable area not less than 4% of the floor area or less than 5 ft² (0.5 m²).

6.6.2 Toilets and Utility Rooms. Toilets and utility rooms shall be provided with ventilation openings with an openable area not less than 4% of the room floor area or less than 1.5 ft² (0.15 m²).

Exceptions:

- 1. Utility rooms with a dryer exhaust duct.*
- 2. Toilet compartments in bathrooms.*

The dwelling unit mechanical ventilation is intended to provide adequate ventilation to typical new homes under normal circumstances. On occasion, however, houses experience unusual circumstances where high levels of contaminants are released into the space. When this occurs, a means of providing the significantly higher levels of ventilation required to remove the contaminants is needed. Operable windows are the most likely means of providing the additional ventilation.

This section of ASHRAE Standard 62.2 requires ventilation openings in habitable spaces, toilets, and utility rooms. Ventilation openings usually mean operable windows, although a dedicated nonwindow opening for ventilation is acceptable. Spaces that meet the local exhaust requirements are exempted from this requirement.

4.6.8.7 Habitable Spaces

Habitable spaces are required to have ventilation openings with openable area equal to at least 4 percent of the space floor area (but not less than 5 ft²). Dining rooms, living rooms, family rooms, bedrooms, and kitchens are considered habitable space. Closets, crawl spaces, garages, and utility rooms are generally not. If the washer and dryer are located in an open basement that is also the family room, it would be considered habitable space.

The openings do not have to be provided by windows. They can also be provided by operable, insulated, weather-stripped panels.

Ventilation openings, which include operable windows, skylights, through-the-wall vents, window vents, or similar devices, shall be readily accessible to the occupant. This means that the occupant must be able to operate the opening without having to climb on anything. An operable skylight must have some means of being operated while standing on the floor: a push rod, a long crank handle, or an electric motor.

If a ventilation opening is covered with louvers or otherwise obstructed, the openable area is the unobstructed free area through the opening.

Example 4-31 – Ventilation Openings

Question:

I am building a house with a 14 ft. by 12 ft. bedroom. What size window do I need to install?

Answer:

It depends on the type of window. The standard requires that the openable area of the window, not the window unit, be 4 percent of the floor area, or $14 \text{ ft} \times 12 \text{ ft} \times 0.04 = 6.7 \text{ ft}^2$. The fully opened area of the window or windows must be greater than 6.7 ft². The requirement for this example can be met using two double-hung windows, each with a fully opened area of 3.35 ft². Any combination of windows whose opened areas add up to at least 6.7 ft² will meet the requirement.

Example 432 – Ventilation Opening Louvers

Question:

There are fixed wooden louvers over a window in a bedroom. The louvers have slats that are 1/8-in thick, and they are spaced 1 inch apart. What is the reduction in openable area?

Answer:

Assuming that the 1-inch spacing was measured perpendicular to the slats (the correct way), then the reduction is the slat thickness divided by the spacing, or 1/8 inch. So the credited opening area is the original opening area $\times (1 \text{ inch} - 1/8 \text{ inch})/1 \text{ inch} = 7/8$ of the original opening area.

4.6.8.8 Minimum Filtration

Compliance with ASHRAE 62.2 Sections 6.7 (Minimum Filtration) and 6.7.1 (Filter Pressure Drop) are not be required (Standards Section 150.0(o)1D). However, air filtration for mechanical systems must conform to the specifications in Standards Section 150.0(m)12. Information on air filtration requirements is given in Section 4.4.1.14 of this chapter.

4.6.8.9 Air Inlets

From ASHRAE 62.2, Section 6.8, Air Inlets.

Air inlets that are part of the ventilation design shall be located a minimum of 10 ft (3 m) from known sources of contamination such as a stack, vent, exhaust hood, or vehicle exhaust. The intake shall be placed so that entering air is not obstructed by snow, plantings, or other material. Forced air inlets shall be provided with rodent/insect screens (mesh not larger than 1/2 in. [13 mm]).

Exceptions:

1. Ventilation openings in the wall may be as close as a stretched-string distance of 3 ft (1 m) from sources of contamination exiting through the roof or dryer exhausts.

2. No minimum separation distance shall be required between windows and local exhaust outlets in kitchens and bathrooms.

3. Vent terminations covered by and meeting the requirements of the National Fuel Gas Code (NFPA 54/ANSI Z223.1)7 or equivalent.

4. Where a combined exhaust/intake termination is used to separate intake air from exhaust air originating in a living space other than kitchens, no minimum separation distance between these two openings is required. For these combined terminations, the exhaust air concentration within the intake airflow shall not exceed 10%, as established by the manufacturer.

6.8.1 Ventilation Openings.

Operable windows, skylights, through-the-wall inlets, window air inlets, or similar devices shall be readily accessible to occupants. Where openings are covered with louvers or otherwise obstructed, openable area shall be based on the free, unobstructed area through the opening.

When the ventilation system is designed with air inlets, the inlets must be located away from locations that can be expected to be sources of contamination. The minimum separation is 10 ft. Inlets include not only inlets to ducts, but windows that are needed to the opening area.

The Energy Standards list some likely sources of contaminants. For typical residential applications, the sources will include:

1. Vents from combustion appliances.

2. Chimneys.
3. Exhaust fan outlets.
4. Barbeque grills.
5. Locations where vehicles may be idling for any significant length of time.
6. Any other locations where contaminants will be generated.

The Energy Standards also require that air intakes be placed so that they will not become obstructed by snow, plants, or other material. Forced air inlets must also be equipped with insect/rodent screens, where the mesh is no larger than 1/2 inch.

4.6.9 Air-Moving Equipment (Section 7 of ASHRAE 62.2)

From ASHRAE 62.2, Section 7.1, Selection and Installation.

Ventilation devices and equipment serving individual dwelling units shall be tested in accordance with ANSI/ASHRAE Standard 51/AMCA 210, Laboratory Methods of Testing Fans for Aerodynamic Performance Rating, and ANSI/AMCA Standard 300, Reverberant Room Method for Sound Testing of Fans, and rated in accordance with the airflow and sound rating procedures of the Home Ventilating Institute (HVI) (HVI 915, Loudness Testing and Rating Procedure; HVI 916, Air Flow Test Procedure; and HVI 920, Product Performance Certification Procedure Including Verification and Challenge). Installations of systems or equipment shall be carried out in accordance with manufacturers' design requirements and installation instructions.

Equipment used to meet the dwelling unit ventilation requirements or the local exhaust ventilation requirements shall be rated to deliver the required airflow and shall have sound ratings that meet the requirements of this section.

4.6.9.1 Selection and Installation

ASHRAE Standard 62.2 requires that equipment used to comply with the standard be selected based on tested and certified ratings of performance for airflow and sound. When selecting fans for use in meeting the requirements of the standard, you must check the Home Ventilating Institute (HVI) Certified Products Directory to confirm that the equipment you select has been tested and the rated performance meets the requirements. The *HVI-Certified Products Directory* can be viewed at the following URL:

<http://www.hvi.org/proddirectory/index.cfm>.

In addition, the Energy Standards require that the fans be installed in accordance with the manufacturer's instructions. You must review the installation instructions and other literature shipped with the fan and make sure that the installation complies with those instructions.

4.6.9.2 Sound Ratings for Fans

From ASHRAE 62.2, Section 7.2, Sound Ratings for Fans.

Ventilation fans shall be rated for sound at no less than the minimum airflow rate required by this standard as noted below. These sound ratings shall be at a minimum of 0.1 in. wc (25 Pa) static pressure in accordance with the HVI procedures referenced in Section 7.1.

Exception: HVAC air handlers and remote mounted fans need not meet sound requirements. To be considered for this exception, a remote mounted fan must be mounted outside the habitable spaces, bathrooms, toilets, and hallways, and there must be at least 4 ft (1 m) of ductwork between the fan and the intake grille.

7.2.1 Dwelling-Unit Ventilation or Continuous Local Exhaust Fans. These fans shall be rated for sound at a maximum of 1.0 sone.

7.2.2 Demand-Controlled Local Exhaust Fans. Bathroom exhaust fans used to comply with Section 5.2 shall be rated for sound at a maximum of 3 sones. Kitchen exhaust fans used to comply with Section 5.2 shall be rated for sound at a maximum of 3 sones at one or more airflow settings greater than or equal to 100 CFM (47 L/s).

Exception: Fans with a minimum airflow setting exceeding 400 CFM (189 L/s) need not comply.

Standards Section 150.0(o)1G requires kitchen range hoods to be rated for sound in accordance with Section 7.2 of ASHRAE 62.2, and provides an exception to allow kitchen range hoods to be rated for sound at a static pressure determined at working speed as specified in HVI 916 Section 7.2. The static pressure at working speed may be lower than 0.1 inch w.c.

One common reason ventilation equipment may not be operated by dwelling unit occupants, particularly local exhaust fans, is the noise the fans may create. To address this, ASHRAE Standard 62.2 requires that certain fans be rated for sound and that installed fans shall have ratings below specified limits. The sound rating must be done at an airflow that is no less than the airflow that the fan must provide to meet the ventilation airflow requirement.

Because of the variables in length and type of duct and grille, there is no clearly repeatable way to specify a sound level for ventilation devices that are not mounted in the ceiling or wall surface. Consequently, air handlers, HRV/ERVs, inline fans, and remote fans are exempted from the sound rating requirements that apply to surface-mounted fans. However, to reduce the amount of fan and/or motor noise that could come down the duct to the grille, the Energy Standards sets a minimum of 4 feet of ductwork between the grille and the ventilation device. This may still produce an undesirable amount of noise for the occupant, especially if hard metal duct is used. Flexible insulated duct or a sound attenuator will reduce the transmitted sound into the space.

A. Continuous Ventilation Fans (Surface-Mounted Fans)

Continuously operated fans shall be rated at 1.0 sone or less. This 1.0 sone requirement applies to continuous dwelling unit ventilation fans and to continuous local exhaust ventilation fans.

B. Intermittent or Demand Controlled Fans (Surface-Mounted Fans)

Intermittently operated dwelling unit ventilation fans shall be rated at a maximum of 1.0 sone. Demand-controlled local exhaust fans shall be rated at a maximum of 3.0 sonas, unless the maximum rated airflow is greater than 400 CFM.

ASHRAE Standard 62.2 extends the requirement for quiet fans to include range hoods and bath exhaust fans, not just dwelling unit ventilation system fans. Dwelling unit ventilation fans or systems that operate continuously must be rated 1.0 sone or less, but demand-controlled local exhaust fans, including demand-controlled bathroom fans, must be 3.0 sonas or less. Range hood exhaust fans must also be rated at 3.0 sonas or less at the minimum required speed of 100 CFM.

4.6.9.3 Airflow Measurements and Airflow Ratings

From ASHRAE 62.2.

4.3 Airflow Measurement. The airflow required by this section is the quantity of outdoor ventilation air supplied and/or indoor air exhausted by the mechanical ventilation system as installed and shall be measured according to the ventilation equipment manufacturer's instructions, or by using a flow hood, flow grid, or other airflow measuring device at the mechanical ventilation fan's inlet terminals/grilles, outlet terminals/grilles, or in the connected ventilation ducts. Ventilation airflow of systems with multiple operating modes shall be tested in all modes designed to meet this section.

5.4 Airflow Measurement. The airflow required by this section is the quantity of indoor air exhausted by the ventilation system as installed and shall be measured according to the ventilation equipment manufacturer's instructions, or by using a flow hood, flow grid, or other airflow measuring device at the mechanical ventilation fan's inlet terminals, outlet terminals, or in the connected ventilation ducts.

Exception: The airflow rating, according to Section 7.1, at a pressure of 0.25 in. wc (62.5 Pa) may be used, provided the duct sizing meets the prescriptive requirements of Table 5.3 or manufacturer's design criteria.

All dwelling unit ventilation systems must demonstrate compliance by direct measurement of airflow using a flow hood, flow grid, or other approved measuring device. HERS verification of dwelling unit ventilation airflow is required for newly constructed buildings and existing buildings with additions greater than 1,000 square feet or an increase in the number of dwelling units.

There are two ways to demonstrate compliance with airflow requirements for local exhaust ventilation:

1. Test the ventilation system using an airflow measuring device after completion of the installation to confirm that the delivered ventilation airflow meets the requirement.
2. Conformance to a prescriptive requirement that the fan has a certified airflow rating that meets or exceeds the required ventilation airflow, and ventilation ducts meet either the fan manufacturer’s published duct design specifications or the prescriptive duct design requirements given in Table 4-16 (Table 5.3 of ASHRAE 62.2).

When using the prescriptive duct sizing table or manufacturer's design criteria for compliance, the certified airflow rating of the fan must be based on tested performance at the 0.25 inches water column (w.c.) static pressure. The airflow rating of a fan is available from the Home Ventilating Institute (HVI) Certified Products Directory at the HVI website (www.hvi.org).

If the manufacturer's duct system design specifications are used for compliance, the enforcement agency may require that the manufacturer's published system design documentation be provided for use for inspection of the installation(s).

The prescriptive duct design criteria given in Table 4-15 provide maximum exhaust duct lengths based on duct type and diameter. The higher the airflow, the larger in diameter or shorter in length the duct must be. Smooth duct can be used to manage longer duct runs. Interpolation and extrapolation of Table 4-15 are not allowed. For airflow rates not listed, use the next higher value. The table is not applicable for systems with airflow greater than 125 CFM at 62 Pa (0.25 inches water column) static pressure.

Table 4-15: Prescriptive Duct Sizing for Single-Fan Exhaust Systems

(ASHRAE 62.2, Table 5.3)

Duct Type	Flex Duct								Smooth Duct							
Fan Airflow CFM @ 0.25 in. (L/s @ 62.5 Pa)	50	80	100	125	150	200	250	300	50	80	100	125	150	200	250	300
	(25)	(40)	(50)	(65)	(75)	(100)	(125)	(150)	(25)	(40)	(50)	(65)	(75)	(100)	(125)	(150)
Diameter ^a , in.	Maximum Length ^{b,c,d} , ft (m)															
3 (75)	x	x	x	x	x	x	x	x	5 (2)	x	x	x	x	x	x	x
4 (100)	56	4	x	x	x	x	x	x	114	31	10	x	x	x	x	x
	(17)	(1)							(35)	(9)	(3)					
5 (125)	NL	81	42	16	2	x	x	x	NL	152	91	51	28	4	x	x
		(25)	(9)	(5)	(0.6)					(46)	(28)	(16)	(9)	(1)		
6 (150)	NL	NL	158	91	55	18	1	x	NL	NL	NL	168	112	53	25	9
			(48)	(28)	(17)	(5)	(0.3)					(51)	(34)	(16)	(8)	(3)
					161	78	40	19						148	88	54

7 (175)	NL	NL	NL	NL	(49)	(24)	(12)	(6)	NL	NL	NL	NL	NL	(45)	(27)	(16)
8 (200) and above	NL	NL	NL	NL	NL	189	111	69	NL	NL	NL	NL	NL	NL	198	133
						(58)	(34)	(21)							(60)	(41)

- a. For noncircular ducts, calculate the diameter as four times the cross-sectional area divided by the perimeter.
- b. This table assumes no elbows. Deduct 15 ft (5 m) of allowable duct length for each elbow.
- c. NL = no limit on duct length of this size.
- d. X = not allowed; any length of duct of this size with assumed turns and fitting will exceed the rated pressure drop.

Example 4-33 – Prescriptive Duct Sizing

Question:

I need to provide 75 CFM of continuous ventilation, which I plan to do using a central exhaust fan. I plan to connect the fan to a roof vent termination using flex duct. The duct will be about 8 feet long with no real elbows but some slight bends in the duct. What size duct do I need to use?

Answer:

From Table 4-15, using the 80 CFM, flex duct column, the maximum length with a 4-inch duct is 4 feet, so you cannot use 4 inches of duct. With a 5-inch duct, the maximum length is 81 feet, so that will clearly be adequate. Even if the bend in the duct is treated as an elbow, the allowable length only drops to 66 feet, more than adequate for the 8 feet required.

Example 4-34

Question:

For the situation in Example 4-30, again providing 75 CFM, what size duct would I need if smooth metal duct were used? In this case, the total length would increase to about 10 feet, and there would be two elbows.

Answer:

Using the 80 CFM, smooth duct column of Table 4-15, the maximum length of 4 inches duct is 31 feet. Subtracting 15 feet for each of the two elbows leaves 5 feet, which is not long enough. With a 5-inch duct, the maximum length is 152 feet. Subtracting 15 feet for each of the two elbows leaves 122 feet, so that will clearly be adequate.

Example 4-35

Question:

I will need a 100 CFM range hood. I have two possible duct routings. One is 15 feet long and will require three elbows. The other is 35 feet long but requires only one elbow. What size flex duct do I need to use?

Answer:

First, take the two routings and add in the correction for the elbows. Elbow corrections can be either added to the desired length or subtracted from the allowable length. In this case, we know the desired length, so we'll add the elbows. We get 15 feet plus 3 times 15 feet for a total of 60 feet, or 35 feet plus 15 feet equals 50 feet.

Looking at Table 4-15, in the 100 CFM, flex duct column, the maximum length with 5 inches duct is 42 feet, which is less than the adjusted length for either routing. With a 6-inch duct, the maximum length is 158 feet, longer than either adjusted length. A 6-inch duct would need to be used for either routing.

Note: The building code may not allow flex duct to be used for the range hood, in which case a smooth duct would be required. For a smooth duct, 5 inches would be acceptable.

4.6.9.4 Exhaust Ducts

From ASHRAE 62.2, Section 7.3, Exhaust Ducts.

7.3.1 Multiple Exhaust Fans Using One Duct. Exhaust fans in separate dwelling units shall not share a common exhaust duct. If more than one of the exhaust fans in a single dwelling unit shares a common exhaust duct, each fan shall be equipped with a backdraft damper to prevent the recirculation of exhaust air from one room to another through the exhaust ducting system.

7.3.2 Single Exhaust Fan Ducted to Multiple Inlets. Where exhaust inlets are commonly ducted across multiple dwelling units, one or more exhaust fans located downstream of the exhaust inlets shall be designed and intended to run continuously, or a system of one or more backdraft dampers shall be installed to isolate each dwelling unit from the common duct when the fan is not running.

ASHRAE Standard 62.2 contains restrictions on situations where multiple exhausts are connected through a combined duct system. These restrictions are intended to prevent air from moving between spaces through the exhaust ducts.

The first restriction is that if more than one exhaust fan in a dwelling shares a common duct, then each fan must be equipped with a backdraft damper so that air exhausted from one bathroom or unit is not allowed to go into another space. Exhaust fans in multiple dwelling units may not share a common duct.

The other restriction applies to remote fans serving more than one dwelling unit. Sometimes a single remote fan or HRV/ERV will exhaust air from several dwelling units in a multifamily building. This section requires that either the shared exhaust fan operate continuously or each unit be equipped with a backdraft damper so that air cannot flow from unit to unit when the fan is off.

In multifamily buildings, fire codes may impose additional restrictions.

4.6.9.5 Supply Ducts

From ASHRAE 62.2, Section 7.4, Supply Ducts.

Where supply outlets are commonly ducted across multiple dwelling units, one or more supply fans located upstream of all the supply outlets shall be designed and intended to run continuously, or a system of one or more backdraft dampers shall be installed to isolate each dwelling unit from the common duct when the fan is not running.

Supply outlets to more than one dwelling unit may be served by a single fan upstream of all the supply outlets if the fan is designed to run continuously or if each supply outlet is equipped with a backdraft damper to prevent cross-contamination when the fan is not running.

4.7 Alternative Systems

4.7.1 Hydronic Heating Systems

Hydronic heating is the use of hot water to distribute heat. Hydronic heating is discussed in this compliance manual as an “alternative system” because it is much less common in California than in other parts of the United States.

A hydronic heating system consists of a heat source, which may be a boiler, water heater, or heat pump, and a distribution system. There are three main types of hydronic distribution systems, and they may be used individually or in combination: baseboard convectors or radiators, air handlers, and radiant panel systems. Radiant panel surfaces can include floors, walls, and/or ceilings. Air handlers and radiant panels may be used for heating and cooling. Hot water air handlers may also be equipped with DX coils for cooling. The three distribution options are illustrated in Figure 4-32. Ducting is used only with air handlers.

4.7.1.1 Mandatory Requirements

For hydronic heating systems without ducts, the mandatory measures cover pipe insulation, tank insulation, and boiler efficiency. For fan coils with ducted air distribution, the mandatory air distribution measures also apply. For combined hydronic systems, as described below, mandatory water heating requirements also apply to the water heating portion of the system.

A. Pipe and Tank Insulation

§150.0(j) Insulation for Piping, and Tanks

§120.3 Requirements for Pipe Insulation

The typical residential hydronic heating system operating between 105° and 140° F must have at least 1 inch (25 mm) of insulation on pipes less than 1 inch in diameter and 1.5 inch (38 mm) of insulation on pipes 1 inch or more in diameter. Systems operating between 141° and 200° F must have at least 1.5 inches of

insulation on pipes less than 1.5 inches in diameter. For other temperatures and pipe insulation characteristics, see Table 4-5.

There are a few exceptions where insulation is not required:

1. Sections of pipes where they penetrate framing members
2. Pipes that provide the heat exchange surface for radiant heating and/or cooling
3. Piping in the attic that is covered by at least 4 inches (100 mm) of blown insulation on top
4. Piping installed within walls if all the requirements for Insulation Installation Quality are met (see Chapter 3 Building Envelope Requirements).

If the system includes an unfired hot water storage tank, then the tank must be either wrapped with R-12 insulation or insulated internally to at least R-16.

Piping used to deliver chilled water to panels or air handlers should be continuously insulated with closed-cell foam to prevent condensation damage.

Figure 4-33: Hydronic Heating System Components

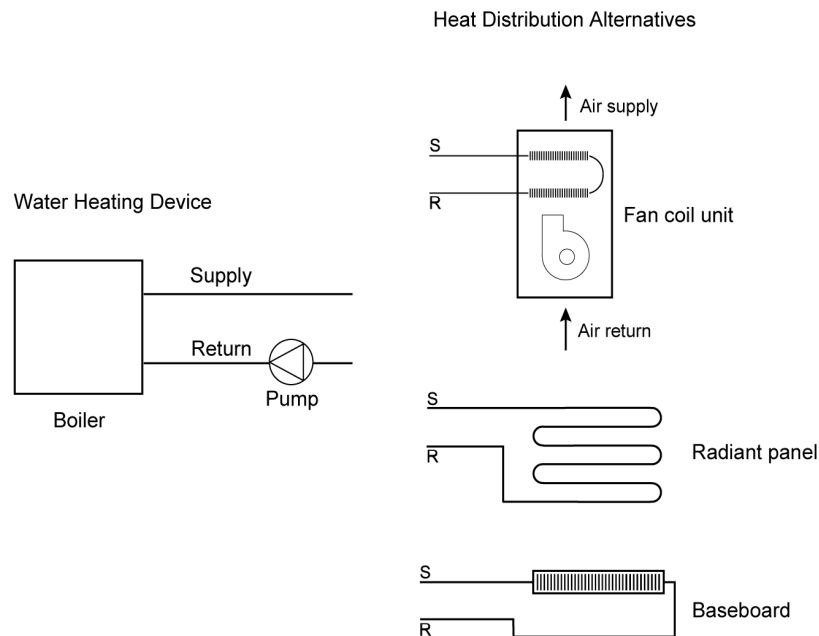

Source: Richard Heath & Associates/Pacific Gas and Electric Company

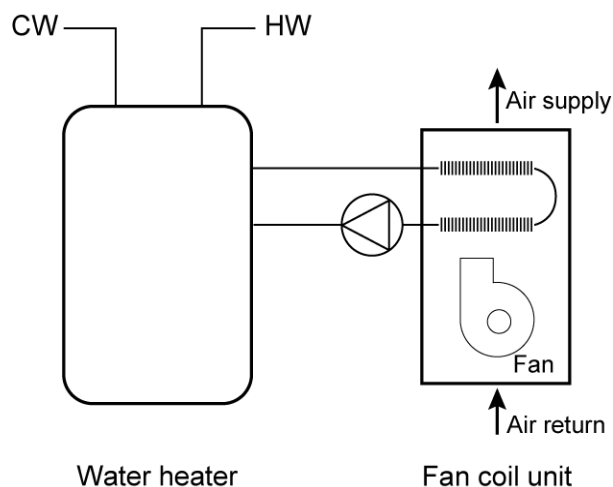
Figure 4-34: Combined Hydronic System With Water Heater as Heat Source

Source: Richard Heath & Associates/Pacific Gas and Electric Company

For pipes in hydronic heating systems that operate at pressure greater than 15 psi, the requirements of §120.3 apply. These are the same requirements that apply to nonresidential piping systems.

B. Equipment Efficiency

Gas or oil boilers used for residential space heating (typically less than 300,000 Btu/hr capacity) must be rated with an AFUE of 80 percent or greater. (See *Appliance Efficiency Regulations, Title 20* for minimum efficiencies of other heating equipment.) A gas or oil water heater may also be used as a dedicated source for space heating. Other hot water sources, including heat pumps or electric resistance water heaters, are not allowed for use in dedicated space-heating systems. Therefore, some water heaters may be used for space heating only if used as part of a combined hydronic system, as described below. In that case, the mandatory water heater requirements apply.

There are no minimum efficiency requirements for heat pumps that produce hot or chilled water, but compliance calculations must use ratings listed in the Energy Commission's Title 20 appliance database under the category "Central Heat Pumps" and Appliance Type "Heat Pump Water Heating Packages."

<https://cacertappliances.energy.ca.gov/Pages/ApplianceSearch.aspx>

Thermostat requirements also apply to hydronic systems, as described in Section 4.5.1.

4.7.1.2 Prescriptive Requirements

There are no specific prescriptive requirements that apply to hydronic systems. However, if the system has a fan coil with ducted air distribution, the relevant prescriptive requirements apply, including duct insulation and duct sealing.

4.7.1.3 Performance Compliance Options

Credit for choosing a hydronic heating system is possible using the performance compliance method. The standard design is assumed to have a furnace and ducted air distribution system. Therefore, hydronic systems without ducts can take credit for avoiding duct leakage penalties. In addition, minimizing the amount of pipe outside conditioned space will provide some savings. Hydronic heating and cooling compliance calculations are described in the *Residential ACM Manual*.

If the proposed hydronic system includes ducted air distribution, then the associated compliance options described earlier in this chapter may apply, such as improved airflow (if there is air conditioning) and supply duct location.

A “combined hydronic” system is another compliance option that is possible when using the performance method. *Combined hydronic heating* refers to the use of a single water heating device as the heat source for space and domestic hot water heating.

Combined hydronic systems may use either a boiler (as in the figure below) or a water heater as a heat source. The boiler heats domestic water by circulating hot water through a heat exchanger in an indirect-fired water heater. The water heater provides domestic hot water as usual.

Figure 4-35: Combined Hydronic System With Boiler and Indirect Fired Water Heater

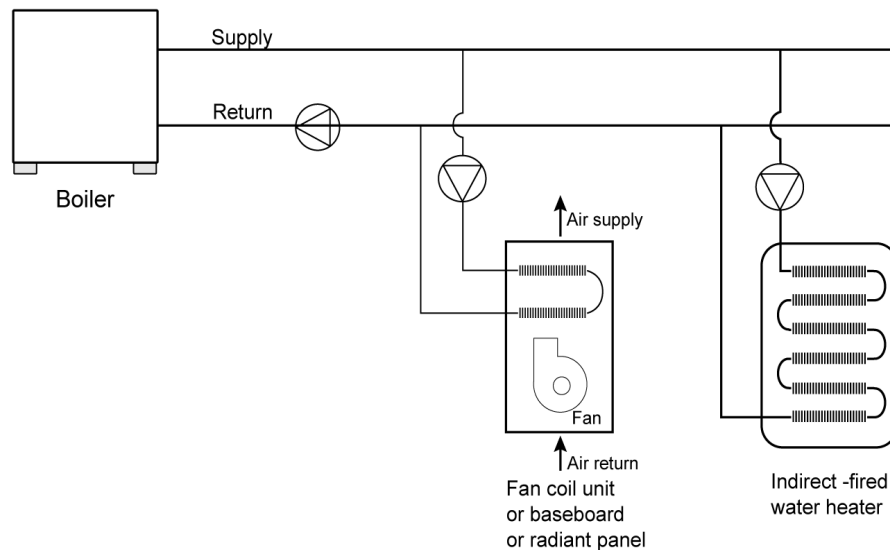

Source: Richard Heath & Associates/Pacific Gas and Electric Company

Space heating is accomplished by circulating water from the boiler or water heater through the space heating delivery system. Sometimes a heat exchanger is used to isolate potable water from the water circulated through the delivery system. Some water heaters have built-in heat exchangers for this purpose.

For compliance calculations, the water-heating function of a combined hydronic system is analyzed for water-heating performance as if the space-heating function were separate. For the space-heating function, an “effective” AFUE or HSPF rating

is calculated. These calculations are performed automatically by the compliance software.

4.7.2 Radiant Floor System

§110.8(g) and Table 118.0-A

Radiant floor systems, using either hydronic tubing or electric cable, must meet mandatory insulation measures. (See below.) Radiant floors may take one of several forms. Tubing or electric elements for radiant floor systems may be:

1. Embedded in a concrete floor slab.
2. Installed over the top of a wood subfloor and covered with a concrete topping.
3. Installed over the top of a wood subfloor in between wood furring strips.
4. Installed on the underside surface of a wood subfloor

In the latter two types of installations, aluminum fins are typically installed to spread the heat evenly over the floor surface and to reduce the temperature of the water as required. All hydronic systems use one or more pumps to circulate hot water. Pumps are controlled directly or indirectly by thermostats or by special outdoor reset controls. When concrete slabs are heated by radiant tubing or cables, one of the insulation methods listed below must be complied with to prevent excessive heat loss from the slab edge.

Table 4-16: Slab Insulation Requirements for Heated Slabs

Location of Insulation	Orientation of Insulation	Installation Criteria	Climate Zone	Insulation R-Value
Outside edge of heated slab, either inside or outside the foundation wall	Vertical	From the level of the top of the slab, down 16 inches or to the frost line, whichever is greater. Insulation may stop at the top of the footing where this is less than the required depth. For below-grade slabs, vertical insulation shall be extended from the top of the foundation wall to the bottom of the foundation (or the top of the footing) or frost line, whichever is greater.	1-15	5
			16	10
			1-15	5
Between heated slab and outside foundation wall	Vertical and Horizontal	Vertical insulation from the top of the slab at the inside edge of the outside wall down to the top of the horizontal insulation. Horizontal insulation from the outside edge of the vertical insulation extending 4 feet toward the center of the slab in a direction normal to the outside of the building in the plan view.	16	10 vertical and 7 horizontal

Source: 2019 Energy Standards Table 110.8-A

The required insulation value for each of these insulating methods is shown in Table 4-16.

Slab edge insulation applied to basement or retaining walls (with heated slab below grade) must be installed so that insulation starts at or above ground level and extends down to the bottom of the foundation or to the frost line, whichever is greater.

When using the performance compliance method with slab-on-grade construction, the standard design includes slab edge insulation as described above using the F-factors in Reference Joint Appendix JA4, Table 4.4.8.

When tubing or heating cables are set into a lightweight concrete topping slab laid over a raised floor, the edges of the radiant panel must not extend beyond the inside surface of insulated walls, and underside insulation must meet the mandatory minimum R-value for wood floor assemblies.

Figure 4-36: Heated Slab-On-Grade Floor Insulation Options

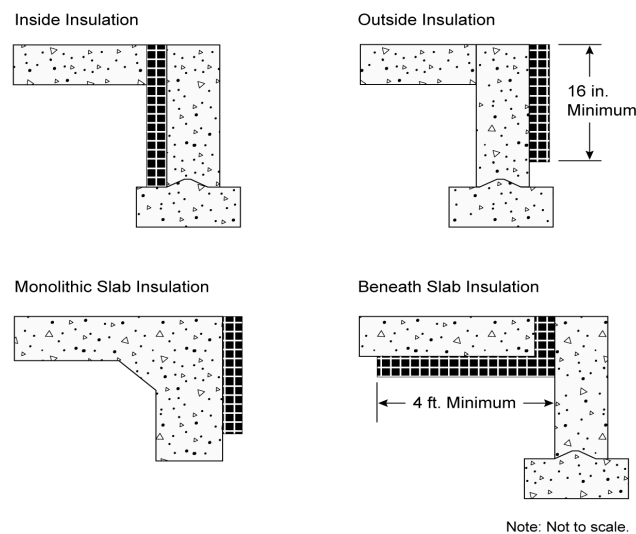

Source: California Energy Commission

Local conditions (such as a high water table) may require special insulation treatment to achieve satisfactory system performance and efficiency. To determine the need for additional insulation, follow the recommendations of the manufacturer of the hydronic tubing or heating element being installed. Where there is any danger of termite infestation, install termite barriers to prevent hidden access for insects from the ground to the building framing. Termite barrier flashing should be embedded into the concrete.

In addition to the insulation R-value requirements, §110.8(g)1 also sets mandatory measures related to moisture absorption properties of the insulation and protection of the insulation from physical damage or pest intrusion.

Example 4-36**Question:**

My client wants a dedicated hydronic-heating system (space heating only), but a few things are unclear: (1) What piping insulation is required? (2) Can I use any compliance approach? (3) Do I have to insulate the slab with slab edge insulation? (4) What special documentation must be submitted for this system type?

Answer:

(1) The supply lines not installed within a concrete radiant floor must be insulated in accordance with §150.0(j)2— Systems operating between 105° and 140° F must have at least 1 inch of insulation on pipes less than 1 inch in diameter, and 1.5 inches of insulation on pipes between 1 inch and less than 1.5 inches in diameter. Systems operating between 141° and 200° F must have at least 1.5 inches of insulation on pipes less than 1.5 inches in diameter.

(2) You can use any compliance approach, but the boiler must meet the mandatory efficiency 80 percent AFUE.

(3) The slab edge insulation shown in Table 4-16 is required only when the distribution system is a slab-on-grade radiant floor system (pipes in the slab). When this is the case, the insulation values shown are mandatory measures (no modeling or credit).

(4) No special documentation is required.

Example 4-37**Question:**

What are the slab edge insulation requirements for a hydronic-heating system with the hot water pipes in the slab?

Answer:

The requirements for slab edge insulation can be found in §110.8 and §150.0(l).

Material and installation specifications are as follows:

1. Insulation values as shown in Table 4-16
2. Protected from physical damage and ultraviolet light deterioration
3. Water absorption rate no greater than 0.3 percent (ASTM-C272)
4. Water vapor permeance no greater than 2.0 per inch (ASTM-E96-14).

4.7.3 Evaporative Cooling

Evaporative coolers cool a building by passing outdoor air through a wetted evaporative medium (direct evaporative cooler), by indirect cooling through a nonporous heat exchanger separating evaporatively cooled secondary air from outdoor air, or by a combination indirect-direct system that combines an indirect heat exchanger with a downstream direct evaporative process. Although direct coolers are most common, the more advanced indirect and indirect-direct systems offer generally lower supply air temperatures with less moisture introduced to the indoor space. For the Energy Standards, performance credit is allowed only for indirect and indirect-direct evaporative cooling systems. All coolers receiving credits within the *ACM Manual* must be listed in the Energy Commission's Title 20 Evaporative Cooler appliance database

(<https://cacertappliances.energy.ca.gov/Pages/ApplianceSearch.aspx>).

Evaporative coolers may be used with any compliance approach. In the prescriptive compliance approach, all evaporative coolers are treated as a minimum efficiency 13.0 SEER air conditioner.

In the performance approach, the compliance software uses an hourly model based on unit effectiveness, supply airflow, and power to determine the magnitude of the credit based on climate conditions and unit sizing relative to the loads. Typical cooling budget credits are 20-30 percent, depending upon these factors.

The evaporative cooling system must meet the following requirements to receive credit based on the hourly performance method described above. Direct coolers, as well as indirect and indirect-direct coolers not meeting these criteria, shall be modeled as a minimum efficiency (13.0 SEER) central air conditioner.

1. The equipment manufacturer shall certify to the Energy Commission that water use does not exceed 7.5 gallons per ton hour based on the Title 20 Appliance Efficiency Regulations testing criteria.

2. Equipment shall be permanently installed (no window or portable units).
3. Installation shall provide for automatic relief of supply air from the house with maximum air velocity through the relief dampers not exceeding 800 feet per minute (at the Title 20 rated airflow). Pressure relief dampers and ductwork shall be distributed to provide adequate airflow through all habitable rooms. For installations with an attic, ceiling dampers shall be installed to relieve air into the attic and then outside through attic vents. For installations without an attic, sidewall relief dampers are acceptable.
4. To minimize water consumption, bleed systems are not allowed.
5. A water quality management system (either “pump down” or conductivity sensor) is required. “Pump down” systems can either be integral to the evaporative cooler or they can be accessories that operate on a timed interval. The time interval between pumps shall be set to a minimum of 6 hours of cooler operation. Longer intervals are encouraged if local water quality allows. Automatic systems that use conductivity sensors provide the best water efficiency compared to a timed pump down system. These sensors monitor the water quality and don’t unnecessarily drain the water based on elapsed time.
6. Automatic thermostats are required. Manual on/off controls are not allowed.
7. If the evaporative cooler duct system is shared with a heating and/or cooling system, the installed duct system shall employ backdraft dampers at the evaporative cooler supply.
8. The installing contractor must provide a winter closure device that substantially blocks outdoor air from entering the indoor space.
9. The size of the water inlet connection at the evaporative cooler shall not exceed 3/8 inch.
10. Unless prohibited by local code, the sump overflow line shall not be directly connected to a drain and shall terminate in a location that is normally visible to the building occupants.

Example 4-38**Question:**

How are applications with vapor compression cooling systems and evaporative cooling systems handled?

Answer:

In situations where evaporative cooling system(s) and vapor compression system(s) are installed in a house, the size of the evaporative cooler will dictate the magnitude of the credit. The performance approach will ensure that an evaporative cooler sized to meet most of the cooling loads will generate a higher credit than one sized to meet a fraction of the design cooling load.

Example 4-40

Question:

How do you model multiple evaporative coolers on one house?

Answer:

In situations with multiple evaporative coolers, effectiveness inputs should be averaged, and airflow and power inputs should be totaled. Performance characteristics of each piece of equipment should be listed on the compliance forms.

4.7.4 Ground-Source Heat Pumps

Table 4-17 – Standards for Ground Water-Source and Ground-Source Heat Pumps Manufactured on or After October 29, 2003

Appliance	Rating Condition	Minimum Standard
Ground water-source heat pumps (cooling)	59° F entering water temperature	16.2 EER
Ground water-source heat pumps (heating)	50° F entering water temperature	3.6 COP
Ground-source heat pumps (cooling)	77° F entering brine temperature	13.4 EER
Ground-source heat pumps (heating)	32° F entering brine temperature	3.1 COP

Section 1605.3 Table C-7 of the *2015 California Appliance Efficiency Regulations*

A geothermal or ground-source heat pump uses the earth as a source of energy for heating and as a heat sink for energy when cooling. Some systems pump water from an aquifer in the ground and return the water to the ground after exchanging heat with the water. A few systems use refrigerant directly in a loop of piping buried in the ground. Those heat pumps that either use a water loop or pump water from an aquifer have efficiency test methods that are accepted by the Energy Commission.

The mandatory minimum efficiencies for ground water-source heat pumps shown in Table 4-17 are certified to the Energy Commission by the manufacturer and are expressed in terms of coefficient of performance (COP) for heating and EER for cooling.

Verify that the system will meet local code conditions before choosing this type of system to meet the Energy Standards.

4.7.5 Solar Space Heating

Solar space-heating systems are not recognized within either the prescriptive packages or the performance compliance method.

4.7.6 Wood Space Heating

The Energy Commission's exceptional method for wood heaters with any type of backup heating is available in areas where natural gas is not available. If the required eligibility criteria are met, a building with one or more wood heaters may be shown to comply with the Energy Standards using either the prescriptive or performance approaches as described below.

4.7.6.1 Prescriptive Approach

The building envelope conservation measures of the component package must be installed. The overall heating system efficiency (wood stove plus backup system) must comply with the prescriptive requirements.

4.7.6.2 Performance Approach

A computer compliance method may be used by modeling wood heat, which simulates an 80 percent AFUE central furnace with ducts that meet prescriptive requirements.

4.7.6.3 Wood Heater Qualification Criteria

The Energy Standards establish exceptional method guidelines for the use of wood heaters. If all the criteria for the wood heat exceptional method are not met, a backup heating system must be included in the compliance calculations as the primary heat source.

The building department having jurisdiction must determine that natural gas is not available.

Note: Liquefied petroleum gas, or propane, is not considered natural gas.

The following eligibility criteria apply:

1. The local or regional air quality authority must determine that its authorization of this exceptional method is consistent with state and regional ambient air quality requirements according to Sections 39000 to 42708 of the California Health and Safety Code.
2. The wood heater must be installed in a manner that meets the requirements of all applicable health and safety codes, including, but not limited to, applicable requirements for maintaining indoor air quality.
3. The wood heater must meet the EPA definition of a wood heater as defined in Title 40, Part 60, Subpart AAA of the Code of Federal Regulations (40CFR60 Subpart AAA) (See below.)
4. The performance of the wood heater must be certified by a nationally recognized agency and approved by the building department having jurisdiction to meet the performance standards of the EPA.
5. The rated output of the wood heater must be at least 60 percent of the design heating load, using calculation methods and design conditions as specified in §150(h).
6. At the discretion of the local enforcement agency, a backup heating system may be required and designed to provide all or part of the design heating load, using calculation methods and design conditions as specified in §150(h).
7. The wood heater must be located such that transfer of heat from the wood heater is effectively distributed throughout the entire residential dwelling unit, or

it must be used in conjunction with a mechanical means of providing heat distribution throughout the dwelling.

8. Habitable rooms separated from the wood heater by one free opening of less than 15 ft² or two or more doors must be provided with a positive heat distribution system, such as a thermostatically controlled fan system. Habitable rooms do not include closets or bathrooms.
9. Wood heaters on a lower level are considered to heat rooms on the next level up, provided they are not separated by two or more doors.
10. The wood heater must be installed according to manufacturer and local enforcement agency specifications and must include instructions for homeowners that describe safe operation.
11. The local enforcement agency may require documentation that demonstrates that a particular wood heater meets all these requirements.

Federal regulation 40CFR60 Subpart AAA includes minimum criteria for wood heaters established by the U.S. EPA. These criteria define a wood heater as an enclosed, wood-burning appliance capable of and intended for space heating or domestic water heating that meets all the following criteria:

1. An air-to-fuel ratio averaging less than 35 to 1
2. A firebox volume less than 20 ft³.
3. A minimum burn rate less than 5 kilogram/hour (11.0 lbs/hr)
4. A maximum weight of less than 800 kilograms (1,760 lbs)
5. The federal rules explicitly exclude furnaces, boilers, cook stoves, and open masonry fireplaces constructed on site, but include wood-heater inserts.

Example 4-41

Question:

Are pellet stoves treated the same as wood stoves for compliance with the Energy Standards?

Answer:

Yes.

Example 4-42

Question: If a wood stove is installed in a wall, does it have to meet the fireplace requirements of §150(e)?

Answer:

No. A wood stove that meets EPA certification requirements does not have to meet any requirements applicable to fireplaces.

4.7.7 Gas Appliances

§110.5 Pilot Lights

Pilot lights are prohibited in fan-type central furnaces, pool heaters, spa heaters, and natural gas indoor and outdoor fireplaces.

Household cooking appliances are also prohibited from having a pilot light unless there is no electrical supply voltage connection and each pilot consumes less than 150 Btu/hr.

For requirements related to installation of fireplaces, decorative gas appliances, and gas logs, see Chapter 3 of this manual.

4.7.8 Evaporatively Cooled Condensers

Evaporatively cooled condenser air conditioners are a type of air-conditioning system that can provide significant space-cooling savings, especially in hot, dry climates. The equipment minimal efficiencies are determined according to federal test procedures. The efficiencies of these air conditioners are reported in terms of energy efficiency rating (EER).

If credit is taken for a high EER, field verification by a HERS Rater is required. Other HERS-verified measures are also required, including duct sealing, airflow, fan efficacy, and refrigerant charge or fault indicator display.

Besides the HERS verification, there are additional special requirements for evaporatively cooled condensing air conditioners. These include that the manufacturer provide certification that water use is limited to no more than 0.15 gallon per minute per ton of capacity and that the supply line be no larger than ¼-inch in diameter. For a listing of all the requirements for evaporatively cooled condensing air conditioners, see the CF2R compliance form.

4.7.9 Nonducted Systems

Several manufacturers offer equipment that does not use air distribution ducts to heat or cool spaces. These systems use either refrigerant or water that is heated and/or cooled to condition the space. These systems may provide advanced controls and multispeed compressors for optimizing performance through a wide range of conditioning loads without losing efficiency.

These systems are required to be modeled as minimally efficient systems because a compliance option that specifies appropriate modeling rules and installation criteria has not been developed or approved. All applicable HERS verifications are required to be conducted for these systems, if possible.

4.7.10 Ventilation Cooling

Ventilation cooling is differentiated from the mechanical ventilation provided to maintain adequate indoor air quality, in that the primary focus is to bring in higher volumes of cool outdoor air (if available) to cool the dwelling unit to reduce the use of

conventional vapor compression air conditioning. Ventilation cooling systems generally operate during summer evenings and nights when cooler outdoor air is available. The cooler outdoor air ventilation reduces indoor air temperatures during the evening and nighttime hours, and in the process cools the building interior thermal mass, which may offset or eliminate the next-day cooling loads of the dwelling. Ventilation cooling systems may cool the dwelling to temperatures that are below the normal air conditioner set point, which may improve the effectiveness of the next-day cooling load offset. The effectiveness of ventilation cooling depends upon the climate conditions, thermal envelope, and how much indoor temperature variation the occupant will tolerate.

Figure 4-37 compares cooling energy use over a day for two identical houses, one with and one without ventilation cooling, and illustrates how ventilation cooling can offset most of the air-conditioning energy by use of a relatively small amount of off-peak ventilation fan operation.

Figure 4-37: Diurnal Temperature Variation and Ventilation Cooling

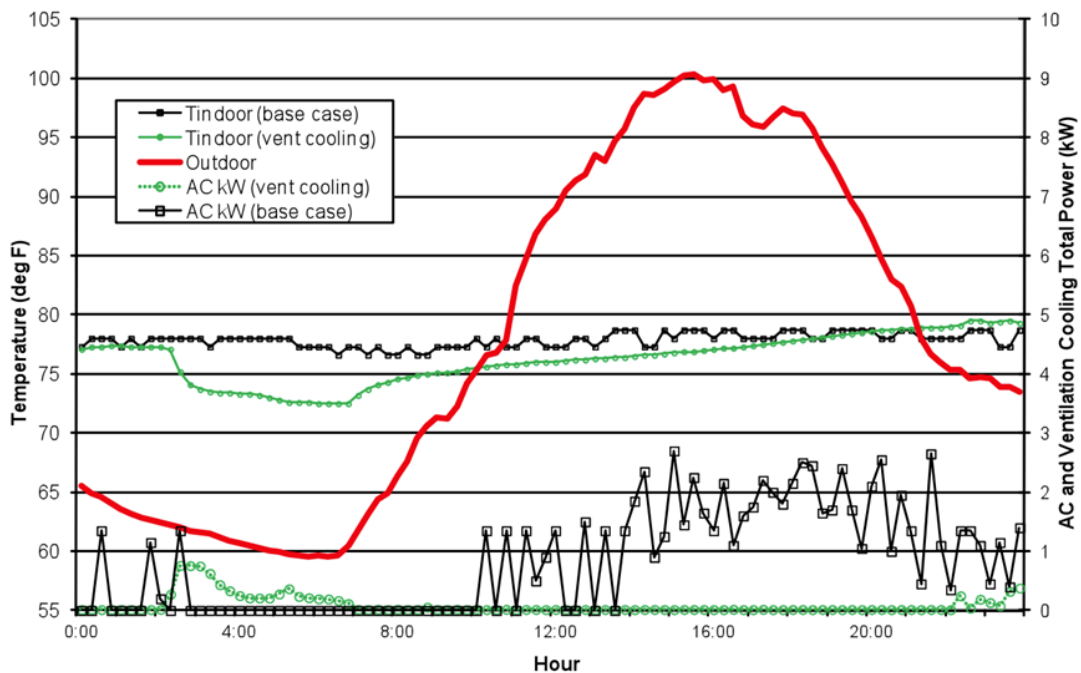

Source: California Energy Commission

4.7.10.1 Whole-House Fans

The simplest form of ventilation cooling is a whole-house fan (WHF), which draws cooler outdoor air through open windows, exhausts the warmer air into the attic, and then expels the air outside through attic vents.

Traditional whole-house fans have a simple barometric damper (Figure 4-38) and either a belt-driven or direct-drive motor driving a prop fan. Figure 4-39 shows the damper open with the fan immediately above.

Figure 4-40 shows a similar product that moves less air but provides an insulated damper with a better leakage seal between the attic and conditioned space. These units are generally designed to fit between standard rafter spacing, simplifying retrofit installations.

Finally, Figure 4-41 shows a remote whole-house fan design that removes the fan farther from indoor space, reducing noise during operation.

WHFs cool a dwelling space most effectively when all windows throughout the house are opened only enough to produce a fairly uniform airflow into all rooms throughout the dwelling while not restricting the WHF total airflow. This results in the greatest interaction of the cool air with the interior mass throughout the dwelling, providing the greatest amount of stored cooling. Running the fan all night long increases the effectiveness of the next-day cooling offset by more fully “charging” the thermal mass. Noise can be reduced through either use of a variable-speed control or installation of a multispeed fan, allowing low-speed nighttime operation.

Security concerns may arise if windows are left open at night, but most window products can be secured if they are only partially open, thus providing the minimum open area for air to enter the room but preventing unauthorized entry from outside the dwelling.

Homeowners who have sensitivities to particulate matter in the outdoor air should consider that dust and allergens present in the outdoor air will easily enter the dwelling through the open windows during operation of a WHF.

The WHFs used to comply with the Energy Standards must be listed in the Energy Commission’s Appliance Database which can be accessed at <https://cacertappliances.energy.ca.gov/Pages/ApplianceSearch.aspx>.

Figure 4-38: Whole-House Fan With Barometric Damper



Source: California Energy Commission

Figure 4-39: Open Barometric Damper With Fan Above



Source: California Energy Commission

Figure 4-40: Insulated Whole-House Fan With Damper Actuation



Source: California Energy Commission

Figure 4-41: Ducted Remote Whole-House Fan



Source: California Energy Commission

4.7.10.2 Central Fan Ventilation Cooling Systems

Another type of ventilation cooling system, the central fan ventilation cooling system (CFVCS) uses an automatically controlled outside air damper and the HVAC system fan or other fan to draw outside air through a large outdoor air vent and distributes the cool outdoor air through the HVAC system ductwork. Warm indoor air is then expelled into the attic through the same damper.

Primary advantages of this system include filtration of outside air, elimination of the need to open windows (improved security), and automatic sensing of the moment when the outdoor air temperature falls below the indoor temperature. A disadvantage of central fan systems is that they typically move less air and consume more energy per CFM as compared to a whole-house fan because of the more restrictive duct systems.

Figure 4-42 shows the airflow path through a CFVCS when the system is not operating to provide ventilation cooling (return air mode). In this mode, the system performs the same as a conventional central space-conditioning system, drawing the return air from the conditioned space, through the heating/cooling coils, then back to the conditioned space.

Figure 4-42: Central Fan Ventilation Cooling System (Return Air Mode)

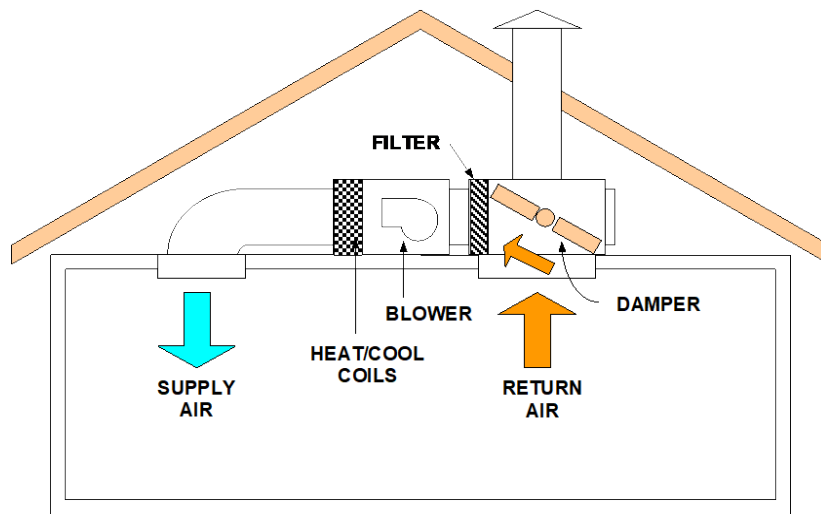

Source: California Energy Commission

Figure 4-43 shows the airflow paths when the system is operating to provide ventilation cooling (outdoor air mode). In this mode, the damper changes position and draws outdoor air through the outdoor air intake vent, through the air handler, and then to the conditioned space. During outdoor air mode, the cooling/heating coils are not operated, and the damper allows indoor air to pass into the attic, then back to outdoors through the attic vents.

Figure 4-43: Central Fan Ventilation Cooling System (Outdoor Air Mode)

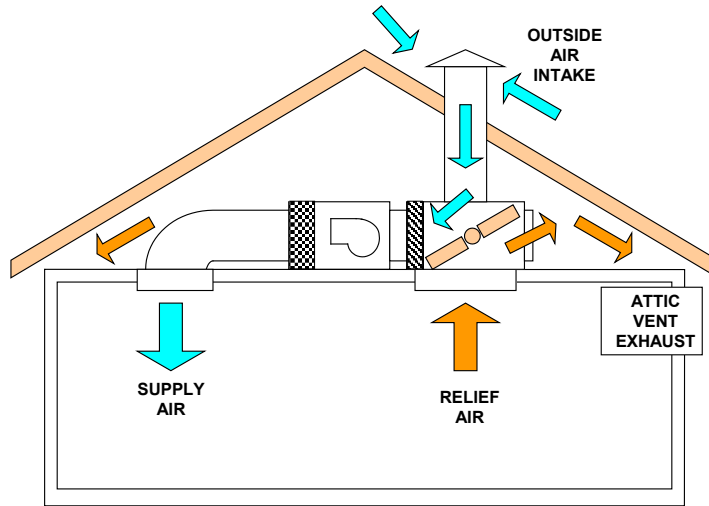

Source: California Energy Commission

Figure 4-44: Sample Rooftop Air Intake

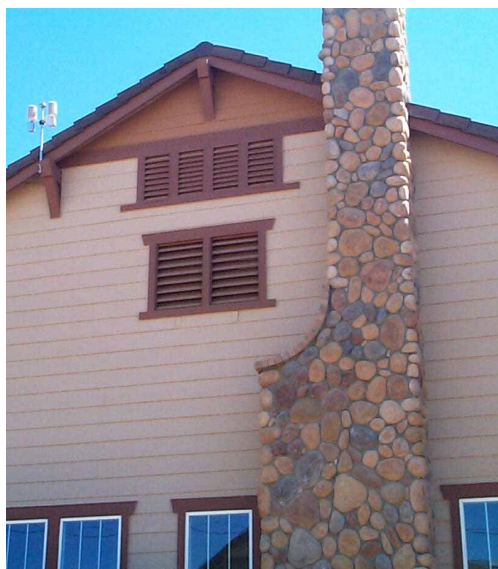

Source: California Energy Commission

Figure 4-45: Sample Gable End Air Intake (Lower Set of Vents)

Source: California Energy Commission

CFVCSs may use a variable-speed motor with a fan-speed control that responds to outdoor temperature conditions and indoor comfort settings, which may improve energy savings compared to fixed-speed CFVCSs.

4.7.10.3 Prescriptive Requirements

Component packages specify a WHF as a prescriptive requirement for single-family newly constructed buildings in Climate Zones 8 through 14. The WHF, or CFVCS, must meet the eligibility criteria specified below to meet the prescriptive requirement.

Additions of 1,000 ft² or less are exempt from the whole-house fan prescriptive requirements.

4.7.10.3.1 Eligibility Criteria for Whole-House Fans

§150.1(c)12

1. Where atmospherically vented combustion appliances or solid-fuel burning appliances are located inside the pressure boundary, the operation of the whole-house fan must be considered in determining the adequacy of providing combustion air and prevention of back-drafting, which may cause toxic products of combustion to enter conditioned space of the the dwelling.
2. WHFs used to comply with the Energy Standards must be listed in the Energy Commission Appliance Database.
3. To meet the prescriptive requirement, the installed WHF(s) must have a listed airflow of at least 1.5 CFM/ft² of conditioned floor area. The house must have a minimum attic net free vent area to outdoors of one square foot per 750 CFM of installed whole-house fan(s) rated airflow. See Table 4-18

and Table 4-19 for net free ventilation area requirements based on the square footage of the house.

4. Homeowners who have WHFs installed must be provided with a one-page “How to operate your whole house fan” informational sheet.

A. Eligibility Criteria for Central Fan Ventilation Cooling Systems

CFVCS may be approved for use for compliance credits as “fixed-speed” systems or as “variable speed” systems. The Energy Commission must review submittals from manufacturer applicants and determine whether the system meets the qualifying criteria:

When applying for approval for either fixed speed or variable speed systems, the manufacturer must provide documentation to demonstrate the system meets the criteria listed in paragraphs 1, 2, and 3 below

1. CFVCS must meet the applicable duct leakage requirements with the system operating in return air mode (Figure 4-42).
2. CFVCS must be HERS verified for airflow (CFM) and fan efficacy (w/CFM), demonstrating an efficacy of no more than 0.45 watts/CFM for furnaces, 0.58 W/CFM for heat pumps, and 0.62W/CFM for small duct, high velocity systems.
3. In addition to sensing temperature at the thermostat, the CFVCS must have an outdoor temperature sensor to initiate and terminate ventilation cooling operation and a means to detect damper failure.

When applying for approval as a variable speed system, the manufacturer must also provide the documentation described in paragraphs 4, 5, and 6 below.

4. The installed fan motor is a variable-speed motor.
5. The motor is controlled in ventilation cooling mode to vary in a continuous range between full air flow (100 percent) and a minimum airflow of no more than 25 percent of full airflow.
6. The manufacturer must provide written documentation that describes how its control strategy is implemented, how the ventilation cooling fan speed is controlled, and how ventilation cooling rates are determined. The ventilation cooling rate calculation must occur within a 24-hour interval or less to ensure that the system responds in a timely manner to changes in weather patterns.

Table 4-18 shows example conversions for the calculated net free vent area (NFVA) for a range of whole-house fan airflow levels. Instead of using the table, one can calculate the NFVA by dividing the listed CFM by 750.

Table 4-18: Sample NFVA Calculation

CEC Listed Airflow (CFM)	Minimum Attic NFVA (ft2)
2000	2.7
3000	4
4000	5.3
5000	6.7
6000	8
7000	9.3

Source: California Energy Commission

Since attic vents present some level of airflow restriction, use the appropriate screen and louver reduction factor from Table 4–19.

Table 4-19: Attic Vent Airflow Reduction Factors

Vent Type	Reduction Factor
¼" screen (hardware cloth)	0.90
¼" screen with metal louvers	0.75
¼" screen with wood louvers	0.25
Insect screen (mesh under ¼")	0.50
Insect screen with metal louvers	0.50
¼" screen with wood louvers	0.25

Source: California Energy Commission

Example 4-43

Required vent area = Minimum Attic NFVA (Table 4-18) ÷ Reduction Factor

A 3,000 CFM fan is selected from the Energy Commission Appliance Database. The builder plans to use vents with ¼" screen with metal louvers.

Answer

The minimum required vent area is = $4.0 \div 0.90 = 4.4 \text{ ft}^2$

Example 4-44 – Ventilation Cooling

Question:

I am building a 2,350 ft² house in Climate Zone 8. Do I need to install a whole-house fan or central fan ventilation system?

Answer:

Yes, if you are complying prescriptively.

No, if you are complying using the performance method and no whole-house fan was modeled.

Whole-house fans are a prescriptive requirement in Climate Zones 8-14, meaning that they are not mandatory, although they define the prescriptive compliance level. If you decide to install a whole-house fan to meet the prescriptive requirement, you should select a fan from the Energy Commission Appliance Database. The prescriptive requirement specifies a minimum airflow of 1.5 CFM/ft² (3,525 CFM for the proposed house) and 1 ft² of attic net free ventilation area per 750 CFM of airflow (4.7 ft² for a 3,525 CFM fan).

Example 4-45

Question:

Why do I need to provide attic ventilation area for a whole-house fan?

Answer:

Whole-house fans move a lot of air from inside the dwelling unit, all of which is exhausted to the attic. Without sufficient attic relief to the outdoors, the fan will move less air.

Example 4-46

Question:

What are the advantages and disadvantages of whole-house fans relative to central fan ventilation cooling systems?

Answer:

Whole-house fans are relatively inexpensive; both in first cost and operating cost, and are highly effective if used properly in the right climate. They move much more air than central fan systems, which must deliver air through the duct system. Whole-house fans may be noisy, require user operation to open windows, turn on and off, bring in dust and allergens from outside, and potentially reduce home security if windows are left open throughout the night. Central fan systems are more expensive and generally move less air, but provide totally automated operation, independent of whether the occupant is home. Windows can remain shut, and all outdoor air is filtered. Some central fan systems may also be configured to provide ventilation that complies with the whole-dwelling indoor air quality requirements in Section 150.0(o). Review product literature to determine if available products meet the Energy Commission's fresh air ventilation requirements.

Example 4-47

Question:

A two-story home with 2,500 sf of conditioned space and an attic is located in Climate Zone 10. Is a whole-house fan required? Does this affect the number of vents in the attic?

Answer:

Yes, if complying prescriptively. Section 150.1(c)12 requires whole-house fans (WHF) in single-family houses that are in Climate Zones 8-14. These are climate zones that have summer cooling needs but where the home can be efficiently cooled on cool summer evenings by the use of a whole-house fan.

Section 150.1(c)12 also requires that these fans be sized so they provide at least 1.5 cubic feet per minute (CFM) of flow for each square foot of conditioned space in the house. The fans used must be listed in the Energy Commission's Appliance Database (<http://appliances.energy.ca.gov/QuickSearch.aspx>) and the rated CFM listed on the CF2R-MCH-02 form. In addition, the attic must have at least 1 sf of attic vent free area for each 750 CFM of whole-house fan-rated flow.

Thus, for this house with 2,500 sf of conditioned floor area, the minimum total flow rate of whole-house fans installed in the house must be at least:

Min WHF flow rate = Conditioned Floor Area x 1.5 CFM/sf = 2,500 sf x 1.5 CFM/sf = 3,750 CFM.

In this case, the builder has selected two 2,000 CFM whole-house fans. The minimum amount of vent net-free area in the attic is calculated as follows:

Net Free Area = Total WHF CFM / (750 CFM/sf NFA) = (2,000 + 2,000) / 750 = 5.3 sf

4.8 Refrigerant Charge

4.8.1 Refrigerant Charge Verification

This section summarizes the procedures for verifying refrigerant charge for air-conditioning systems as described in Section RA3.2 of the Reference Residential Appendix.

4.8.1.1 Overview

A split-system air conditioner undergoes the final assembly at installation. The installation must be verified to ensure proper performance. Important factors that affect performance include the amount of refrigerant in the system (the charge) and the proper functioning of the metering device. Air conditioner energy efficiency suffers if the refrigerant charge is either too low or too high and if the metering device (TXV or EXV) is not functioning properly. In addition to a loss of efficiency and capacity, errors in these areas can lead to premature compressor failure.

To help avoid these problems, the prescriptive standards require that systems be correctly installed. The prescriptive standards also require that they be field-verified in Climate Zones 2 and 8 through 15. Refrigerant charge verification is also required in any climate zone when chosen as a compliance feature using the performance approach.

The requirement to verify the refrigerant charge after installation does not apply to new packaged systems, where the installer certifies the package system came

factory-charged and did not alter the system in any way that would affect the refrigerant level; however, airflow and other requirements must still be verified. The prescriptive standards regarding verification of refrigerant charge do apply to altered package systems in Climate Zones 2 and 8 through 15.

Verification of proper refrigerant charge must occur after the HVAC contractor has installed and charged the system in accordance with the manufacturer's specifications. The procedure requires properly calibrated digital refrigerant gauges, thermocouples, and digital thermometers. When multiple systems in the same home require testing, test each system.

In a typical home cooling system, there are two important performance criteria that are relatively easy to verify that there is neither too much nor too little refrigerant in the system. In systems with a fixed-orifice device in the evaporator coil, the number to check is called the *superheat*. In a system with a variable-metering device, the number to check is called the *subcooling*.

Superheat refers to the number of degrees the refrigerant is raised after it evaporates into a gas. This occurs inside the evaporator coil (or *indoor coil*). The correct superheat for a system will vary depending on certain operating conditions. The target superheat for a system must be obtained from a table provided in the RA3.2 protocols or the manufacturer's superheat table. There is an allowed range of several degrees between the measured superheat and the target superheat for a system to pass.

Subcooling refers to the number of degrees the refrigerant is lowered after it condenses into a liquid. This occurs inside the condenser coil (or *outdoor coil*). The manufacturer specifies the correct subcooling for a system. It may vary depending on operating conditions. Like superheat, there is an allowed range of several degrees between the measured subcooling and the target subcooling for a system to pass.

The temperature at which a refrigerant condenses or evaporates is called the *saturation temperature*. Above the saturation temperature, a refrigerant is always a gas. Below the saturation temperature, a refrigerant is always a liquid.

Saturation is when a refrigerant exists as both a liquid and a gas. It always occurs at the same temperature, depending on what the pressure of the refrigerant happens to be. At higher pressures, the saturation temperature goes up and vice versa. This convenient property is what makes refrigeration work.

The saturation temperature can be determined by simply measuring the pressure of a refrigerant and referring to a table, known as a *pressure-temperature (PT) table*, for that specific refrigerant. Saturation temperatures are well-documented for all common refrigerants.

Because variable refrigerant metering devices are prone to failure and even more so to improper installation, it is important that the operation of these devices be checked. A metering device maintains a relatively constant superheat over a wide range of operating conditions; therefore, checking the superheat, in addition to the other tests performed, will indicate if the metering device is operating correctly.

Unfortunately, checking superheat and subcooling can be done only under certain indoor and outdoor conditions. This verification procedure, called the Standard Charge Verification Method, is very weather-dependent.

There is another way to verify proper refrigerant charge that is not weather-dependent, and that is by weighing the refrigerant. Called the Weigh-in Charge Verification Method, this approach can be performed only by the installer. It can be verified by the HERS Rater either by simultaneous observation or by using the standard method when conditions permit.

4.8.1.2 Minimum System Airflow Verification for Refrigerant Charge Verification

To have a valid charge test, the system airflow must be verified to be at least 300 CFM/ton for altered systems and 350 CFM/ton for new systems. The procedures for measuring total system airflow are found in RA3.3. They include plenum pressure matching using a fan flow meter, a flow grid, a powered flow hood, and the traditional (nonpowered) flow hood. The airflow verification procedures for refrigerant charge verification no longer include the temperature split method.

If an altered system does not meet the minimum airflow requirements, remedial steps are required to increase system airflow. More airflow is generally better for systems with air conditioning. Not only does this allow proper refrigerant charge to be verified, but it improves the overall performance of the system. When able to be performed on a system, regardless of the refrigerant charge verification procedure, minimum system airflow must always be verified.

In some alterations, improving airflow may be cost-prohibitive, and there is a process for documenting this (RA3.3.3.1.5). When this option is used, verification by sample groups is not allowed. Minimum airflow is critical to proper air-conditioner operation. Reducing airflow reduces cooling capacity and efficiency. Many systems in California have oversized equipment and undersized ducts. In newly installed duct systems, the minimum airflow requirement is higher because the opportunity exists to design and install a better system. In altered systems, the installer may be required to modify the ducts system to meet the minimum airflow. The minimums of 300 and 350 CFM/ton are lower than the desired airflow for most systems, which is usually 400 CFM/ton and higher.

4.8.1.3 Standard Charge Verification Procedure (RA3.2.2)

The first step is to turn on the air-conditioning system and let it run for at least 15 minutes to stabilize temperatures and pressures. While the system is stabilizing, the HERS Rater or the installer may attach the instruments needed to take the measurements.

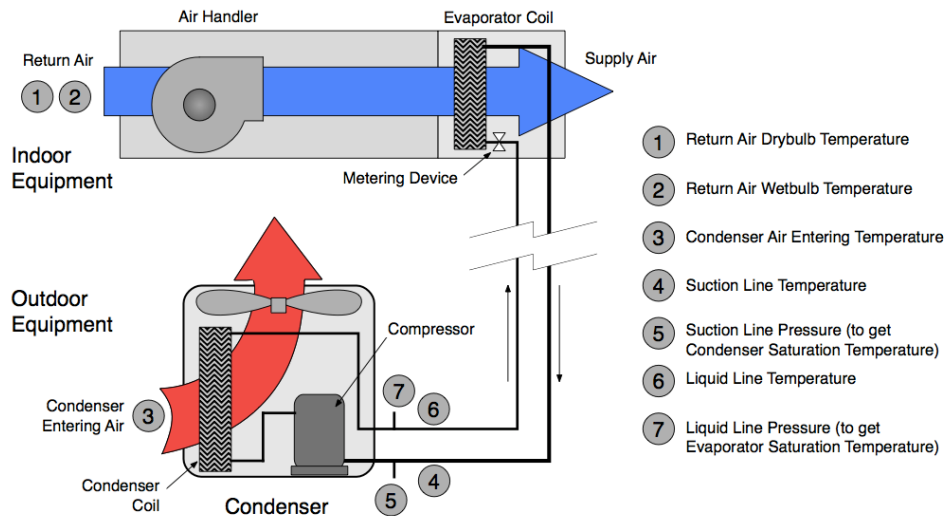
Figure 4-45: Measurements for Refrigerant Charge and Airflow Tests

Source: California Energy Commission

The following measurements shall be taken by the technician or HERS Rater, when applicable.

1. The return air wet bulb and dry bulb temperatures are measured in the return plenum before the blower at the location labeled "Title 24 – Return Plenum Measurement Access Hole." This hole must be provided by the installer, not the rater (See Points 1 and 2 in Figure 4-45). See Figure RA 3.2-1 for more information on the placement of the measurement access hole (MAH).
2. Moreover, the outdoor air dry bulb temperature is measured at the point where the air enters the outdoor condensing coil. (See Point 3 in Figure 4-45). It is important that this outdoor temperature sensor be shaded from direct sun during the verification procedure.

In addition to the air temperature measurements, four refrigerant properties need to be measured. Two of these measurements are taken near the suction line service valve before the line enters the outdoor unit and are used to check the superheat.

1. The first measurement is the temperature of the refrigerant in the suction line, which is taken by a clamp-on thermocouple or other suitable device insulated from the outdoor air. (See Point 4 in Figure 4-45.)
2. The second measurement determines the saturation temperature of the refrigerant in the evaporator coil. (See Point 5 in Figure 4-45.) The saturation temperature can be determined from the low-side (suction line) pressure and a saturation temperature table for the applicable refrigerant.

To check the subcooling, two more refrigerant properties are required and may be measured near the liquid line service valve at the point where the line exits the outdoor unit.:

1. The liquid refrigerant temperature in the liquid line is measured by a clamp-on thermocouple insulated from the outdoor air. (See Point 6 in Figure 4-45.)
2. The condenser saturation temperature can be determined from the liquid line pressure and a saturation temperature table for the applicable refrigerant. (See Point 7 in Figure 4-45.)

Determination of the condenser saturation temperature and the liquid line temperature is used only for the subcooling verification method on systems with TXV or EXV metering devices.

4.8.1.4 Superheat Charge Verification Method (RA3.2.2.6.1)

The *Superheat Charge Verification Method* is used on units with a fixed refrigerant metering device (not a TXV or EXV).

Airflow verification must be confirmed before starting the Superheat Verification Method.

Table 4-20: Structure of Target Superheat

		Return Air Wet-Bulb Temperature (°F) (T Return, wb)									
		50	51	52	53	54	55	--	--	75	76
Condenser Air Dry-Bulb Temperature (° F) (T condenser, db)	55	Target Superheat = Suction Line Temperature minus Evaporator Saturation Temperature See Reference Residential Appendix Table RA3.2-2									
	56										
	57										
	--										
	--										
	93										
	94										
	95										

Source: California Energy Commission

The *Superheat Verification Method* compares the actual (measured) superheat temperature to a target value from a table. The actual superheat temperature is the measured suction line temperature ($T_{\text{Suction, db}}$) minus the evaporator saturation temperature ($T_{\text{Evaporator, Saturation}}$). The target superheat value is read from a table (Table RA3.2-2 of the Reference Residential Appendix or the manufacturer’s superheat table).

For illustration, the structure of Table RA3.2-2 is shown above as Table 4-20.

Only an EPA-certified technician may add or remove refrigerant. Under no circumstances may HERS Raters add or remove refrigerant on systems that they are verifying.

4.8.1.5 Subcooling Verification Method (RA3.2.2.6.2)

The *Subcooling Verification Method* is used on units with a variable refrigerant metering device (a TXV or EXV).

Airflow verification must be confirmed before starting the Subcooling Verification Method.

The Subcooling Verification Method compares the actual subcooling temperature to the target value supplied by the manufacturer. The actual subcooling is the condenser saturation temperature ($T_{\text{Condenser, Saturation}}$) minus the liquid line temperature (T_{Liquid}).

4.8.1.6 Weigh-In Charging Procedure (RA3.2.3)

The weigh-in charging procedure charges the system by determining the appropriate weight of refrigerant based on the size of the equipment and refrigerant lines rather than by measuring steady-state performance of the system. Systems using the weigh-in procedure to meet the refrigerant charge verification requirement may not use group sampling procedures for HERS verification compliance..

The weigh-in procedure does not relieve the installer of the responsibility to comply with the required minimum system airflow.

There are two installer options for completing the weigh-in procedure. One involves adjusting the amount of refrigerant supplied by the manufacturer in a new system, as specified by the manufacturer (weigh-in charge adjustment). The other involves evacuating the entire system and recharging it with the correct total amount of refrigerant, by weight (weigh-in total charge).

The weigh-in charge adjustment procedure may be used only when a new factory-charged outdoor unit is being installed and the manufacturer provides adjustment specifications based on evaporator coil size and refrigerant line size and length.

The weigh-in total charge may be used for any weigh-in procedure but still requires manufacturer's adjustment specifications. Only the installer/technician may perform any kind of weigh-in procedure.

4.8.1.7 Equipment Limitations

The Energy Standards specifically require verification of refrigerant charge only for air-cooled air conditioners and air-source heat pumps. All other types of systems are not expressly exempt from the refrigerant charge requirements. Certain portions of the requirements may still apply, such as the minimum system airflow requirement. The installer would have to verify with the manufacturer and confirm with the Energy Commission. The installer must adhere strictly to the manufacturer's specifications.

Variable refrigerant flow systems and systems such as some mini-split systems that cannot be verified using the standard charge verification procedure in RA3.2.2 must demonstrate compliance using the weigh-in method. Verification by the HERS Rater can be accomplished only by simultaneous observation of the installer's weigh-in as

specified by RA3.2.3.2, and only if use of HERS Rater observation procedure is specified by the Standards.

4.8.1.8 HERS Verification Procedures

When required by the certificate of compliance, HERS Raters must perform field verification and diagnostic testing of the refrigerant charge, including verification of minimum system airflow and verification of installation of the measurement access hole.

The verification procedures are essentially identical for the rater and the installer except that the tolerances for passing the superheat and subcooling tests are less stringent for the rater's test. This is to allow for some variations in measurements due to instrumentation or test conditions (for example, weather).

The following conditions prohibit verification using sample groups:

1. When the weigh-in method is used
2. When the minimum airflow cannot be met despite reasonable remediation attempts. (See RA3.3.3.1.5).

As always, to be eligible for sampling, the installer must first verify and pass the system. If sampling is not being used, the rater will perform the verification only after the installer has charged the system according to manufacturer's specifications.

4.8.1.9 Winter Setup Procedures

Reference Appendix RA1 provides for the approval of special case refrigerant charge verification procedures. These protocols may be used only if the manufacturer has approved use of the procedure for their equipment.

One such procedure is found in RA1.2 Winter Setup for the standard charge verification procedure (winter charge setup). It provides for a modification to the standard charge procedure when temperature conditions do not allow use of the RA3.2.2 standard charge verification procedure.

The winter charge setup allows both installers and HERS Raters to verify the charge when outdoor temperatures are below the manufacturer's allowed temperature, or the outdoor temperature is less than 55°F. The Weigh-in Charging Procedure specified in Section RA3.2.3 may also be used when the outdoor temperatures are below the manufacturer's allowed temperature or below 55°F, but may be used only by the installer.

The winter charge setup procedure allows the system to operate in the same range of pressure differences between the low-side pressure and the high-side pressure as occurs during warm outdoor temperatures, by restricting the airflow at the condenser fan outlet. The winter charge setup is used only for units equipped with variable metering devices, which include thermostatic expansion valves (TXV) and electronic expansion valves (EXV) for which the manufacturer specifies subcooling as the means for determining the proper charge for the unit, including units equipped with microchannel heat exchangers. Once this pressure differential is achieved, the

variable metering device calculations are conducted in the same way as the variable metering device procedures described in Reference Residential Appendix RA 3.2.2.6.2. All other applicable requirements of Section RA3.2.2 remain the same and must be completed when using the winter charge setup.

Though not specifically mentioned in the FID protocols in Residential Appendix RA3.4.2, the RA 1.2 winter setup method may be used if applicable. Thus for FID verification, the winter setup method may be used in place of the subcooling method.

4.8.1.10 Using Weigh-In Charging Procedure at Low Outdoor Temperatures

When a new HVAC system is installed, the HVAC installer must check the refrigerant charge, and a HERS Rater must verify the correct charge; however, an exception to §150.1(c)7A provides for an alternative third-party HERS verification if the weigh-in method is used when the outdoor temperature is less than 55 degrees F.

Typically, when the weigh-in method is used by the installing contractor, a HERS Rater must perform a charge verification in accordance with the RA3.2. standard charge procedure. However, because the RA3.2.2 procedures cannot be used when the outdoor temperatures are less than 55 degrees, the Energy Standards provide the installer with two choices:

1. Use the RA3.2.3.2 HERS Rater Observation of Weigh-In Charging Procedure to demonstrate compliance, and install an occupant-controlled smart thermostat (OCST).
2. Wait for warmer temperatures and perform the standard charge verification procedure. In this case, the installer must agree to return to correct refrigerant charge if a HERS Rater determines later, when the outside temperature is 55 degrees F or above, that correction is necessary as described in Residential Appendix RA 2.4.4. The installer must also provide written notice to the homeowner that the charge has not yet been verified. An example homeowner's notification is shown in Figure 4-46.

Figure 4-46: Example of Notification to Homeowners of Delayed Charged Verification

Note to Homeowner: We're not done yet!

Congratulations on your new Air-Conditioning system! Your new system is much more efficient than older systems, and it has been installed to industry guidelines, ensuring many years of comfort and efficient service.

One thing you need to know, however, is that the installation process is not complete! Because your unit was installed when the outside air temperature was too low to fine tune the air conditioner, the unit must be serviced and verified when the weather is warmer.

This requires your cooperation. You need to allow access to the unit for your Installer and/or HERS Rater (verifier) to verify that the refrigerant charge and airflow are set correctly. Your project is not considered finished until this verification takes place. If it is not done, **your unit may cost more to operate, may not heat and cool as effectively, and may not last as long.**

You will be contacted within the next few months to schedule this service. If you do not hear something after a few months of warmer weather, please contact your Installer. Enjoy your new system!

Source: California Energy Commission

4.9 Compliance and Enforcement

This section describes compliance documentation and field verification requirements related to heating and cooling systems.

4.9.1 Design-Phase Documentation

The initial compliance documentation consists of the certificate of compliance (CF1R). It lists the features that the house needs for compliance with the prescriptive or performance requirements.

For the prescriptive compliance approach, the required features are based on the Prescriptive Component Package, shown in Table 150.1-A or 150.1-B.

For the performance compliance approach, the required features are based on a set of features that the designer has documented to result in a level of efficiency at least as good as Prescriptive Component Package A. The calculations for documenting this are done using the approved performance compliance software. The calculation approach is described in the *Alternative Calculation Method (ACM) Reference Manual*.

The performance compliance approach provides maximum design flexibility. It also allows compliance credit for special additional features to be quantified.

The CF1R has a section where special modeling features are listed. These are features for which special compliance credit was taken using the performance approach. They require additional visual verification by the enforcement agency to ensure proper installation. Some require field verification and diagnostic testing by a HERS Rater. These will be listed in a separate section.

The following are heating and cooling system features that will be listed in this section if they exist in the proposed design:

Special Features Not Requiring HERS Rater verification:

1. Ducts in a basement
2. Ducts in a crawlspace
3. Ducts in an attic with a radiant barrier
4. Hydronic heating and system design details
5. Gas-fired absorption cooling
6. Zonal control
7. Ductless wall heaters

Special features requiring HERS Rater verification:

1. Duct sealing

2. Verified duct design – for reduced duct surface area and ducts in conditioned space
3. Low-leakage ducts in conditioned space
4. Low-leakage air handlers
5. Verification of return duct design
6. Verification of air filter device design
7. Verification of bypass duct prohibition
8. Refrigerant charge verification
9. Installation of a fault indicator display (FID)
10. Verified system airflow
11. Air handler fan watt draw
12. High energy efficiency ratio (EER)
13. Verified seasonal energy efficiency ratio (SEER)
14. Heating seasonal performance factor (HSPF)
15. Heat pump - rated heating capacity
16. Continuous dwelling unit mechanical ventilation airflow for IAQ
17. Intermittent dwelling unit mechanical ventilation airflow for IAQ
18. Kitchen range hood verification for IAQ
19. Building or dwelling unit enclosure air leakage
20. High-quality insulation installation (QII)
21. Whole-house fan airflow and fan efficacy
22. Central fan ventilation cooling system verification

Information summarizing measures requiring field verification and diagnostic testing is presented in Table RA2-1 of the Reference Residential Appendix RA2. The field verification and diagnostic testing protocols that must be followed to qualify for compliance credit are described in RA3 of the Reference Residential Appendix.

Registration of the CF1R with an approved HERS Provider is required. The building owner or the person responsible for the design must submit the CF1R to the HERS Provider Data Registry for retention according to the procedures described in Section 10-103, and Section RA2 of the Reference Residential Appendix.

Registration ensures that the project follows the appropriate verification process, provides tracking, and provides electronic access to the documentation.

4.9.2 Construction-Phase Documentation

During construction, the general contractor or specialty subcontractors must complete all applicable certificate of installation (CF2R) documents for the building design special features specified on the certificate of compliance (CF1R).

Like the CF1R, registration of the CF2R is required. The licensed contractor responsible for the installation must submit the CF2R information that applies to the installation to a HERS Provider Data registry using procedures described in Section 10-103, and Section RA2 of the Reference Residential Appendix. CF2R documents corresponding to the list of special features requiring HERS Rater verification in Section 4.9.1 above are required.

4.9.3 Field Verification and/or Diagnostic Testing

For buildings for which the certificate of compliance (CF1R) requires HERS field verification for compliance with the Energy Standards, a HERS Rater must visit the site to perform field verification and diagnostic testing to complete the applicable heating and cooling system certificates of field verification and diagnostic testing (CF3R). CF3R documents corresponding to the list of special features requiring HERS Rater verification in Section 4.9.1 above are required.

Field verification for nonmandatory features is necessary only when performance credit is taken for the measure. Some field verification is for mandatory measures and will occur in all homes, unless they are exempt from the measure.

Like the CF1R and CF2R, registration of the CF3R is required. The HERS Rater must submit the field verification and diagnostic testing information to the HERS Provider Data Registry as described in Chapter 2. For additional details describing HERS verification and the registration procedure, refer to RA2 of the Reference Residential Appendix.

Table of Contents

5	Water Heating Requirements	1
5.1	Overview	1
5.1.1	What's New for 2019	1
5.1.2	At a Glance	2
5.1.3	Water Heating Energy	2
5.2	Residential Water Heating Equipment	3
5.2.1	Instantaneous Water Heaters	4
5.2.2	Storage Water Heater	4
5.2.3	Water Heater Maintenance	7
5.2.4	Drain Water Heat Recovery Devices	8
5.3	Mandatory Requirements for Water Heating	9
5.3.1	Equipment Certification	9
5.3.2	Equipment Efficiency	10
5.3.3	Isolation Valves	13
5.3.4	High-Efficiency Water Heater Ready	13
5.3.5	Mandatory Requirements for Hot Water Distribution Systems	16
5.4	Prescriptive Requirements for Water Heating	23
5.4.1	Single Dwelling Units	23
5.4.2	Multiple Dwelling Units: Multifamily, Motel/Hotels, and High-Rise Residential ..	27
5.5	Performance Approach Compliance for Water Heating	31
5.5.1	Energy Budget Calculation	31
5.5.2	Systems Serving a Single Dwelling Unit	31
5.5.3	Systems Serving Multiple Dwelling Units	32
5.5.4	Treatment of Water Heater Efficiency	33
5.5.5	Compliance Issues	33
5.6	Distribution Systems	33
5.6.1	Types of Water Heating Distribution Systems	33
5.6.2	Systems Serving a Single Dwelling Unit	34
5.6.3	Systems Serving Multiple Dwelling Units	42
5.7	Combined Hydronic System	44

- 5.7.1 Combined Hydronic..... 44
- 5.8 Showerheads..... 44
 - 5.8.1 Certification of Showerheads and Faucets..... 44
- 5.9 Solar Water Heating 44
 - 5.9.1 Solar or Recovered Energy in State Buildings 45
 - 5.9.2 Prescriptive Requirements for Solar Water Heating 46
 - 5.9.3 Performance Approach Compliance for Solar Water Heating 48
- 5.10 Swimming Pool and Spa Heating 48
 - 5.10.1 Swimming Pool and Spa Types 48
 - 5.10.2 Mandatory Requirements for Pools and Spas..... 48
- 5.11 Compliance and Enforcement..... 53
 - 5.11.1 Design Review 53
 - 5.11.2 Field Inspection 53
 - 5.11.3 HERS Field Verification and/or Diagnostic Testing 54
- 5.12 Glossary/Reference 54
 - 5.12.1 General Glossary/Reference for Water Heating..... 54
 - 5.12.2 General Glossary/Reference for Swimming Pool and Spa..... 55

5 Water Heating Requirements

5.1 Overview

Chapter 5 describes the compliance requirements for domestic water heating for newly constructed residential dwellings, including single-family, and low-rise (three or fewer habitable floors) multifamily buildings. This chapter also describes common water heater types, best practices for water heater maintenance, hot water distribution system designs, and examples of commonly asked questions regarding compliance with Energy Standards requirements. For general information about compliance and enforcement please see Chapter 2 of this compliance manual. For information about water heating requirements for additions and alterations, please see Chapter 9.

5.1.1 What's New for 2019

This section summarizes changes to the requirements for residential water heating for the *2019 Energy Standards*. Please see Sections 5.3 and 5.4 for detailed information on the mandatory and prescriptive water heating requirements in the *2019 Energy Standards*.

5.1.1.1 Mandatory Requirements

1. Requirement for temperature controls in public lavatories has been removed to align with plumbing code.
2. The high efficiency water heater ready requirement for electrical receptacle has been updated to require the receptacles to be dedicated and connected to a 120/240 volt 3 conductor, 10 American Wire Gauge (AWG) branch circuit. This change allows easier and cheaper installation of heat pump water heater as a replacement.

5.1.1.2 Prescriptive Requirements

Significant changes to the 2019 prescriptive requirements for single-family buildings and multifamily buildings with a dedicated water heater in each dwelling unit include the following:

1. Heat pump water heaters were added as a possible prescriptive path option.
2. Drain water heat recovery was added as a possible prescriptive path option.
3. Hot water pipe insulation was removed since it is now required under the California plumbing code. (A Home Energy Rating System [HERS] verified pipe insulation remains as a compliance option)
4. The maximum input rating for gas storage water heaters over 55 gallons was reduced to 75,000 British thermal unit per hour (Btu/Hr) to better align with U.S. Department of Energy (DOE) classification.

Significant changes to the 2019 prescriptive requirements for multifamily buildings with a central water heating system include the following:

1. Drain water heat recovery can be used to reduce the required solar savings fraction of the solar thermal system.

5.1.1.3 Performance Compliance Method

When the performance compliance method is used, the water heating energy budget now has an independent gas or electric baseline based on the proposed water heater type. For gas type water heaters, the energy budget is based on the performance of a gas instantaneous water heater. For electric water heaters, the energy budget is based on the performance of a heat pump water heater with compact hot water distribution and a drain water heat recovery device. Both gas and electric water heaters used in the baseline meet the minimum requirements in California's *Title 20 Appliance Efficiency Regulations* Section 1605.1(f) for federally regulated appliances. For more information, see section 5.5.

5.1.2 At a Glance

Table 5-1 provides an overview of the location of the water heating requirements in the *2019 Energy Standards* by construction and building type.

Table 5-1: Overview of Water Heating Requirements in the Energy Standards and this Chapter

Type	Mandatory Requirements		Prescriptive Requirements		Performance Requirements	
	Standards Section	Manual Section	Standards Section	Manual Section	Standards Section	Manual Section
Single-family home – Newly built	§110.3; §150.0(j) §150.0(n)	5.3	§150.1(c)8A i, ii, iii, iv, v	5.4.1	§150.1(b)	5.5
Single-family home – Addition	§110.3; §150.0(j) §150.0(n)	5.3, 9	§150.2(a)1D	5.4.1	§150.2(a)2	5.5
Single-family home – Alteration	§110.3; §150.0(j) §150.0(n)	5.3, 9	§150.2(b)1H	5.4.1	§150.2(b)2	5.5
Multi-family – Newly built individual dwelling units	§110.3; §150.0(j) §150.0(n)	5.3	§150.1(c)8B	5.4.2	§150.1(b)	5.5

5.1.3 Water Heating Energy

Total energy use associated with water heating consists of the end use, heater inefficiencies, standby loss, and distribution system inefficiencies. Figure 5-1 below

shows the energy flows that constitute water heating energy usage. Hot water draws at the end use points (for example, faucets, showers, and so forth) represent the useful energy consumed. In most cases, hot water that is actually used represents the largest fraction of water heating energy use, although in situations when there are very few hot water draws, standby losses from a standard gas storage water heater and the hot water distribution system can exceed the quantity of useful energy consumed at the end point. Energy impacts associated with the hot water distribution system vary widely based on the type of system, quality of insulation and installation, building and plumbing design, and hot water use patterns. Distribution losses in a typical single-family home may be as much as 30 percent of the total energy used for water heating. Distribution losses in single-family homes with compact hot water distribution systems may be lower than 10 percent of total water heating energy use. In a typical multifamily building, distribution losses can account for more than 30 percent of total water heating energy use. An important consideration for any water heating system is the recovery load (that is, end use plus distribution losses) of the water heating unit minus any contribution from auxiliary heat inputs, such as a solar thermal system.

Figure 5-1: Water Heating Energy Flow Representation

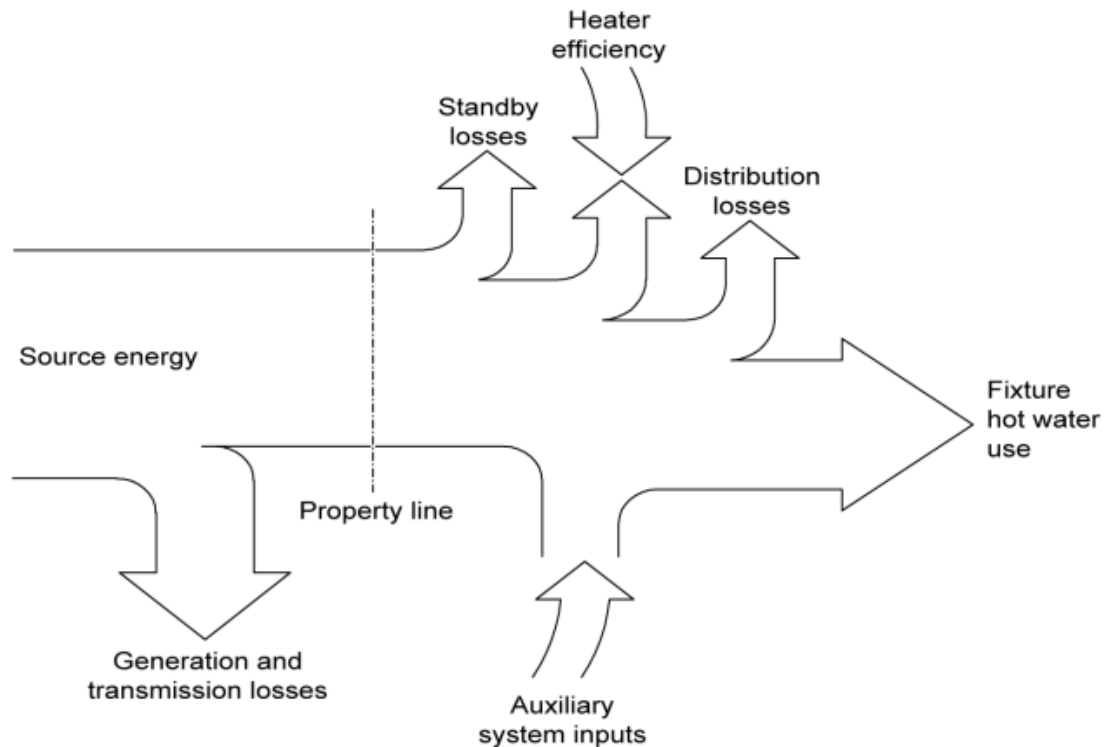

5.2 Residential Water Heating Equipment

There are several types of residential water heaters described below. The most common water heaters in single-family homes are consumer storage or instantaneous water heaters. For multifamily buildings, two options are commonly used: A central domestic hot water system with one or more commercial storage water heaters or one

or more boilers coupled with a storage tank to serve the entire building. Alternatively, water heaters are installed in each dwelling unit (similar to single-family).

To comply with the Energy Standards using either the prescriptive or performance approach, the water heater must meet the federal and/or the California Appliance Efficiency Regulations (Title 20).

5.2.1 Instantaneous Water Heaters

Instantaneous water heaters, commonly referred to as *tankless* or *on-demand*, heat water using natural gas, electricity, or propane. These units do not have a tank for storing heated water but instead use a sensor that detects the flow of water over the heat exchanger that initiates the heating element (typical volumes around 0.5 gallons). Instantaneous units are capable of delivering water at a controlled temperature of less than 180°F. The input rating for gas instantaneous water heaters ranges between 50,000 and 200,000 BTU per hour (at least 4,000 BTU per hour per gallon of stored water) with a storage capacity of less than 2 gallons.

Instantaneous water heaters require an electrical connection for controls and the combustion air blower, a direct or power venting system, and a larger gas line (typical input ratings of 140,000 to 200,000 BTU/hr).

Electric instantaneous water heaters are not generally designed for use with solar water heating systems or as heat sources for indirect-fired water heaters. They are also typically inappropriate for use with recirculation systems. Consult manufacturer's literature when considering these applications. Electric instantaneous water heaters are not allowed through the prescriptive approach to compliance but can be installed using the performance approach as long as the total energy budget is not exceeded.

To comply prescriptively with the *Energy Standards*, a user can choose to install a gas or propane instantaneous water heater that meets the minimum efficiency requirements of California's *Title 20 Appliance Efficiency Regulations* Section 1605.1(f) for federally regulated appliances.

5.2.2 Storage Water Heater

5.2.2.1 Consumer Storage Water Heaters

Storage water heaters use gas (natural gas or propane), electricity or oil to heat and store water at a thermostatically controlled temperature (less than 180°F) for delivery on demand. Federal appliance efficiency standards differentiate storage water heaters based on whether the rated storage volume is greater than 55 gallons or less than or equal to 55 gallons.

The U.S. Department of Energy (DOE) classifies consumer gas water heaters as having an input of 75,000 BTU per hour or less and has a storage capacity ranging between 20 and 100 gallons. A basic gas storage water heater is composed of a standing pilot ignition system, a burner, a combustion chamber, a flue baffle, a flue, an insulated water tank, a cold water inlet and hot water outlet, a sacrificial anode, a gas valve, a temperature and pressure relief valve, a thermostat, heat traps, and an outer case.

The DOE classifies consumer electric storage water heaters as having an input of 12 kilowatt (kW) or less and have a storage capacity ranging between 20 and 120 gallons. A basic electric storage consumer water heater differs from gas water heaters by using an electric resistance heating element. As noted in this chapter, electric storage water heaters are not allowed through the prescriptive approach to compliance but can be installed using the performance approach as long as the water heating energy budget is not exceeded.

Recently DOE added a new category of water heaters called *grid-enabled water heaters* and is defined as an electric resistance water heater that has a rated storage tank volume of more than 75 gallons and is manufactured on or after April 16, 2015. The water heater must have an activation lock at the point of manufacture and is intended for use only as part of an electric thermal storage or demand response program.

5.2.2.2 Heat Pump Water Heater (HPWH)

A heat pump water heater (HPWH) is an electric water heater that works like a refrigerator in reverse. It uses a compressor to transfer heat from the surrounding air to the water tank. It includes all necessary auxiliary equipment such as fans, storage tanks, pumps, or controls. Typically, HPWHs include backup electric resistance elements to ensure hot water delivery when the air temperature is too cold or the hot water demand is too high. Some models entering the market use larger compressors to avoid the need for resistance elements.

The performance of HPWHs depends heavily on air temperature because they rely on extracting heat from the air. Buildings in warm and cold climate zones, and different installation locations such as a garage or vented outdoor closet, all have an impact on performance and must be considered. HPWHs are most efficient in warmer climates, but even in cold climate zones such as Climate Zone 16, HPWHs still use only half as much electricity as conventional electric resistance water heaters. In addition to air temperature sensitivity, HPWH performance is affected by cold water inlet temperatures as introduction and mixing of inlet water during larger draws may trigger second stage electric resistance heating in the tank.

The Northwest Energy Efficiency Alliance (NEEA) Advanced Water Heater Specification was developed to address critical performance and comfort issues of HPWH in colder climates. Tiers are incorporated into this specification recognizing variations in product performance and configuration. An HPWH that meets the NEEA Advanced Water Heater Specification performs significantly better in real world conditions, and an HPWH that meets the NEEA Tier 3 or higher can be used to meet the prescriptive requirement for newly constructed buildings, addition, and alteration.

The list of qualified product list of NEEA HPWH can be found here:

<https://neea.org/img/documents/qualified-products-list.pdf>

5.2.2.3 Residential-Duty Commercial Water Heater

This appliance is essentially a commercial water heater that can be legally installed in a residential building. It is defined in the Federal Code of Regulations (10 CFR 431.102) as any gas-fired, electric, or oil storage or instantaneous commercial water heater that meets the following conditions:

1. Uses a single-phase external power supply for models that require electricity.
2. Is not designed to provide outlet hot water at temperatures greater than 180°F.
3. Is not excluded by the specified limitations regarding rated input and storage capacity as described in Table 5-2 below. In other words, a residential-duty commercial water heater must have rate input and rated storage volume **below** the value listed in Table 5-2.

Table 5-2: Capacity Limitations for Defining Commercial Water Heaters Without Residential Applications

<i>Water Heater Type</i>	<i>Indicator of Nonresidential Application</i>
Gas-Fired Storage	Rated input >105 kBtu/h; Rated storage volume >120 gallons.
Oil-Fired Storage	Rated input >140 kBtu/h; Rated storage volume >120 gallons.
Electric Instantaneous	Rated input >58.6 kW; Rated storage volume >2 gallons.

Source: U.S. Department of Energy (2014). “Energy Conservation Program for Consumer Products and Certain Commercial and Industrial Equipment: Test Procedures for Residential and Commercial Water Heaters; Final Rule.” <http://www.regulations.gov/#!documentDetail;D=EERE-2011-BT-TP-0042-0082>

Residential-duty commercial water heaters are rated in uniform energy factor (UEF) and are allowed through the prescriptive approach to compliance but can also be installed using the performance approach as long as the total energy budget is not exceeded.

5.2.2.4 Hot Water Supply Boiler

A *hot water supply boiler* is industrial water heating equipment with a heat input rate from 300 to 12,500 kBtu per hour and at least 4,000 BTU per hour per gallon of stored water. A hot water boiler should have either the temperature or pressure control necessary for heating potable water for purposes other than space heating, or the boiler manufacturer’s literature should indicate that the intended uses of the boiler include heating potable water for purposes other than space heating. A hot water boiler could be fueled by oil or gas, and it must adhere to the minimum thermal efficiency and maximum standby loss as described in California’s *Title 20 Appliance Efficiency Regulations*.

Boilers are typically used for doing both space heating and water heating. Use of a boiler will typically require one or more unfired storage tanks to be installed as part of the system. Careful attention should be given to the layout of these systems due to the potential for high energy losses between the boiler and storage tanks. Boilers are not allowed through the prescriptive approach to compliance but can be installed using the performance approach as long as the water heating energy budget is not exceeded.

5.2.3 Water Heater Maintenance

Water heaters should be maintained according to manufacturer recommendations to ensure proper water heater performance, prolonged useful life, and warranty coverage. If water heaters are not maintained, the useful life of the unit can be shortened and failures that may result may not be covered under the warranty. This section presents the best practices for maintaining the life and efficiency of water heaters.

5.2.3.1 Maintenance of Instantaneous Water Heaters

The primary maintenance activities for instantaneous water heaters are flushing the heat exchanger to remove scale buildup and inspecting and cleaning the inlet water filter screen, which helps minimize the amount of debris or sediment that enters the water heater.

Some manufacturers recommend a maintenance schedule, but the maintenance schedule users deploy may vary based on water quality. In areas with hard water, more frequent maintenance (every two years) is recommended. In areas where the water quality is relatively good, water heater maintenance is recommended every three to four years. Frequent inspection of the inlet water filter screen will enable a user to monitor the amount of sediment entering the water heater. If the filter tends to fill with sediment regularly, then more frequent flushing may be required. Users can also reference local water quality data to determine the level of water quality in their area to help guide maintenance schedules.

To assist in flushing the heat exchanger, manufacturers and plumbers recommend the installation of a drain kit (that is, isolation valves). (See Figure 5-2 below.) The installation of isolation valves on instantaneous units is mandatory in the *Energy Standards* (Section 110.3[c]7 and Section 150.0 [n]4). Isolation valves enable the unit to be isolated from both the inlet cold water and the outlet hot water lines, thereby allowing the heat exchanger to be flushed using a simple procedure. Integral to the kit are hose bibs that allow the flushing hoses to be attached. Instantaneous water heater that has integrated drain ports for servicing are acceptable to meet the requirements of Section 110.3(c)7 and will not require additional isolation valves.

Manufacturers recommend that a licensed professional flush the heat exchanger to avoid potentially damaging the water heater, though some manufacturers sell flush kits so that homeowners can maintain their own water heater. Flush kits consist of a submersible pump, two short hoses, hose connections, and a 5-gallon bucket. These components can be purchased separately or as a preassembled kit. A solution of white vinegar is widely recommended for flushing the heat exchanger as it is food-grade and very effective at removing scale.

In addition to flushing the heat exchanger, manufacturers recommend periodically inspecting and cleaning the inlet water filter screen, which helps minimize the amount of debris or sediment that enters the water heater. This can be done by running the filter screen under hot water and using a brush to remove debris. Replacement of the inlet water filter screen is not necessary unless it is damaged.

Figure 5-2: Isolation Valves

Source: <http://www.brasscraft.com/products.aspx?id=266>

5.2.3.2 Maintenance of Storage Water Heaters

For storage water heaters, the primary maintenance activities consist of draining the tank, inspecting the anode rod, and replacing the anode rod, if necessary. The recommended frequency of regular maintenance varies by manufacturer. Like instantaneous water heaters, the frequency of maintenance depends on water quality. Most manufacturers recommend draining the tank every six months to once per year to remove sediment that has accumulated in the bottom of the tank. Periodic inspections (every six months to once a year) of the burner, venting system, and temperature and pressure relief valves are also recommended by manufacturers.

Manufacturers typically recommend inspecting the anode rod every two years and replacing it when necessary to prolong tank life, but the frequency of inspection depends on local water conditions. If water is soft or a water softener is used, more frequent inspection of the anode is needed as softened water will corrode the sacrificial anode rod at a much faster rate than unsoftened water. If the setup of the water heater prevents an easy removal of the corroded anode rod, then it might be necessary to completely move the tank from the location to replace the anode rod.

5.2.4 Drain Water Heat Recovery Devices

Drain water heat recovery (DWHR) is a technology that captures shower waste heat from the drain line. DWHR devices are counter flow heat exchangers, with cold water entering the building on one side of the device and hot drain water exiting the building on the other.

For the 2019 Title 24 Standards, DWHR is a component of an alternative prescriptive path for multifamily buildings with central water heating. It is also a compliance option for other water heating applications. DWHR technologies are most prevalent and perform best in cold climates in applications with large water heating loads and colder inlet water temperatures. California, being a generally milder climate, will show somewhat diminished performance relative to the preferred applications.

A DHWR device uses the reclaimed heat to preheat potable cold water that is then delivered either to the shower or the water heater. The device can be installed in either an “equal flow” configuration (with preheated water being routed to both the water heater and the shower) or an “unequal flow” configuration (preheated water directed to either the water heater or shower). Figure 5-3 schematically shows the three installation configurations. The energy harvested from a DHWR device is maximized in an equal flow configuration. They are sold in both vertical design configurations, as shown in Figure 5-3, and in horizontal configurations. The two forms each have advantages and disadvantages, which should be evaluated for each potential installation.

To use these systems to comply with Energy Standards, the design and installation must be HERS-verified and meet the Reference Appendix RA4.4.21 requirements.

Figure 5-3: The Three Plumbing Configurations of DHWR Installation (From left to right: Equal Flow, Unequal Flow - Water Heater, Unequal Flow - Fixture)

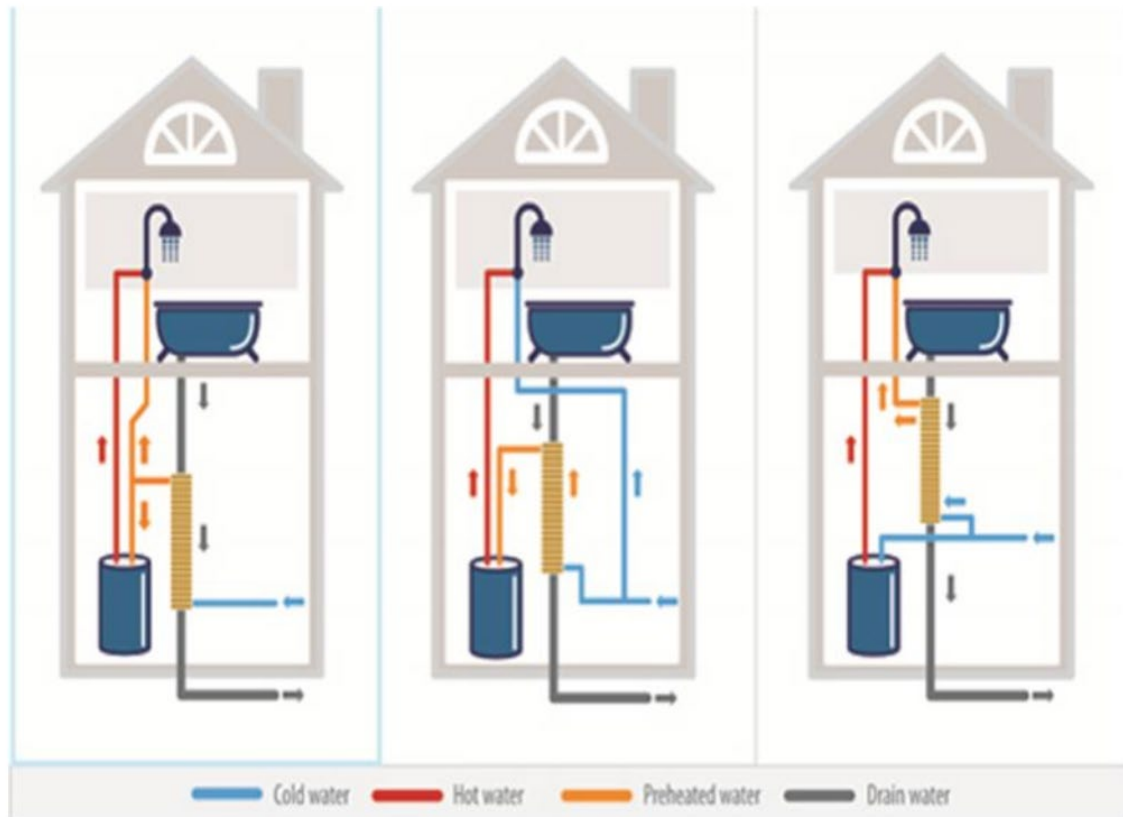

Source: Frontier Energy

5.3 Mandatory Requirements for Water Heating

5.3.1 Equipment Certification

§110.3(a)

Manufacturers must certify that their products comply with California's *Title 20 Appliance Efficiency Regulations*, Section 1605.1(f) at the time of manufacture. Regulated equipment that applies to all of the aforementioned system types in Section 5.2 must be listed in the California Energy Commission Appliance Efficiency Database.

5.3.2 Equipment Efficiency

§110.3(b), §110.1

Water heaters are regulated under California's *Title 20 Appliance Efficiency Regulations*, Section 1605.1(f). These regulations align with the federal efficiency standards for water heaters. Consumer water heaters and residential-duty commercial water heaters are both rated in Uniform Energy Factor (UEF). The draw pattern is based on the water heater's design first hour rating for storage water heater, or gallon per minute for instantaneous water heaters. The efficiency requirements for the most common consumer water heaters are given in Table 5-4 below. The efficiency requirements for the residential-duty commercial water heaters are given in Table 5-5 below.

The Energy Commission has developed a water heater efficiency guide to allow quick lookup of the minimum efficiency of the most common types and sizes of water heaters. It is available to download here:

http://www.energy.ca.gov/title24/orc/waterheating/2019_waterheating.html#resguides.

Table 5-4: Minimum Federal UEF Requirements for Consumer Water Heaters

Product class	Rated storage volume and input rating (if applicable)	Draw pattern	UEF
Gas-fired Storage Water Heater	≥20 gal and ≤55 gal	Very Small	0.3456 – (0.0020 × Vr)
		Low	0.5982 – (0.0019 × Vr)
		Medium	0.6483 – (0.0017 × Vr)
		High	0.6920 – (0.0013 × Vr)
	>55 gal and ≤100 gal	Very Small	0.6470 – (0.0006 × Vr)
		Low	0.7689 – (0.0005 × Vr)
		Medium	0.7897 – (0.0004 × Vr)
		High	0.8072 – (0.0003 × Vr)
Electric Storage Water Heaters	≥20 gal and ≤55 gal	Very Small	0.8808 – (0.0008 × Vr)
		Low	0.9254 – (0.0003 × Vr)
		Medium	0.9307 – (0.0002 × Vr)
		High	0.9349 – (0.0001 × Vr)
	>55 gal and ≤120 gal	Very Small	1.9236 – (0.0011 × Vr)
		Low	2.0440 – (0.0011 × Vr)
		Medium	2.1171 – (0.0011 × Vr)
		High	2.2418 – (0.0011 × Vr)
Instantaneous Gas-fired Water Heater	<2 gal and >50,000 Btu/h	Very Small	0.80
		Low/Medium/High	0.81
Instantaneous Electric Water Heater	<2 gal	Very Small/Low/Medium	0.91
		High	0.92
Grid-Enabled Water Heater	>75 gal	Very Small	1.0136 – (0.0028 × Vr)
		Low	0.9984 – (0.0014 × Vr)
		Medium	0.9853 – (0.0010 × Vr)
		High	0.9720 – (0.0007 × Vr)
Vr= Rated Storage Volume – the water storage capacity of a water heater (in gallons).			

Source: U.S. Department of Energy

Table 5-5: Minimum Federal Uniform Energy Factor Requirements for Residential-Duty Commercial Water Heaters

Product class	Specifications	Draw pattern	UEF
Gas-Fired Storage	>75 kBTU/hr and ≤105 kBTU/hr and ≤120 gal	Very Small	$0.2674 - (0.0009 \times Vr)$
		Low	$0.5362 - (0.0012 \times Vr)$
		Medium	$0.6002 - (0.0011 \times Vr)$
		High	$0.6597 - (0.0009 \times Vr)$
Oil-Fired Storage	>105 kBTU/hr and ≤140 kBTU/hr and ≤120 gal	Very Small	$0.2932 - (0.0015 \times Vr)$
		Low	$0.5596 - (0.0018 \times Vr)$
		Medium	$0.6194 - (0.0016 \times Vr)$
		High	$0.6740 - (0.0013 \times Vr)$
Electric Instantaneous	>12 kW and ≤58.6 kW and ≤2 gal	All draw pattern	0.80

For commercial water heaters, unlike consumer water heaters, these water heaters are not rated in UEF. The required minimum energy efficiency for commercial water heaters are defined as thermal efficiency and standby loss, as shown in Table 5-6 below.

Table 5-6: Minimum Efficiency Requirements for Commercial Water Heaters

<i>Appliance</i>	<i>Input-to-Volume Ratio</i>	<i>Size (Volume)</i>	<i>Minimum Thermal Efficiency (%)</i>	<i>Maximum Standby Loss^{1,2}</i>
Gas storage water heaters	< 4,000 BTU/hr/gal	any	80	$Q/800 + 110(Vr)1/2$ BTU/hr
Gas instantaneous water heaters	≥ 4,000 BTU/hr/gal	< 10 gal	80	–
		≥ 10 gal	80	$Q/800 + 110(Vr)1/2$ BTU/hr
Gas hot water supply boilers	≥ 4,000 BTU/hr/gal	< 10 gal	80	–
		≥ 10 gal	80	$Q/800 + 110(Vr)1/2$ BTU/hr
Oil storage water heaters	< 4,000 BTU/hr/gal	any	78	$Q/800 + 110(Vr)1/2$ BTU/hr
Oil instantaneous water heaters	≥ 4,000 BTU/hr/gal	< 10 gal	80	–
		≥ 10 gal	78	$Q/800 + 110(Vr)1/2$ BTU/hr
Oil hot water supply boilers	≥ 4,000 BTU/hr/gal	< 10 gal	80	–
		≥ 10 gal	78	$Q/800 + 110(Vr)1/2$ BTU/hr
Electric storage water heaters	< 4,000 BTU/hr/gal	any	–	$0.3 + 27/Vm$ %/hr

1. Standby loss is based on a 70° F temperature difference between stored water and ambient requirements. In the standby loss equations, Vr is the rated volume in gallons, Vm is the measured volume in gallons, and Q is the nameplate input rate in BTU/hr.
2. Water heaters and hot water supply boilers having more than 140 gallons of storage capacity are not required to meet the standby loss requirement if the tank surface is thermally insulated to R-12.5, if a standing pilot light is not installed, and for gas- or oil-fired storage water heaters, there is a flue damper or fan-assisted combustion.

Source: California Energy Commission, *Title 20 Appliance Efficiency Regulations* (2014)

5.3.3 Isolation Valves

§110.3(c)7

All newly installed instantaneous water heaters (minimum input of 6.8 kBTU/hr) shall have isolation valves on both the incoming cold water supply and the hot water pipe leaving the water heater. Isolation valves assist in the flushing of the heat exchanger and help prolong the life of instantaneous water heaters. Instantaneous water heater that has integrated drain ports for servicing are acceptable to meet the requirements of §110.3(c)7 and will not require additional isolation valves.

5.3.4 High-Efficiency Water Heater Ready

§150.0(n)

To facilitate future installations of high-efficiency equipment, the Energy Standards contain the following mandatory requirements for systems using gas or propane water heaters that serve individual dwelling units.

These requirements are for new construction and additions (if a water heater is installed in the added floor area), and they are not applicable to alterations. Moreover, these requirements are not applicable when installing an electric water heater.

1. A dedicated 125-volt (V) electrical receptacle that is within 3 feet of the water heater and accessible to the water heater with no obstructions, and be connected to a three conductor, 10 AWG branch circuit. In addition, the unused conductor must be labeled and electrically isolated and have a reserved circuit breaker space.
2. A Category III or IV vent or a Type B vent with a straight pipe between the outside termination and the space where the water heater is installed
3. A condensate drain that is no more than 2 inches higher than the base of the installed water heater and allows natural draining without pump assistance
4. A gas supply line with a capacity to provide at least 200,000 BTU/hr to the water heater.

These requirements make it easier for someone to retrofit HPWH or high efficiency gas water heaters in the future. Virtually all high efficiency gas water heaters require an electrical connection and wiring during initial construction stage is much less costly than trying to retrofit it later.

5.3.4.1 **Electrical Receptacle**

The goal of this requirement is to allow easy installation of HPWH when the existing gas water heater needs to be replaced. HPWH typically requires a 240-volt circuit and this requirement allows an electrician to easily convert the 120-volt circuit to a 240-volt circuit.

The electrical receptacle must be installed with 3 feet from the water heater. It should be connected to a dedicated circuit with a 10 AWG copper branch circuit. The ends of the unused conductor must be labeled as “spare”, and be electrically isolated.

A reserved single pole circuit breaker space must be placed in the electrical panel next to the circuit breaker for the branch circuit and labeled with the words “Future 240V Use.”

5.3.4.2 **Venting**

Table 5-7 below summarizes venting requirements for different types of water heaters. Higher efficiency water heaters often require different vent materials due to the presence of acidic condensation from flue gases. The standard Type B vent installed for conventional atmospheric gas water heaters is made of steel and would soon be destroyed by the condensate. As a result, the Energy Standards require that a Type B vent for the water heater can be installed only when there is a straight shot between the water heater and where the vent leaves the building. There should be no bends along the path of the Type B vent, except the portion of the Type B vent outside the building and in the space where the water heater is installed. The installation shall meet all code and manufacturers' guidelines. Because Category III and IV pipes are usually smaller

than those for Type B vents, a straight Type B vent can be easily modified into a Category III or IV vent by simply inserting a new vent pipe through the existing Type B vent pipe. A flue pipe that makes bends through the building structure is not easy to retrofit, and, thus, these flues must be either Category III or IV vent pipes. Only stainless steel Category III and IV vents are compatible with typical atmospheric combustion storage water heaters.

Table 5-7: Summary of Acceptable Vent Material by Appliance Category

<i>Appliance Venting Category</i>	<i>Vent Pressure</i>	<i>Condensing or Non-Condensing</i>	<i>Common Vent Pipe Material</i>
Category I: An appliance that operates with a nonpositive vent static pressure and with a vent gas temperature that avoids excessive condensate production in the vent	Nonpositive; atmospheric-vented; gravity-vented; most common category of gas-fired water heaters.	Noncondensing (typically less than 82% efficiency)	Metal double wall "B" vent
Category II: An appliance that operates with a nonpositive vent static pressure and with a vent gas temperature that may cause excessive condensate production in the vent	Nonpositive	Condensing	Special venting material per the product manufacturer
Category III: An appliance that operates with a positive vent static pressure and with a vent gas temperature that avoids excessive condensate production in the vent	Positive (usually created by a blower motor); generally cannot be adjoined to gravity-vented water heater.	Noncondensing (typically less than 82% efficiency)	Stainless steel; these usually require 3" clearance to combustibles and the joints must be sealed air tight.
Category IV: An appliance that operates with a positive vent static pressure and with a vent gas temperature that avoids excessive condensate production in the vent	Positive (usually created by a blower motor); generally cannot be adjoined to gravity-vented water heater.	Condensing	Plastic pipe (PVC, CPVC, ABS, etc.)

5.3.4.3 Condensate Drain

The requirement for the condensate drain being placed near the water heater and no higher than the base of the tank allows the condensate to be removed without relying on a sump pump.

5.3.4.4 Gas Line

Designing the gas line to provide 200,000 BTU per hour gas supply capacity to the water heater is required to accommodate future retrofit to a gas instantaneous water heater, which usually has a heat input capacity of 199,000 BTU/hr or higher. Similar to the electrical requirement, installing a larger gas line during new construction is inexpensive relative to a future gas line retrofit.

Gas pipe sizing for the building needs to consider piping layout and gas supply requirements for other gas appliances, such as gas clothes dryers, gas furnaces, gas ranges and ovens, and gas fireplace burners. The traditional practice of using a ½-inch gas pipe in a single-family house to serve a storage water heater is **not** in compliance with the mandatory requirement. The minimum gas pipe size for water heaters is ¾-inch. The exact gas piping system should be designed following the California Plumbing Code.

5.3.5 Mandatory Requirements for Hot Water Distribution Systems

5.3.5.1 Pipe Insulation for All Buildings

§150.0(j)2

All domestic hot water piping shall be insulated as specified in Section 609.11 of the California Plumbing Code, which requires pipe insulation thickness equal to or more than the diameter of the pipe, up to 2 inches. Above pipe diameter of 2 inches, the insulation thickness must be at least 2 inches. In addition, the following piping conditions shall have a minimum insulation wall thickness of 1 inch:

1. The first 5 feet of hot and cold water pipes from the storage tank or water heater.
2. All piping with a nominal diameter of $\frac{3}{4}$ inch or larger.
3. All piping associated within a domestic hot water recirculation system regardless of the pipe diameter. This excludes branches off the recirculation loop that are less than $\frac{3}{4}$ inch diameter or do not serve the kitchen.
4. Piping from the heating source to a storage tank or between tanks.
5. Piping buried below grade.
6. All hot water pipes from the heating source to the kitchen fixtures.

In addition to insulation requirements, all domestic hot water pipes that are buried below grade must be installed in a waterproof and noncrushable casing or sleeve. The installation shown in Figure 5-4 below would not meet the installation requirements since it is not insulated. In addition, in Figure 5-4 the hot and cold water lines are not separated. Heat transfer will occur, resulting in energy loss and causing condensation on the cold water line.

Figure 5-4: Noncompliant Below-Grade Piping and Hot and Cold Water Lines Separation

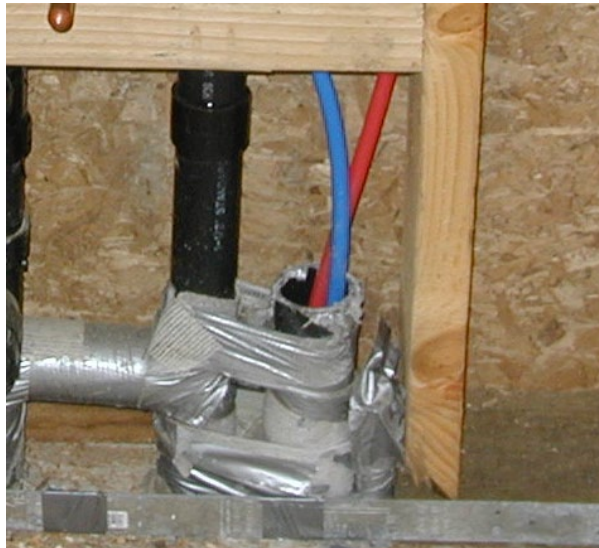

Source: Davis Energy Group/Frontier Energy

A. Piping exempt From the Mandatory Insulation Includes:

1. Factory-installed piping within space conditioning equipment.

2. Piping that serves process loads, gas piping, cold domestic water piping (other than within 5 feet of the water heater), condensate drains, roof drains, vents, or waste piping.
3. Piping that penetrates framing members. This piping is not required to have insulation where it penetrates the framing. However, if the framing is metal, then some insulating material must prevent contact between the pipe and the metal framing.
4. Piping located within exterior walls that are installed so that piping is placed inside wall insulation. Wall insulation may be an acceptable alternative insulation method for sections of pipes that would otherwise need pipe insulation, as long as the wall insulation in the walls where the pipes are located meets the requirements of QII and the pipes are roughly centered in the wall cavity. (see Reference Appendix RA4.4.1).
5. Piping in the attic continuously buried by at least 4 inches of blown-in ceiling insulation. Piping may not be placed directly in contact with sheetrock and then covered with insulation to meet this requirement.

B. Other installation information:

1. No insulation should be installed closer than 6 inches from the flue. If possible, bend the pipe away from the flue. Otherwise, it may be necessary to stop pipe insulation short of the storage tank. (See the current version of the California Mechanical Code.)
2. All pipe insulation seams must be sealed.
3. Installed piping may not be located in supply or return air plenums. (See the current version of the California Mechanical Code.)
4. Hot and cold water piping, when installed in parallel runs, must be at least 2 inches apart. (See Reference Appendix RA4.)
5. If a fire wall interrupts the first 5 feet of pipe, the insulation may be interrupted at the wall and continued on the other side.
6. Insulation for pipe elbows should be mitered and insulation for tees should be notched. (See Reference Appendix RA4.)

Figure 5-5: Pipe Insulation Requirements First Five Feet From Water Heater

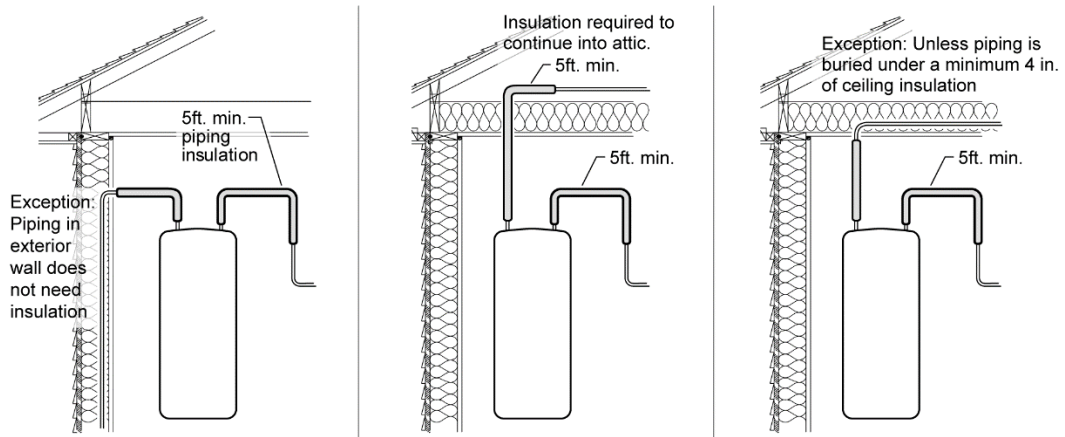

Source: California Energy Commission

Table 5-8: Pipe Insulation Thickness Requirement

Fluid Operating Temperature Range (°F)	Insulation Conductivity			Nominal Pipe Diameter (in inches)				
	Conductivity (in Btu-in/h-ft ² -°F)	Mean Rating Temperature (°F)		< 1	1 to <1.5	1.5 to < 4	4 to < 8	8 and larger
Space heating and Service Water Heating Systems (Steam, Steam Condensate, Refrigerant, Space Heating, Service Hot Water)				Minimum Pipe Insulation Required (Thickness in inches or R-value)				
Above 350	0.32-0.34	250	Inches	4.5	5.0	5.0	5.0	5.0
			R-value	R 37	R 41	R 37	R 27	R 23
251-350	0.29-0.32	200	Inches	3.0	4.0	4.5	4.5	4.5
			R-value	R 24	R 34	R 35	R 26	R 22
201-250	0.27-0.30	150	Inches	2.5	2.5	2.5	3.0	3.0
			R-value	R 21	R 20	R 17.5	R 17	R 14.5
141-200	0.25-0.29	125	Inches	1.5	1.5	2.0	2.0	2.0
			R-value	R 11.5	R 11	R 14	R 11	R 10
105-140	0.22-0.28	100	Inches	1.0	1.5	1.5	1.5	1.5
			R-value	R 7.7	R 12.5	R 11	R 9	R 8

Source Excerpt From Table 120.3-A of the Energy Standards

Where insulation is required as described above, 1 inch of insulation is typically required. This requirement applies to domestic hot water pipe (above 105° F) when the pipe diameter is 1 inch or smaller, the water temperature is between 105°F and 140°F, and the insulation conductivity is between 0.22 and 0.28 BTU-in/hr-ft²-°F (typical of cellular foam pipe insulation material). One and one-half inch insulation is required on pipes greater than 1 inch. For other situations refer to Table 120.3-A.

5.3.5.2 Insulation Protection

§150.0(j)3

If hot water piping insulation is exposed to weather, it must be protected from physical damage, ultraviolet (UV) light deterioration, and moisture. Insulation is typically protected by aluminum, sheet metal, painted canvas, plastic cover, or a water-retardant coating that shields from solar radiation. Adhesive tape should not be used as insulation cover because removal of the tape will damage the integrity of the original insulation during preventive maintenance.

5.3.5.3 Distribution Systems Serving Multiple Dwelling Units – With Recirculation Loops

§110.3(c)5

Multifamily buildings may have water heaters for each dwelling unit but are more likely to have a central water heating system with a recirculation loop that supplies each of the units. This recirculation loop consists of a supply portion of larger diameter pipe connected to smaller diameter branches that serve multiple dwelling units, guest rooms, or common area fixtures and a return portion that completes the loop back to the water heating equipment. The large volume of water that is recirculated during periods of high use creates situations that require the installation of certain controls and servicing mechanisms to optimize performance and allow for lower cost of maintenance. The following paragraphs cover the mandatory requirements for system serving multiple dwelling units and with recirculation loops.

A. Air Release Valves

§110.3(c)5A

The constant supply of new water in combination with the continuous operation of pumps creates the possibility of the pump cavitation due to the presence of air in the water. *Cavitation* is the formation of bubbles in the low-pressure liquid on the suction side of the pump. The cavities or bubbles will collapse when they pass into the higher regions of pressure, causing noise and vibration that may lead to damage to many of the components. In addition, there is a loss in capacity, and the pump can no longer build the same head (pressure). This ultimately affects the efficiency and life expectancy of the pump.

Cavitation shall be minimized either by installing an air release valve or mounting the pump vertically. The air release valve must be located no more than 4 feet from the inlet of the pump. The air release valve must also be mounted on a vertical riser with a length of at least 12 inches.

B. Backflow Prevention**§110.3(c)5B**

Temperature and pressure differences in the water throughout a recirculation system can create backflows. This can result in cooler water from the bottom of the water heater tank and water near the end of the recirculation loop flowing backward toward the hot water load and reducing the delivered water temperature.

To prevent this from occurring, the Energy Standards require that a check valve or similar device be located between the recirculation pump and the water heating equipment.

C. Equipment for Pump Priming/Pump Isolation Valves**§110.3(c)5C&D**

A large number of systems are allowed to operate until complete failure simply because of the difficulty of repair or servicing. Repair labor costs can be reduced significantly by planning and designing for easy pump replacement when the pump fails. Provision for pump priming and pump isolation valves helps reduce maintenance costs.

To meet the pump priming equipment requirement, a hose bib must be installed between the pump and the water heater. In addition, an isolation valve shall be installed between the hose bib and the water heating equipment. This configuration will allow the flow from the water heater to be shut off, allowing the hose bib to be used for bleeding air out of the pump after pump replacement.

The requirement for the pump isolation valves will allow replacement of the pump without draining a large portion of the system. The isolation valves shall be installed on both sides of the pump. These valves may be part of the flange that attaches the pump to the pipe. One of the isolation valves may be the same isolation valve as in Item C.

D. Connection of Recirculation Lines**§110.3(c)5E**

Manufacturer's specifications should always be followed to assure optimal performance of the system. The cold water piping and the recirculation loop piping should never be connected to the hot water storage tank drain port.

E. Backflow Prevention in Cold Water Supply**§110.3(c)5F**

The dynamic between the water in the heater and the cold water supply are similar to those in the recirculation loop. Thermosiphoning can occur on this side of this loop just as it does on the recirculation side of the system. To prevent this, the Energy Standards require a check valve to be installed on the cold water supply line. The valve should be located between the hot water system and the next closest tee on the

cold water supply line. The system shall comply with the expansion tank requirements as described in the California Plumbing Code.

Figure 5-6: Mandatory Central Recirculation System Installation Requirements

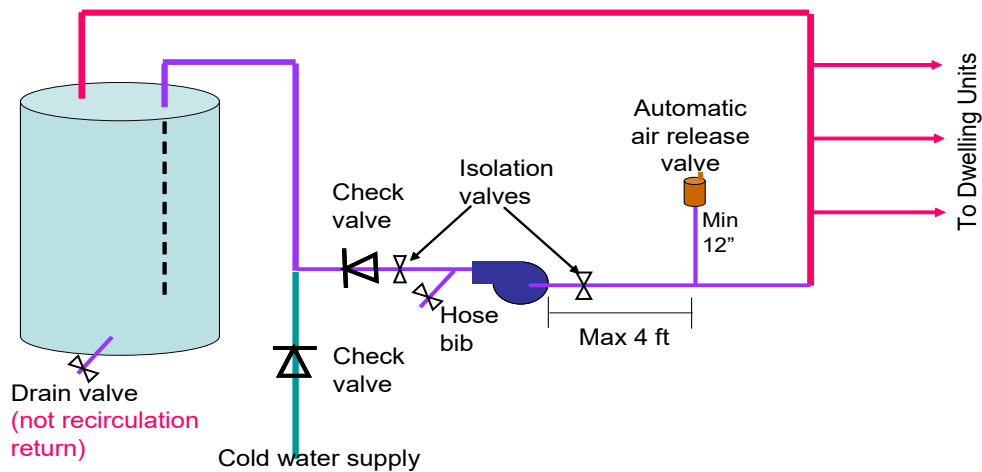

Source: California Energy Commission

Example 5-1 – Distribution Systems

Question:

When I'm insulating the pipes for a recirculating water heating system, I understand that I must insulate the entire length of hot water pipes that are part of the recirculation loop. Do I also need to insulate the runouts?

Answer:

No, other than the pipe to the kitchen fixture as it is a mandatory requirement. Since the water in runouts does not recirculate, other runouts do not need to be insulated.

Example 5-2 – Recirculation System Insulation

Question:

Can I get pipe insulation credit for a recirculating water heating system?

Answer:

Not for systems serving a single dwelling unit. Recirculating water heating systems have a mandatory insulation requirement for the recirculating section of the hot water pipes; pipes less than 1 inch must be insulated to 1 inch of insulation. For systems serving multiple dwelling units, using thicker-than-required insulation results in credit within the performance approach. All the circulation loop pipes in one location type (for example, inside, outside, underground) must be insulated to the higher level to qualify.

Example 5-3 – Pipe Insulation**Question:**

I thought I was supposed to insulate hot and cold water piping from the water heater for either the first 5 feet or the length of piping before coming to a wall, whichever is less. Did I misunderstand?

Answer:

Yes. The requirement is that you must insulate the entire length of the first 5 ft, regardless of whether there is a wall (§150.0[j]2). You have two options: (1) interrupt insulation for a fire wall and continue it on the other side of the wall or (2) run the pipe through an insulated wall, making sure that the wall insulation completely surrounds the pipe. The reason for insulating the cold line is that when heated, the water inside the water heater expands and pushes hot water out the cold water line. The first several feet of the cold water pipe near the water heater can be warm and insulation reduces the heat loss from the first 5 feet of the cold water piping

5.4 Prescriptive Requirements for Water Heating**5.4.1 Single Dwelling Units****§150.1(c)8**

There are five options to comply with the prescriptive water heating requirements for newly constructed single dwelling units. For all five options, the water heater must comply with the mandatory requirements for water heaters. (See Section 5.3.) If a recirculation distribution system is installed, only demand recirculation systems with manual control pumps are allowed. The five options are described below.

Option 1: Install one or more natural gas or propane instantaneous water heater with an input rating of 200,000 BTU per hour or less and no storage tank.

Option 2: Install a single natural gas or propane storage water heater with a rated storage volume 55 gallons or less and an input rating of 75,000 BTU per hour or less. In addition, the dwelling unit shall have installed fenestration products with a weighted average U- factor no greater than 0.24, as well as one of the following requirements

1. Use a compact hot water distribution design, which requires a HERS Rater to verify that the system has been designed and installed in accordance with the Energy Standards (See Reference Appendix RA4.4.16.)
2. Use a drain water heat recovery system, which requires a HERS Rater to verify that the system has been designed and installed in accordance with the Energy Standards (See Reference Appendix RA4.4.21.)

- Option 3: Install a single natural gas or propane storage water heater with a rated storage volume greater than 55 gallons and an input rating of 75,000 BTU per hour or less.
- Option 4: Install a single heat pump water heater. The storage tank shall be located in the garage or conditioned space. In addition, the building must comply with one of the following:
1. A compact hot water distribution design earning the Basic Compact Design –credit and a HERS-verified drain water heat recovery system.
 2. For Climate Zones 2 through 15, a photovoltaic system capacity of 0.3 kW direct current (dc) larger than the requirement specified in Section 150.1(c)14.
 3. For Climate Zones 1 and 16, a photovoltaic system capacity of 1.1 kWdc larger than the requirement specified in Section 150.1(c)14.
- Option 5: Install a single heat pump water heater that meets the requirements of NEEA Advanced Water Heater Specification Tier 3 or higher. The storage tank shall be located in the garage or conditioned space. In addition, for Climate Zones 1 and 16, a photovoltaic system capacity of 0.3 kWdc larger than the requirement specified in §150.1(c)14 or a compact hot water distribution system earning the Basic Compact Design credit.

If Option 2, 4, or 5 is pursued, then one or more additional building features must be installed as shown above. These features require consideration at the start of the design process, and must be coordinated with several players including the designer, general contractor, sub-contractor, and HERS Rater.

The list of qualified product list of NEEA HPWH can be found here:

<https://neea.org/img/documents/qualified-products-list.pdf>

For more information on HERS-verified compact hot water distribution design, see Section 5.6.2.4. HERS-verified compact hot water distribution designs are included in Options 2 described above.

For more information on HERS-verified drain water heat recovery system requirements, see Example 5-9 below and Section 5.6.2.5 of this chapter. The Reference Appendix contains the requirements for the proper installation of the system (see RA4.4.21). A HERS-verified drain water heat recovery system is included in Options 2 and 4 described above.

Any other water heating system that differs from the five options described in this section does not meet the prescriptive requirements. Other systems can be installed if using the performance approach as described in Section 5.5.

For additions, the prescriptive requirements described above apply only if a water heater is being installed as part of the addition. The prescriptive requirements apply only to the space that is added, not the entire building.

For alterations where an existing water heater is being replaced, the water heater must meet the mandatory equipment efficiency requirements. Pipe insulation requirements do not apply to alteration for the portion of the pipes that are inaccessible. See Chapter 9 for a more detailed explanation for the water heating alteration requirements.

Example 5-4 – Single-Family Home With Multiple Water Heaters**Question:**

A newly built 6,000-ft² single-family home has three gas storage water heaters (40-gallon, 30-gallon, and a 100-gallon unit with 80,000 BTU/h input). Does it comply?

Answer:

In most cases, multiple storage water heaters will result in greater energy consumption than the standard design case (one water heater for a new single-family home). As such, a performance calculation is required since the system does not meet the standard requirements and must be shown to meet the water heating energy budget. However, multiple instantaneous gas water heaters are allowed under Option 1 of the prescriptive method and this house can meet compliance by going that route.

Example 5-5 – Alterations**Question:**

If my house has an electric-resistance water heater and I plan to upgrade my water heater, do I need to install a gas instantaneous or gas storage water heater?

Answer

No, if natural gas is not already connected to the existing water heater location, then a consumer electric water heater that meets the requirements of California's Appliance Efficiency Regulations can replace the existing water heater. If installing new piping to the water heater, then you will need to comply with the mandatory pipe insulation requirements. See Section 5.3.5.1 for more information on pipe insulation requirement and Chapter 9 for more information on alterations.

Example 5-6– Additions**Question:**

I am building an addition to my home that will be a self-contained apartment. Do I need to comply with the prescriptive requirements?

Answer:

If the addition will include a water heater, or if it will be connected to the existing hot water distribution system to supply hot water to the apartment, then you must comply with the standards either through the prescriptive or performance path. If taking the performance approach, you can install any type of water heater as long as it 1) meets the requirements of California's *Appliance Efficiency Regulations* and 2) does not exceed the water heating energy budget for the self-contained building. If you were adding only an additional room with hot water and not a self-contained dwelling, then the water heating budget would be based on the existing building plus addition. (See Section 5.5.)

Example 5-7 – Heat Pump Water Heaters

Question:

For a new home, can I install an electric water heater? Do I have to perform calculations to show compliance?

Answer:

Yes, electric heat pump water heater (HPWH) can be used for both prescriptive and performance compliance. Calculation is not necessary using the prescriptive compliance path. There are 2 prescriptive options (Option 4 and 5 in Section 5.4.1 above) for HPWH. Option 5 is the simplest option, which requires the installation of a NEEA Tier 3 or higher HPWH in the garage or conditioned space. For climate zones 2 through 15, no additional requirement is needed for compliance. For climate zones 1 and 16, an additional 0.3 kWdc is required in addition to the prescriptive photovoltaic requirement. For more details, see Section 5.4.1 above.

For performance compliance, the characteristic of the HPWH must be modeled, such as rated UEF or make and model of the HPWH if it is NEEA rated.

Example 5-8 – Drain Water Heat Recovery

Question:

I'm in the schematic design phase for a single-family home. I intend to include drain water heat recovery in my design and to follow the prescriptive path. What are the primary design issues I should consider?

Answer:

If you follow the prescriptive path, drain water heat recovery aids compliance only if you are specifying a gas or propane storage water heater with a rated storage volume of 55 gallons or less; or a heat pump water heater that does not meet or exceed NEEA Advanced Water Heater Specification Tier 3. For all water heater type, you could follow the performance path and obtain compliance credit within an energy model calculation. In any case, the initial design issues are related to the selection of an appropriate drain water heat recovery model (i.e. horizontal or vertical type, minimum rated effectiveness, and diameter and length), and designing the layout of the system. If your residence is single story, then a horizontally rated unit is required. If your residence has multiple stories, then the unit can be horizontally or vertically rated. In any case, the required minimum rated effectiveness is 42 percent. The diameter of the unit should match the diameter of the drain pipe. Added length improves effectiveness but requires more space. In terms of the system layout, the unit must recover heat from at least the master bathroom shower and must at least transfer that heat either back to all the respective showers or the water heater. If you desire to maximize savings, you should place the unit in a drain line that serves all the showers and you should pipe the preheated water to the cold side of all the shower mixing valves and the make-up water inlet of the water heater. This is known as an *equal flow* configuration, since the preheated water flow rate will match the drain water flow rate.

5.4.2 Multiple Dwelling Units: Multifamily, Motel/Hotels, and High-Rise Residential

§150.1(c)8

There are two options for using the prescriptive approach to compliance for multifamily buildings:

1. A water heater must be installed in each unit that meets the requirements for a single-family building.
2. A central gas or propane-fired water heater or boiler.

The water heater must have an efficiency that meets the requirements in §110.1 and §110.3 (as listed in Table 5-5). In addition, if a central recirculation system is installed, it shall be installed with demand recirculation controls and a distribution layout with at least two recirculation loops. These prescriptive rules were developed based on studies that found that recirculation pipe heat loss is a major component of energy loss within a central hot water system. Pipe heat loss is affected by the pipe surface area, pipe insulation level, and the temperature difference between the hot water and ambient air. The motivation behind having two loops is to reduce recirculation pipe sizes, thus pipe surface area. This measure reduces energy use and piping materials associated with recirculation systems. Central water heating systems with eight or fewer dwelling units are exempted from needing two recirculation loops.

5.4.2.1 Dual-Loop Recirculation System Design

§150.1(c)8Cii

A dual-loop design is illustrated in Figure 5-7. In a dual loop design, each loop serves half of the dwelling units. According to plumbing code requirements, the pipe diameters can be downsized compared to a loop serving all dwelling units. The total pipe surface area is effectively reduced, even though total pipe length is about the same as or somewhat greater than that of a single-loop design. For appropriate pipe sizing guidelines, please refer to the Universal Plumbing Code.

Figure 5-7: Example of a Dual-Loop Recirculation System

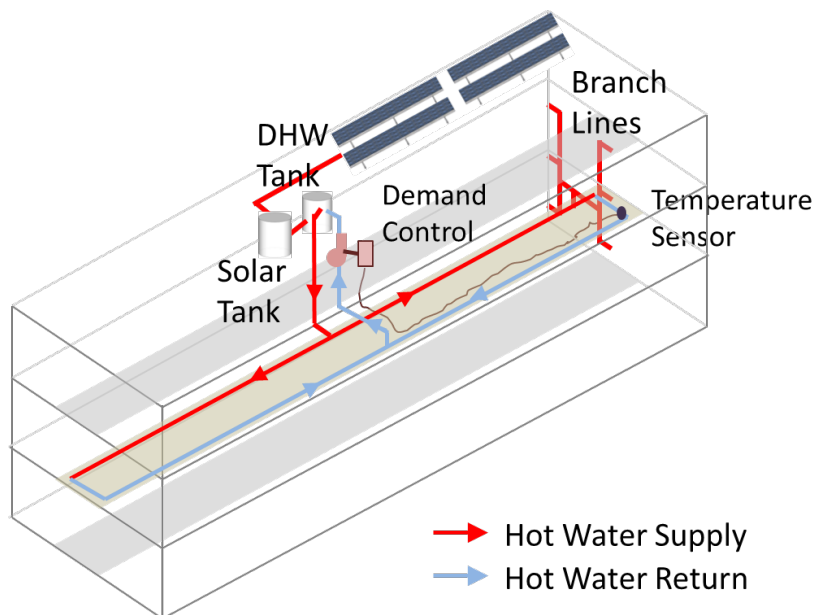

Source: 2013 CASE Initiative: Multifamily Central DHW and Solar Water Heating

Figure 5-7 provides an example of how to implement dual loop design in a low-rise multifamily building with a simple layout. In this example, the water heating equipment is in the middle of the top floor with each recirculation loop serving exactly half of the building. The recirculation loops are located in the middle floor to minimize branch pipe length to each dwelling unit. The figure also illustrates how the solar water heating system and demand controls are integrated.

For buildings with complicated layouts, how to create and locate recirculation loops heavily depends on building geometry. In general, the system should be designed to have each loop serve an equal number of dwelling units to minimize pipe sizes. For systems serving buildings with distinct sections, for example, two wings in an L-shaped building, it is better to dedicate a separate recirculation loop to each of the sections. Very large buildings and buildings with more than two sections should consider using separate central water heating systems for each section. In all cases, simple routing of recirculation loops should be used to keep recirculation pipes and runouts as short as

possible. Figure 5-8 provides dual-loop recirculation system designs in buildings with complicated shapes.

Figure 5-8: Examples of Dual-Loop Recirculation System Designs in Buildings of Complicated Shapes

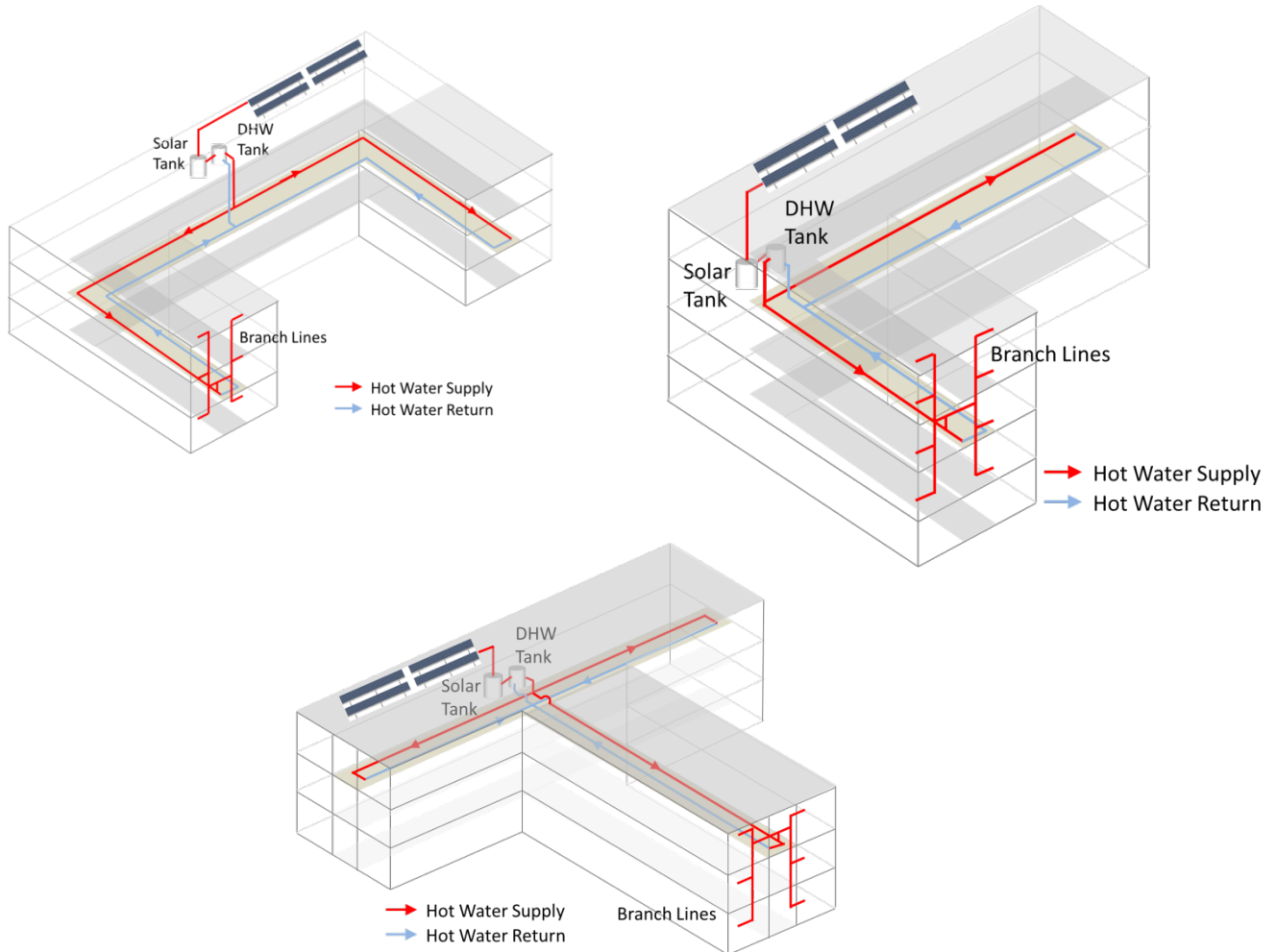

Source: 2013 CASE Initiative: Multifamily Central DHW and Solar Water Heating

Location of water heating equipment in the building also needs to be carefully considered to properly implement the dual-loop design. The goal is to keep overall pipe length as short as possible. As an example, for buildings in regular shapes, locating the water heating equipment at the center of the building footprint rather than at one end of the building helps minimize the pipe length needed to connect the water heating equipment to the two loops. If a water heating system serves several building sections, the water heating equipment would preferably nest between these sections.

With the new prescriptive solar water heating requirement this cycle, it is especially important to consider the integration between the hot water recirculation system and the solar water heating system. Based on feedback from industry stakeholders, most

solar water heating systems are configured only as a preheater of the primary gas water heating equipment. In other words, recirculation hot water returns are usually plumbed back to the gas water heating storage tanks, not directly into the solar tank. This means recirculation loop designs should be based mostly on the building layout and are relatively independent of the solar water heating system. On the other hand, gas water heating equipment and solar tanks should be located close to each other to avoid heat loss from pipes connecting the two systems. The preferred configuration is to place both the gas water heating equipment and solar tanks on the top floor near the solar collector so that the total system pipe length can be reduced. As noted before, minimizing pipe length helps reduce domestic hot water system energy use as well as system plumbing cost.

5.4.2.2 Demand Recirculation Control

The prescriptive requirement for domestic hot water systems serving multiple dwelling units requires the installation of a demand recirculation control to minimize pump operation and heat loss from pipes. They are different from the demand controls used in single dwelling units. Demand controls for central recirculation systems operate by sensing hot water demand and recirculation return temperatures. The temperature sensor should be installed at the farthest end of the recirculation loop close to the last branch pipe.

Any system not meeting these prescriptive requirements must instead meet the standard design building energy budget that is established by the energy efficiency performance of a gas instantaneous water heater that meets the requirements of California's *Title 20 Appliance Efficiency Regulations* or must follow the performance compliance method for the building as a whole.

Example 5-9 - Multifamily With Individual Water Heater

Question:

We are building a 20-unit multifamily building with individual water heater in each dwelling. Can electric water heaters be used?

Answer:

When there is a water heater in each multifamily dwelling, the requirement is the same as a single-family home. In this situation electric heat pump water heaters (HPWH) can be used for both prescriptive and performance compliance. For more details, see Example 5-7 and Section 5.4.1 above.

Example 5-10 – Multifamily Recirculation System

Question:

We are building an eight-unit, 7,800 ft² multifamily building with a 200-gallon storage gas water heater and a time- and temperature-controlled recirculation system that has 1 inch of insulation on all the piping. The system serves all the units. Do I have to perform calculations to show compliance?

Answer:

Water-heating calculations are required since the standard design assumption uses demand recirculation for the control strategy for central recirculation. Furthermore, solar water heating is a prescriptive requirement for all multifamily buildings with central recirculation systems.

Example 5-11 – Multifamily Large Water Heater**Question:**

We are building a 10-unit apartment building with a single large water heater. We do not plan to install a recirculation pump and loop. Does this meet the prescriptive requirements?

Answer:

No. Since it is unlikely that a nonrecirculating system will satisfactorily supply hot water to meet the tenants' needs, either a recirculating system or individual water heaters must be installed to meet the prescriptive requirements. There is an exception for multifamily buildings of 8 units or fewer.

5.5 Performance Approach Compliance for Water Heating**5.5.1 Energy Budget Calculation**

The computer performance approach allows for the modeling of water heating system performance by taking into account building characteristics, climate, system type, efficiency, and fuel type. The standard design water heating budget is defined by the corresponding prescriptive requirements. The performance method allows for modeling alternative water heater and distribution system combinations. Some of these options will offer compliance credits, and others will result in penalties.

5.5.2 Systems Serving a Single Dwelling Unit

In the case of single dwelling units, any type or number of water heaters supported by the software can be installed. The calculated energy use of the proposed design is compared to the standard design energy budget based on either a single gas instantaneous water heater for gas water heaters with a standard distribution system, or a HPWH with compact distribution system and drain water heat recovery. Adding multiple water heaters to a single-family design will generally result in an energy penalty in the water heating budget that must be offset elsewhere in the total energy budget.

A standard distribution system serving a single dwelling unit does not incorporate a pump for hot water recirculation and does not take credit for any additional DHW design features. All mandatory pipe insulation requirements must be met, such as insulating all pipes running to the kitchen. Alternative distribution systems are compared to the standard design case by using distribution system multipliers (DSMs), which effectively rate alternative options.

Table 5-9 lists all the recognized distribution systems that can be used in the performance approach with the assigned distribution multiplier. The standard distribution system has a multiplier of 1.0. Distribution systems with a multiplier less than 1 represent an energy credit, while distribution systems with a multiplier greater than 1 are counted as an energy penalty. For example, pipe Insulation with HERS Inspection Required (PIC-H) has a multiplier of 0.8. That means that it is modeled at 20 percent less distribution loss than the standard distribution system. For more information or installation requirements on any of the systems, refer to Section 5.6.

Table 5-9: Applicability of Distribution Systems Options Within a Dwelling Unit

<i>Distribution System Types</i>	<i>Assigned Distribution System Multiplier</i>	<i>Systems Serving a Single Dwelling Unit</i>	<i>Multifamily With Central Recirculation Systems</i>
No HERS Inspection Required			
Trunk and Branch -Standard (STD)	1.0	Yes	Yes
Compact Design – Basic (CHWDS)	0.7	Yes	
Parallel Piping (PP)	1.1	Yes	--
Point of Use (POU)	0.3	Yes	--
Recirculation: Non-Demand Control Options (R-ND)	9.8	Yes	--
Recirculation with Manual Demand Control (R-Dman)	1.75	Yes	Yes
Recirculation with Motion Sensor Demand Control (R-DAuto)	2.6	Yes	--
HERS Inspection Required			
Pipe Insulation (PIC-H)	0.85	Yes	Yes
Parallel Piping with 5' maximum length (PP-H)	1	Yes	--
Compact Design - Expanded (CHWDS-H)	0.3 – 0.7 ¹	Yes	--
Recirculation with Manual Demand Control (R-Drmc-H)	1.6	Yes	--
Recirculation with Motion Sensor Demand Control (RDRsc-H)	2.4	Yes	--
<i>1. The multiplier for the Compact Design – Expanded credit varies depending on the home’s floorplan and water heater location. See Section 5.6.2.4 for more information.</i>			

5.5.3 Systems Serving Multiple Dwelling Units

For systems serving multiple dwelling units with a recirculating pump, the standard distribution system design is based on a central recirculation system with two recirculation loops that are controlled by a demand control technology. Systems

designed with other options are allowed, but they require compliance verification through performance calculation.

Central recirculation systems using only one recirculation loop are expected to have larger pipe surface areas than those of dual-loop designs, according to plumbing code requirements for pipe sizing. For large buildings, it may be better to use more than one recirculation loop with each serving a small portion of the building, even though additional credit for designs with more than two recirculation loops is not provided.

If demand control is not used, temperature modulation controls and/or continuous monitoring should be used as an alternative compliance method. Recirculation timer controls are not given any control credits because field studies revealed that they are usually not properly configured to achieve the intended purposes. Buildings with uncontrolled recirculation systems will have to install other efficiency measures to meet compliance requirements through the performance method.

Systems with all pipes insulated can claim compliance credit. The amount of credit is increased if the insulation is verified by a HERS Rater. Increasing recirculation pipe insulation by 0.5 inch above the mandatory requirements can also result in compliance credit through performance calculation.

5.5.4 Treatment of Water Heater Efficiency

For information on how water heater efficiency is considered in terms of modeling energy performance using the compliance software tool, please refer to the *Residential Alternative Calculation Method (ACM) Reference Manual*.

5.5.5 Compliance Issues

Water heating is becoming more important to overall building compliance as building envelope performance and mechanical efficiency improve. When the performance approach is used, a high-efficiency water heater and an efficient distribution system can significantly affect the overall performance margin of a building, especially in the milder climates like Climate Zones 4 through 9, where water heating typically represents a larger fraction of the overall energy budget.

Asking for a cut sheet on the installed equipment to verify efficiency is a simple shortcut to checking compliance. When used in a combined hydronic system, it is important to check the capacity of the system to verify that both space and water heating loads can be met.

5.6 Distribution Systems

5.6.1 Types of Water Heating Distribution Systems

The water heating distribution system is the configuration of piping (and pumps and controls in the case of recirculating systems) that delivers hot water from the water heater to the end-use points within the building. For systems designed for single-family buildings or individual dwelling units in a multifamily building, the system will resemble one of the system types described below under dwelling unit distribution systems. In multifamily buildings, the use of a central water heater and central recirculation

distribution system that brings hot water close to all the dwelling units is also common. A description of the recognized systems for serving single and multiple dwelling units are listed in the following two sections. The installation of a hot water distribution system that does not meet all the installation guidelines discussed in this compliance manual and in the Reference Appendix RA3 and RA4 must have either the deficiencies corrected or compliance calculations using the performance approach assuming that the installed distribution system is substandard. In all cases, the locations of the water heaters and fixtures should be given consideration at the beginning of building design. By minimizing the length of distribution piping, energy use, water waste, wait time for hot water and construction cost can all be reduced.

5.6.2 Systems Serving a Single Dwelling Unit

5.6.2.1 Standard Distribution System (Trunk-and-Branch and Mini-manifold Configurations)

The most basic plumbing layout, and assumed as the reference design in the performance approach, is represented by the conventional trunk-and-branch layout. This layout of a trunk-and-branch system may include one or more trunks, each serving a portion of the building. The trunks are subdivided by branches that serve specific rooms, and these are in turn divided into twigs that serve a particular point of use. This distribution system class includes mini-manifold layouts (Figure 5-9), which incorporate trunk lines that feed remote manifolds that then distribute water via twigs to the end-use points. A standard distribution system cannot incorporate a pump for hot water recirculation. Piping cannot be run up to the attic and then down to points of use on the first floor.

Figure 5-9: Mini-manifold Configuration



- *Installation Criteria and Guidelines*

No pumps may be used to recirculate hot water with the standard distribution system. All applicable mandatory features must be met. When designing a trunk-and-branch system, the concern is keeping all segments of the system as short and as small a

diameter as possible. Even an insulated pipe will lose most of the stored heat within 30 minutes. The other issue to consider is that if hot water gets into a cold water line, all the water in the pipe must be discharged, and up to an additional third of the volume of hot water will be needed to heat the pipe so that the water arriving at the point of use will be the desirable temperature. The requirements and guidelines for the installation of the standard distribution system are included in Reference Appendix RA3 - Residential Field Verification and Diagnostic Testing Protocols and RA4 - Eligibility Criteria for Energy Efficiency Measures.

5.6.2.2 Central Parallel Piping System

The primary design concept in a central parallel piping system is an insulated main trunk line that runs from the water heater to one or more manifolds, which then feeds use points with ½" or smaller plastic piping. The traditional central system with a single manifold must have a maximum pipe run length of 15 feet between the water heater and the manifold. With the advent of mini-manifolds, the central parallel piping system can now accommodate multiple mini-manifolds in lieu of the single central manifold, provided that a) the sum of the piping length from the water heater to all the mini-manifolds is less than 15 feet and b) all piping downstream of the mini-manifolds is nominally ½ inch or smaller.

- *Installation Criteria and Guidelines*

All applicable mandatory measures must be met. Piping between the water heater and the manifold must be insulated, and all branch piping pass the framing member from the manifold must be insulated. Piping from the manifold cannot run up to the attic and then down to points of use on the first floor. The intent of a good parallel piping design is to minimize the volume of water entrained in piping between the water heater and the end-use points, with a focus on reducing the length of the ¾-inch or 1-inch line from the water heater to the manifold(s). To encourage reducing the pipe length between the water heater and manifold, there is a distribution system compliance credit for installations that are HERS-verified to have no more than 5 feet of piping between the water heater and the manifold(s). The manifold feeds hot water use points with 3/8 or 1/2 inch PEX tubing. (Check with enforcement agencies on the use of 3/8-inch piping in the event that it is prohibited without engineering approval.) The adopted requirements for installation guidelines are included in RA3 and RA4.

5.6.2.3 Point of Use

A point-of-use distribution system design significantly reduces the volume of water between the water heater and the hot water use points. Use of this type of system requires a combination of good architectural design (that is, water heater location adjacent to hot water use points), an indoor mechanical closet, or the use of multiple water heaters. Figure 5-10 provides an example of the latter approach where three water heaters are installed close to the use points. This system is not applicable to systems serving multiple dwelling units.

- *Installation Criteria and Guidelines*

All applicable mandatory features must be met, and the distance between the water heater and any fixture using hot water cannot exceed the length specified in Table 5-10 below. The adopted requirements for installation guidelines are included in RA3 and RA4. All water heaters and hot water fixtures must be shown on plans submitted for a local building department plan check.

Figure 5-10: Point-of-Use Distribution System

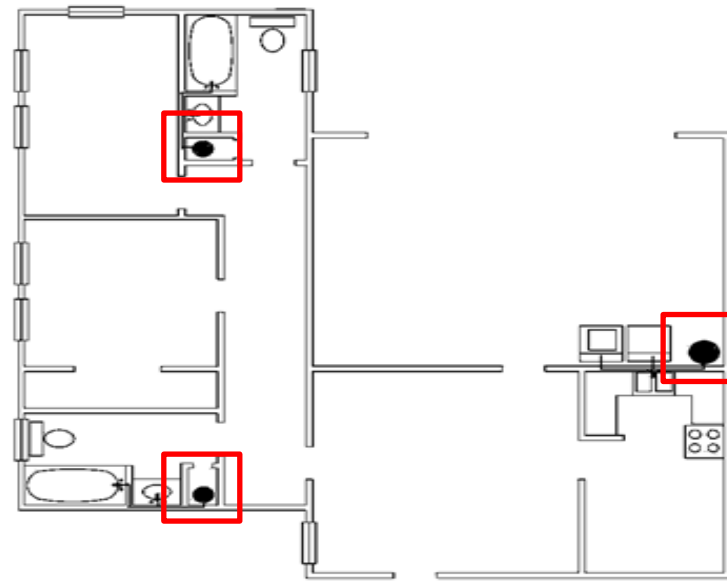

Source: 2019 CASE Initiative: Compact Hot Water Distribution

Table 5-10: Point-of-Use Distribution System

Size Nominal, Inch	Length of Pipe (feet)
3/8"	15
1/2"	10
3/4"	5

5.6.2.4 Compact Hot Water Distribution System - Basic Credit and HERS-Verified Compact Hot Water Distribution System - Expanded Credit

The intent of a compact hot water distribution system design is to reduce the size of the plumbing layout by bringing the water heater closer to hot water use points than is typical in standard homes. Through this process, energy and water will be saved, and homeowners will experience reduced hot water waiting times. This compliance option is applicable only to new single-family home and low-rise multifamily apartments where each dwelling unit is served by a dedicated water heater.

Installed hot water distribution systems are often much larger than needed in terms of excessive pipe length and oversized pipe diameter. A design consideration that often is

overlooked is the location of the water heater relative to hot water use points. Figure 5-11 below shows a common production home layout with the water heater in the corner of the garage and hot water use points in each corner of the house.

A more effective hot water distribution system design is shown in Figure 5-12. In the figure, the location of the water heater is near the kitchen, bathrooms and laundry area. The location of hot water use points plays an integral role in achieving the benefits associated with a compact distribution system design.

Eligible compact hot water distribution designs can generate a compliance credit using the performance approach. There are two versions of the Compact Design credit. Basic Credit does not require HERS verification, while Expanded Credit requires field verification by a HERS Rater. Qualification for both credits is based on using a plan view, straight-line measurement to calculate a “Weighted Distance” to key hot water use points including the master bath, kitchen, and remaining furthest hot water fixture from the water heater. (In some multifamily situations, there may not be another use point beyond the master bath and kitchen, resulting in the third term being ignored.) If this resulting Weighted Distance is less than a Qualification Distance (dependent on floor area, number of stories in the dwelling unit, and number of water heaters), then the plan is eligible for the Basic Credit. The Basic Credit does not require any further verification steps to secure the compliance credit. If the builder chooses to pursue an Expanded Credit, additional energy savings will be recognized under the performance method, however there are several HERS-verification requirements that must be met.

Figure 5-11: “Common” Production Home House Layout

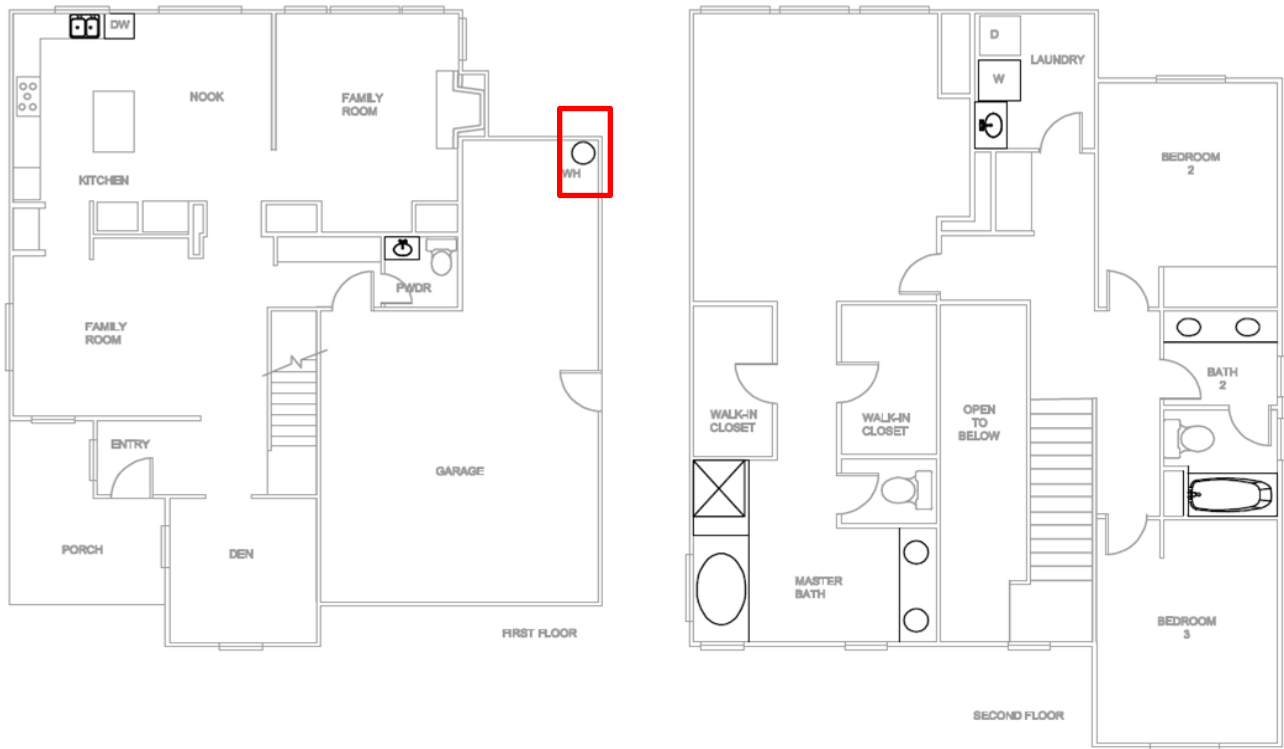

Source: 2019 CASE Initiative: Compact Hot Water Distribution

Figure 5-12: Compact Design Distribution System

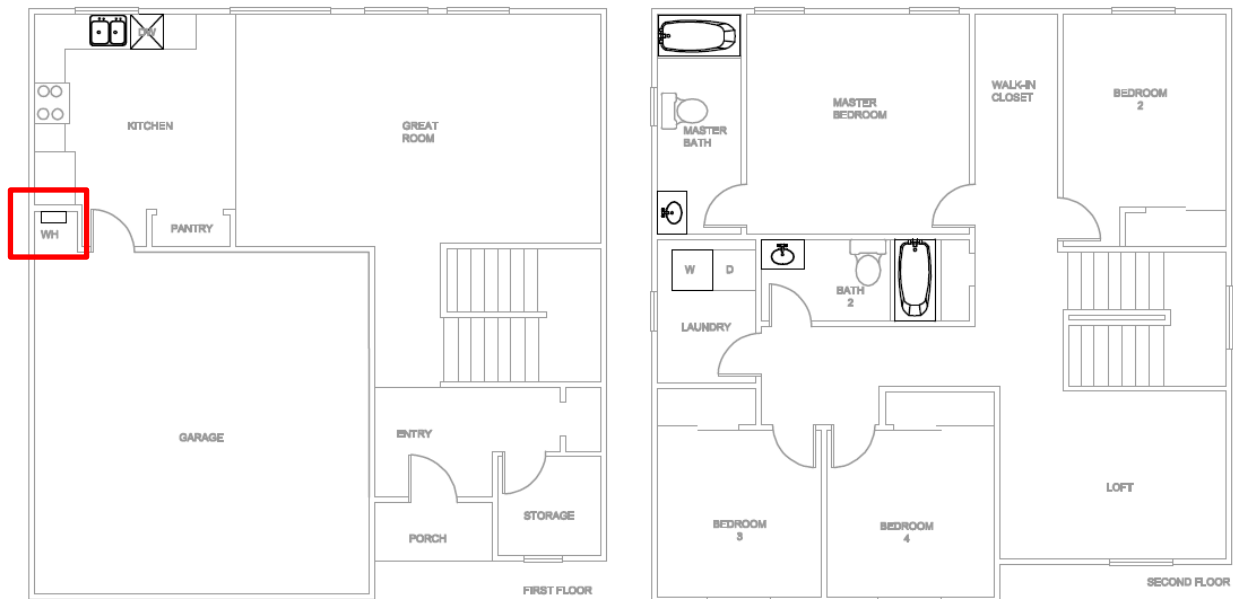

Source: 2019 CASE Initiative: Compact Hot Water Distribution

- Weighted Distance Calculation Method

Calculation of the Weighted Distance metric depends on whether it is a standard non-recirculating distribution system or a house with a recirculation distribution system.

The basis of the calculation is a plan-view, straight line measurement from the water heater to the center of the use point fixture in three rooms of the house. It is calculated using the following equation.

$$\text{Weighted_Distance} = x * d_MasterBath + y * d_Kitchen + z * d_FurthestThird$$

where,

x, y, and z = Weighted Distance coefficients (unitless), see Table 5-11.

d_MasterBath = The plan view, straight line distance from the water heater to the furthest fixture served by that water heater in the master bathroom (feet).

d_Kitchen = The plan view, straight line distance from the water heater to the furthest fixture served by that water heater in the kitchen (feet).

d_FurthestThird = The plan view, straight line distance from the water heater to the furthest fixture served by that water heater in the furthest room¹ in the house (feet).

Table 5-10 shows the values for the coefficients depending on the type of distribution system.

Table 5-11: Weighted Distance Coefficients

Distribution System	x	y	z
Non-Recirculating	0.4	0.4	0.2
Recirculating	0.0	0.0	1.0

Note that the calculations are based on horizontal plan view distance measurements from the center of the water heater to the center of the use point in the designated location. Vertical length (For example, the vertical distance from the first to second floor) is neglected in the calculations. Use points that are located on floors different than the water heater would have their location translated to the appropriate floor.

In houses with multiple water heaters, the Weighted Distance “z term” calculation is performed for each water heater to arrive at a FurthestThird term averaged over each of the “n” water heaters installed. For a non-recirculating distribution system, the resulting Weighted Distance calculation would include the Master Bath, the Kitchen and an average of the FurthestThird term for each of the installed water heaters. (For

¹ Because the master bath and kitchen represent unique defined use points, the d_FurthestThird fixture must not be located in either of these rooms. The laundry room is excluded, and should not be used as the furthest third room. In some multifamily cases, there may not be another qualifying use point, in which case the d_FurthestThird term equals zero.

recirculating systems, similarly the FurthestThird term would represent an average across the “n” water heaters.)

The calculated Weighted Distance input cell would be activated in the compliance software if the user selected either the Basic CHWDS Credit or the Expanded Credit.

Figure 5-13 shows an example weighted distance calculation for an 1,814 square foot two-story house with a standard non-recirculating distribution system. The design locates the water heater on the exterior wall, as shown by the red oval. The dotted blue lines and ovals represent translating the fixtures on the second floor to the first floor, neglecting the vertical distance. The red lines and listed distances represent the distance from the water heater to each fixture used in the calculation. The Weighted Distance calculation for this example is shown below Figure 5-13. Figure 5-14 shows a similar calculation for a centrally located water heater.

Figure 5-13: Weighted Distance Calculation for the 1,814 Plan with a Conventionally Located Water Heater

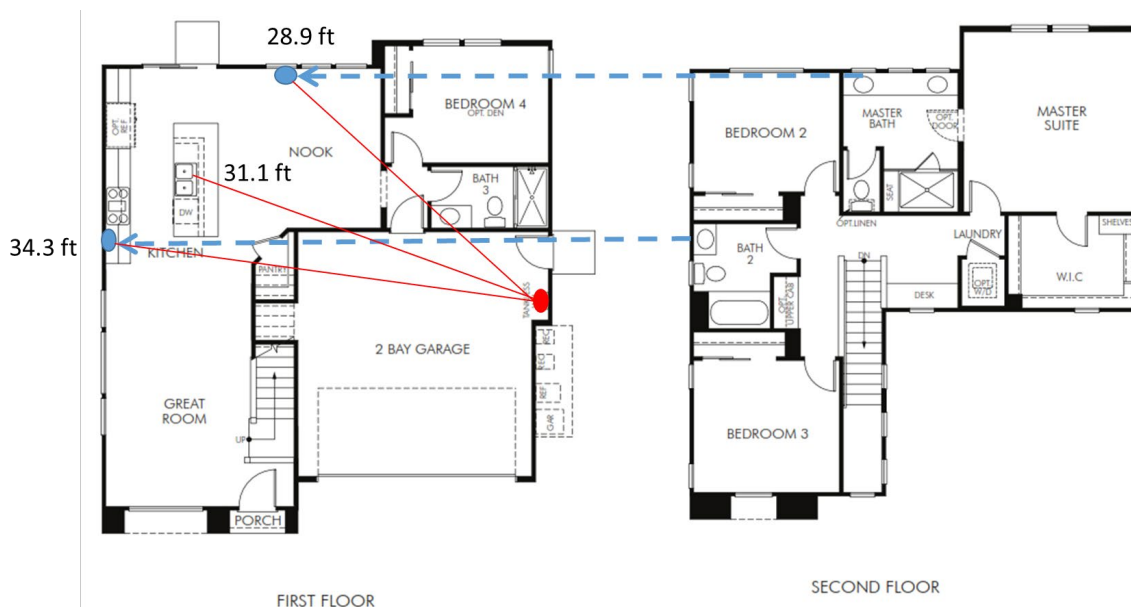

$$\text{Weighted Distance} = 0.4 * 28.9 \text{ ft} + 0.4 * 31.1 \text{ ft} + 0.2 * 34.3 \text{ ft} = 30.9 \text{ ft}$$

Source: 2019 CASE Initiative: Compact Hot Water Distribution

Figure 5-14: Weighted Distance Calculation for the 1,814 Plan with a Centrally Located Water Heater



$$\text{Weighted Distance} = 0.4 * 12.9 \text{ ft} + 0.4 * 11.8 \text{ ft} + 0.2 * 16.1 \text{ ft} = 13.1 \text{ ft}$$

Source: 2019 CASE Initiative: Compact Hot Water Distribution

5.6.2.5 Drain Water Heat Recovery System

A drain water heat recovery system recovers heat that would otherwise be lost down the drain during showers, and transfers that heat back to the water heater, shower mixing valve, or both. These systems can help users comply with the water heating requirements in the Energy Standards using either the prescriptive or performance approach. To use these systems to comply with Energy Standards, the design and installation must be HERS-verified and meet the Reference Appendix RA4.4.21 requirements.

5.6.2.6 Recirculation System – Non-Demand Control Options

This type of distribution system encompasses all recirculation strategies that do not incorporate a demand control to minimize recirculating pump operation. Under this category, recirculation system types include uncontrolled continuous recirculation, timer control, temperature control, and time/temperature controls. The intent is to clearly distinguish between recirculation system control options that result in very little daily pump operating time (demand control strategies) and the other strategies where the pump runs either continuously, or the run time is much more uncertain. Recirculation systems are known to save water, but the energy impact can be very high in a poorly designed and/or controlled system.

Installation Criteria

All piping used to recirculate hot water must be insulated to meet the mandatory requirements. Since the standards require pipe insulation for recirculating systems, these systems are not eligible for the pipe insulation credit. For systems serving a single dwelling unit, the recirculating loop within a dwelling unit must be laid out to be within 8 feet of all hot water fixtures served by the recirculating loop. As with all recirculation systems, an intelligent loop layout (loop in-board of hot water use points) and proper insulation installation are essential in obtaining desired performance. Piping in a recirculation system cannot be run up to the attic and then down to the points of use on the first floor. The adopted requirements for installation guidelines are included in Reference Appendices RA3 and RA4.

5.6.2.7 Recirculation System – Demand Control

A *demand-control recirculation system* uses brief pump operation in response to a hot water demand “signal” to circulate hot water through the recirculation loop. The system must have a temperature sensor, typically located at the most remote point of the recirculation loop. Some water heaters have temperature sensors located within the water heater. The sensor provides input to the controller to terminate pump operation when the sensed temperature rises. Typical control options include manual push button controls or occupancy sensor controls installed at key use areas (bathrooms and kitchen). Push button control is preferred from a performance perspective, since it eliminates “false signals” for pump operation that an occupancy sensor could generate. The adopted requirements for installation guidelines are included in Reference Appendices RA3 and RA4.

Installation Criteria

All criteria listed for continuous recirculation systems apply. Piping in a recirculation system cannot be run up to the attic and then down to points of use on the first floor.

Pump start-up must be provided by a push button or occupancy sensor. Pump shutoff must be provided by a temperature sensing device that shuts off the pump when the temperature sensor detects no more than 10 degree rise above the initial temperature of water in the pipe or when the temperature reaches 102 degrees F. Moreover, the controls shall limit the maximum pump run time to five minutes or less.

For a system serving a single dwelling, push buttons and sensors must be installed in all locations with a sink, shower, or tub, with the exception of the laundry room.

Plans must include a wiring/circuit diagram for the pump and timer/temperature-sensing device and specify whether the control system is manual (push button or flow switch) or other control means, such as an occupancy sensor.

5.6.3 Systems Serving Multiple Dwelling Units

5.6.3.1 Multiple Dwelling Units: Central Demand Recirculation System (Standard Distribution System)

The standard distribution system for water heaters serving multiple dwelling units incorporates recirculation loops, which bring hot water to different parts of the building, and a demand control, which automatically shuts off the recirculation pump when the recirculation flow is not needed. In summary, central recirculation systems include three components, recirculation loops, branch pipes, and pipes within dwelling units. Recirculation loops are used to bring hot water close to all dwelling units but are not expected to go through each dwelling unit. Branch pipes are used to connect pipes within dwelling units and the recirculation loops. This concept is illustrated in Figure 5-15. Designs of distribution systems within dwelling units are similar to those serving single dwelling units, described in Section 5.6.2.

Figure 5-15: Standard Multifamily Central Distribution System

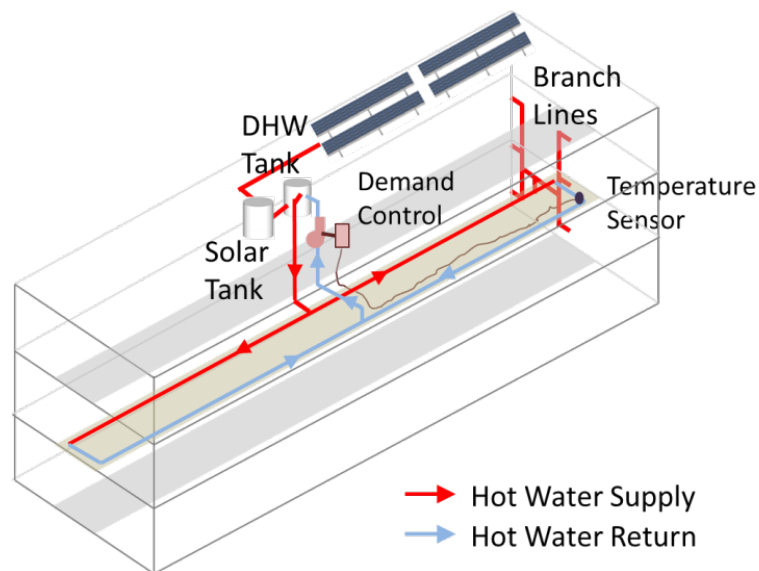

Source: 2013 CASE Initiative: Multifamily Central DHW and Solar Water Heating

Demand controls for central recirculation systems are automatic control systems that control the recirculation pump operation based on measurement of hot water demand and hot water return temperatures.

5.6.3.2 Multiple Dwelling Units: Recirculation Temperature Modulation Control

A recirculation temperature modulation control shall reduce the hot water supply temperature when hot water demand is determined to be low by the control system. The control system may use a fixed control schedule or a dynamic control schedule based on measurements of hot water demand. The daily hot water supply temperature reduction, which is defined as the sum of temperature reduction by the control in each hour within a 24-hour period, shall be more than 50 degrees Fahrenheit to qualify for the energy savings credit.

Recirculation systems shall also meet the requirements of Section 110.3.

5.6.3.3 Multiple Dwelling Units: Recirculation Continuous Monitoring Systems

Systems that qualify as recirculation continuous monitoring systems for domestic hot water systems serving multiple dwelling units shall record no less frequently than hourly measurements of key system operation parameters, including hot water supply temperatures, hot water return temperatures, and status of gas valve relays for water-heating equipment. The continuous monitoring system shall automatically alert building operators of abnormalities identified from monitoring results.

Recirculation systems shall also meet the requirements of Section 110.3.

5.6.3.4 Non-recirculating Water Heater System

Multifamily buildings may also use systems without a recirculation system, if the served dwelling units are closely located so that the branch pipes between the water-heating equipment and dwelling units are relatively short. Long branch lines will lead to excessive energy and water waste.

5.7 Combined Hydronic System

5.7.1 Combined Hydronic

Combined hydronic space heating systems use a single heat source to provide space heating and domestic hot water. The current modeling of these system types is fairly simplistic, treating water heating performance separately from the space-heating function.

5.8 Showerheads

5.8.1 Certification of Showerheads and Faucets

Maximum flow rates have historically been set by the *Appliance Efficiency Regulations*, and all faucets and showerheads sold in California must meet these standards. California's *Title 20 Appliance Efficiency Regulations* contain the maximum flow rate for showerheads and lavatory and kitchen faucets. Current flow requirements contained in the Title 24 Part 11 CALGreen Code set more efficiency levels. Installations of showerheads and faucets are mandatory under the CALGreen Code.

5.9 Solar Water Heating

The water heating calculation method allows water heating credits for solar water heaters. Solar thermal systems save energy by using renewable resources to offset the use of conventional energy sources.

For single-dwelling solar thermal systems, systems must be Solar Rating and Certification Corporation (SRCC) or IAPMO R&T approved. Accepted testing procedures include either a fully approved system with OG-300 test results or a built up system that uses the collector (OG-100) rating. For multifamily buildings, only systems with OG-100 collectors can be installed. For detailed instructions on installation of solar water heaters, refer to Reference Appendix RA4.4.21.

The database of SRCC-certified equipment is on the SRCC website at the following link:

http://www.solar-rating.org/certification_listing_directory/index.html

The database of IAPMO R&T-certified equipment is on the IAPMO R&T website at the following link:

<http://www.iapmort.org/Pages/SolarCertification.aspx>

Figure 5-16 summarizes the process flow for demonstrating compliance via the prescriptive and performance approaches for solar thermal systems.

Figure 5-16: Compliance Process for Solar Thermal System

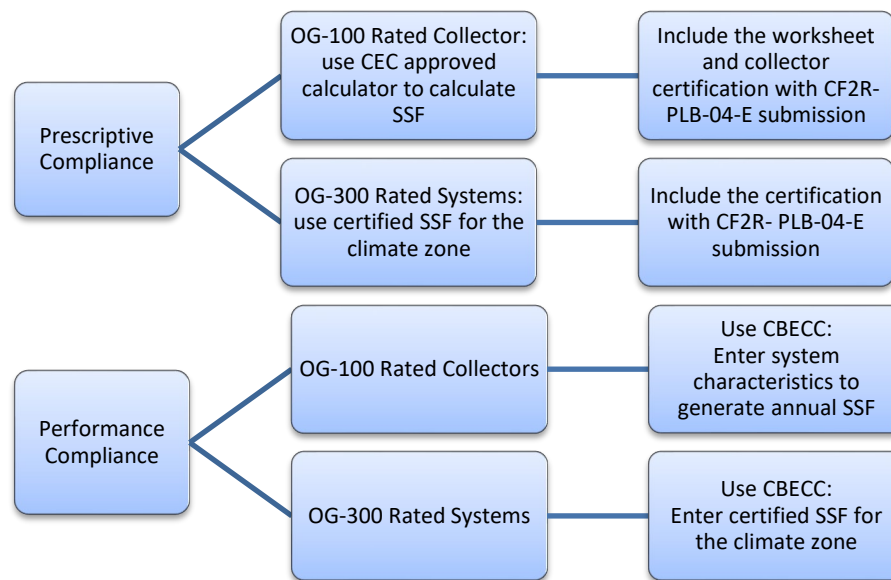

Regardless of the system type installed and compliance method chosen, mandatory requirements for pipe insulation apply as described in Section 5.3.5.1.

5.9.1 Solar or Recovered Energy in State Buildings

§110.3(c)6

Low-rise residential buildings constructed by the State of California shall have solar water heating systems. The solar system shall be sized and designed to provide at least 60 percent of the energy needed for service water heating from site solar energy or recovered energy. There is an exception when buildings for which the Division of the State Architect determines that service water heating is economically or physically infeasible. See the Compliance Options section below for more information about solar water heating systems.

5.9.1.1 Solar-Ready Buildings Requirements

§150.0(r) §110.1

There are mandatory requirements for all buildings to be “solar ready.” The motivation behind having solar-ready requirements is to encourage future installations of photovoltaic and solar water-heating systems, even if these systems are not installed during the time of new construction. Details on these solar ready requirements are in Chapter 7 – “Solar Ready Requirements” of this compliance manual. In summary, the elements to being solar-ready include:

1. A designated solar zone.
2. Designated conduit and plumbing paths.
3. Documentation for solar zone and paths on construction plans.
4. Adequate electric busbar and panel capacity.

5.9.2 Prescriptive Requirements for Solar Water Heating

This section discusses when solar water heating is required prescriptively for systems serving multiple-dwelling units.

5.9.2.1 Multifamily, Motel/Hotels, and High-Rise Nonresidential

§150.1(c)8Ciii

Solar water heating is prescriptively required for water heating systems serving multiple dwelling units, whether they are multifamily, motel/hotels, or high-rise nonresidential buildings. The minimum solar fraction depends on the climate zone (CZ):. . For multifamily buildings only, it also depends on whether compliant DWHR is installed. See Tables 5-12 and 5-13 below. The drain water heat recovery system shall be field verified as specified in the Reference Appendix RA3.6.9 and shall be compliant with the eligibility criteria in RA4.4.21.

Table 5-12: Required Performance of Solar Systems Installed in Motel/Hotels and High-Rise Nonresidential Buildings With Central Distribution Systems

<i>Climate Zone</i>	<i>Minimum Solar Fraction</i>
1-9	0.20
10-16	0.35

Table 5-13: Required Performance of Solar Systems Installed in Multifamily Buildings With Central Distribution Systems

<i>Climate Zone</i>	<i>Minimum Solar Fraction if no DWHR</i>	<i>Minimum Solar Fraction if Compliant DWHR Installed</i>
1-9	0.20	0.15
10-16	0.35	0.30

The regulations do not limit the solar water heating equipment or system type as long as they are SRCC-certified and meet the orientation, tilt, and shading requirement specified in Reference Appendix RA4.4. Installation of a solar water heating system exempts multifamily buildings from needing to set aside solar zone for future solar PV and solar water heating installation as specified in §110.10(b)1B. The following paragraphs offer some high-level design considerations for multifamily building solar water heating systems.

A high-priority factor for solar water heating system design is component sizing. Proper sizing of the solar collectors and solar tank ensures that the system takes full advantage of the sun's energy while avoiding the problem of overheating. While the issue of freeze protection has been widely explored (development of various solar water heating system types is a reflection of this evolution), the issue of overheating is often not considered as serious as it should be, especially for climate conditions with relatively high solar insolation level such as California. This is especially critical for multifamily-sized systems, due to load variability.

The solar water heating sizing requirements for the standards are conservative. For example, the highest solar fraction requirement in the *2013 Energy Standards* was at 50 percent. Stakeholders further suggested that industry standard sizing for an active system is 1.5 square feet of collector area per gallon capacity of the solar storage tank. For more detailed guidance and best practices, there are many publicly available industry design guidelines. Two such resources developed by/in association with government agencies are:

1. *Building America Best Practices Series: Solar Thermal and Photovoltaic Systems*
http://apps1.eere.energy.gov/buildings/publications/pdfs/building_america/41085.pdf.
2. *California Solar Initiative – Thermal: Program Handbook*
http://www.cpuc.ca.gov/NR/rdonlyres/CB11B92E-DFFF-477B-BFA9-F1F04906F9F9/0/CSIThermal_Handbook201209.pdf.

Because of the solar water heating requirements and the prevalence of recirculation hot water systems in multifamily buildings, it is essential to emphasize the importance of proper integration between the hot water recirculation system and the solar water heating system. Industry stakeholders recommended the recirculation hot water return to be connected back to the system *downstream* of the solar storage tank. This eliminates the unnecessary wasted energy used to heat up water routed back from the recirculation loop that may have been sitting in the solar water tank if no draw has occurred over a prolonged period.

Another design consideration is the layout and placement of collectors and solar tank. The idea here, similar to the discussions on recirculation system design in Section 5.6, is to minimize the length of plumbing, thus reducing pipe surface areas susceptible to heat loss and piping materials needed. This calls for the shortest feasible distance between the collectors themselves; furthermore, since solar tanks are typically plumbed in series just upstream of the conventional/auxiliary water heating equipment, the distance between collectors and solar tank should also be as short as possible.

5.9.3 Performance Approach Compliance for Solar Water Heating

Solar water heating systems with a solar fraction higher than the specified prescriptive minimum can be used as a tradeoff under the performance approach. Figure 5-14 shows the compliance process needed for demonstrating compliance with solar water heating modeling. The CBECC-Res API integrates the capability of calculating an annual solar fraction. Users now input collector and system component specifications to calculate a corresponding solar fraction for the proposed system.

5.10 Swimming Pool and Spa Heating

5.10.1 Swimming Pool and Spa Types

The Energy Standards include many additional requirements for residential swimming pool filtration equipment, which affect pump selection and flow rate, piping and fittings, and filter selection. These standards are designed to reduce the energy used to filter and maintain the clarity and sanitation of pool water.

5.10.2 Mandatory Requirements for Pools and Spas

Before any pool or spa heating system or equipment may be installed, the manufacturer must certify to the Energy Commission that the system or equipment complies with §110.4 and §110.5. The requirements include minimum heating efficiency according to the *Appliance Efficiency Regulations*, an on-off switch outside the heater, permanent and weatherproof operating instructions, no continuous pilot light, and no electric resistance heating. (See exceptions below.)

§110.5

Pool and spa heaters may not have continuously burning pilot lights.

§110.4

Outdoor pools and spas with gas or electric heaters shall have a cover installed. The cover should be fitted and installed during the final inspection.

There are two exceptions for electric heaters, which may be installed for:

1. Listed package units with fully insulated enclosures (for example, hot tubs), and with tight-fitting covers, insulated to at least R-6.
2. Pools or spas getting 60 percent or more of the annual heating from site solar energy or recovered energy.

5.10.2.1 Pool Pump Requirements

For maximum energy efficiency, pool filtration should be operated at the lowest possible flow rate for a period that provides sufficient water turnover for clarity and sanitation. Auxiliary pool loads that require high flow rates, such as spas, pool cleaners, and water features, should be operated separately from the filtration to allow the filtration flow rate to be kept to a minimum.

§150.0(p)1

All pumps and pump motors shall comply with the specifications of the *Appliance Efficiency Regulations*.

The pool filtration flow rate may not be greater than the rate needed to turn over the pool water volume in 6 hours or 36 gallon per minute (gpm), whichever is greater. This means that for pools of less than 13,000 gallons, the pump must be sized to have a flow rate of less than 36 gpm, and for pools of greater than 13,000 gallons, the pump must be sized using the following equation:

$$\text{Max Flow Rate (gpm)} = \frac{\text{Pool Volume (gallons)}}{360\text{min.}}$$

These are maximum flow rates. Lower flow rates and longer filtration times are encouraged and will result in added energy savings.

Pools with auxiliary pool loads must use either a multispeed pump or a separate pump for each auxiliary pool load. For example, if a spa shares the pool filtration system, either a multispeed pump must be used or a separate pump must be provided to operate the spa. If the pool system can be served by one pump of less than 1 total horsepower (hp) in capacity, the pump may be single-speed.

Filtration pump motors with a capacity of 1 hp or more must be multispeed.

All pool pumps sold in California must be tested and listed with the Energy Commission according to the *Appliance Efficiency Regulations*. Pump manufacturers must list flow rate, power, and energy factor at each of three system curves. (See Figure 5-17.) For pools equal to or less than 17,000 gallons, a pump must be chosen such that the flow rate listed for Curve A is less than the 6-hour turnover rate. For pools greater than 17,000 gallons, a pump must be chosen such that the listed flow rate at Curve C is less than the 6-hour turnover rate.

Figure 5-17: System Test Curves

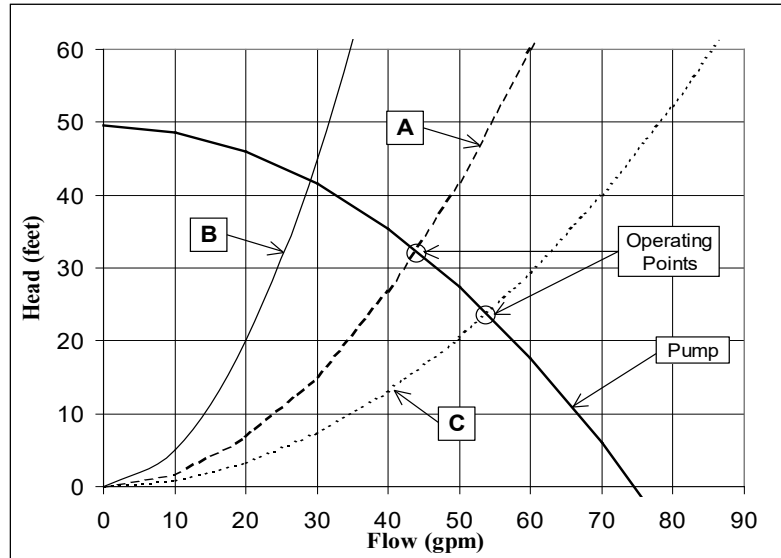

5.10.2.2 Pool Pump Controls

Pool controls are a critical element of energy efficient pool design. Modern pool controls allow for auxiliary loads such as cleaning systems, solar heating, and temporary water features without compromising energy savings.

§110.4(b)

A time switch or similar control mechanism must be installed as part of the pool water circulation control system that will allow all pumps to be set or programmed to run only during the off-peak electric demand period and for the minimum time necessary to maintain the water in the condition required by applicable public health standards.

§150.0 (p)1

Multispeed pumps must have controls that default to the filtration flow rate when no auxiliary pool loads are operating. The controls must also default to the filtration flow rate setting within 24 hours and must have a temporary override capability for servicing.

5.10.2.3 Pool Pipe, Filter, and Valve Requirements

Correct sizing of piping, filters, and valves reduces overall system head, reduces noise and wear, and increases energy efficiency. Other mandatory requirements include leading straight pipe into the pump, directional inlets for mixing, and piping to allow for future solar installations.

§110.4(b) and §150(p)2

Pool piping must be sized according to the maximum flow rate needed for all auxiliary loads. The maximum velocity allowed is 8 feet per second (fps) in the return line and 6 fps in the suction line. Table 5-14 shows the minimum pipe sizes required by pool volume based on a 6-hour turnover filtration flow rate. These pipe sizes would need to be increased if there are auxiliary loads that operate at greater than the filtration flow

rate. Conversely, they could be reduced if the pump is sized for greater than a 6-hour turnover filtration flow rate.

Table 5-14: Hour Turnover Pipe Sizing

<i>Pool Volume (gallons)</i>		<i>Minimum Pipe Diameter (in)</i>	
Min	Max	Return	Suction
-	13,000	1.5	1.5
13,000	17,000	1.5	2.0
17,000	21,000	2.0	2.0
21,000	30,000	2.0	2.5
30,000	42,000	2.5	3.0
42,000	48,000	3.0	3.0
48,000	65,000	3.0	3.5

There must be a length of straight pipe that is greater than or equal to at least 4 times the pipe diameters installed before the pump. That is, for a 2-inch suction pump, there must be at least 8 inches of straight pipe before the pump strainer basket.

Traditional hard 90° elbows are not allowed. All elbows must be sweep elbows or a type of elbow that has a pressure drop less than the pressure drop of straight pipe with a length of 30 times the pipe diameters. For example, a 2-inch elbow must have a pressure drop less than a 5-foot length of a 2-inch straight pipe.

Field verification of sweep elbows may be performed by checking that the distance “w” of the installed sweep elbow is greater than that for a hard 90 elbow. (Refer to Figure 5-16.) The difference in measurement between the radial edge of one sleeve to the perpendicular side of the elbow is found to be distinct between sweep elbows and hard 90s. There is sufficient difference in distance “w” such that all sweep elbows exceed the minimum values listed in Table 5-15.

Figure 5-18 below illustrates “w” the dimension between the elbow sleeves, and Table 5-14 shows the minimum distances “w” for an acceptable sweep elbow.

Figure 5-18: Measuring “W” at the Pool Site

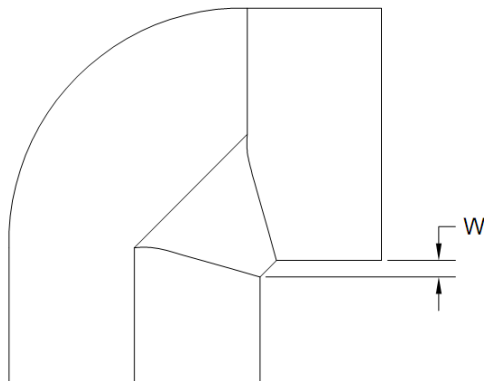

Table 5-15: Pool Site Measurement for Sweep Elbows

<i>Pipe Diameter</i>	<i>Minimum W (inch)</i>
1.5	3/8
2	1/2
2.5	5/8
3	3/4
4	1

Filters shall be sized using NSF/ANSI 50 based on the maximum flow rate through the filter. The filter factors that must be used are in ft²/gpm:

- a. Cartridge 0.375
- b. Sand 15
- c. Diatomaceous Earth 2

Backwash valves must be sized to the diameter of the return pipe or 2 inches, whichever is greater. Multiport backwash valves have a high-pressure drop and are discouraged. Low-loss slide and multiple three-way valves can provide significant savings.

The pool must have directional inlets to adequately mix the pool water.

If a pool does not use solar water heating, piping must be installed to accommodate any future installation. Contractors can choose one of three options to allow for the future addition of solar heating equipment:

1. Provide at least 36 inches of pipe between the filter and the heater to allow for the future addition of solar heating equipment.
2. Plumb separate suction and return lines to the pool dedicated to future solar heating.
3. Install built-up or built-in connections for future piping to solar water heating. An example of this would be a capped off tee fitting.

Example 5-12 – Pool Covers

Question:

My pool has both a solar heater and a gas heater. Do I need to install a pool cover?

Answer:

Yes. A cover is required for all pools with gas or electric heaters, regardless of whether they also have a solar heater.

Example 5-13 – Pool Pump

Question:

I have a 25,000 gallon pool and want to use a two-speed pump with a Curve C flow rate of 79 gpm on high-speed and 39 gpm on low-speed. Is this okay, and what size piping must I installed?

Answer:

The maximum filtration flow rate for a 25,000-gallon pool is 69 gpm by using equation [Max Flow Rate (gpm) =Pool Volume (gallons) / 360 minutes], so the pump is adequately sized, as long as a control is installed to operate the pump on low-speed for filtration. The maximum pipe size must be based on the maximum flow rate of 79 gpm. Referencing Table 5-9, you must use 2.5-inch suction and 2-inch return piping.

5.11 Compliance and Enforcement

Chapter 2 of this compliance manual addresses the compliance and enforcement process generally and discusses the roles and responsibilities of each of the major parties, the compliance forms, and the process for field verification and/or diagnostic testing. This section highlights compliance enforcement issues for water heating systems.

5.11.1 Design Review

The design review verifies that the certificate of compliance matches the plans and specifications for the proposed building. The certificate of compliance has a section where special features are listed. The following are water heating features that should be listed in this section of the certificate of compliance:

1. Any system type other than one water heater per dwelling unit
2. Non-NAECA large water heater performance
3. Indirect water heater performance
4. Instantaneous gas water heater performance
5. Distribution system type and controls
6. Solar system
7. Combined hydronic system

If any of these measures are called out on the certificate of compliance, special attention should be given to make sure that identical information is located on the plan set. Highlighting key concerns or adding notes will allow field inspectors to quickly catch any measures that should be installed that made a significant difference in compliance.

5.11.2 Field Inspection

During construction, the contractor or the specialty contractors or both complete the necessary sections of the certificate of installation. For water heating, there is only one section to be completed where information about the installed water heating system is entered if complying prescriptively with the installation of a gas instantaneous, gas storage above 55 gallons, or a NEEA Tier-3 rated heat pump water heater. Additional

documents will be needed to comply prescriptively for all other options. (See Appendix A.)

Inspectors should check that the number and types of water heating systems indicated on the installation certificates match the approved certificate of compliance. The distribution system is also significant and must correspond to plan specifications.

5.11.3 HERS Field Verification and/or Diagnostic Testing

5.11.3.1 Single Family and Multifamily With Individual Dwelling Water Heaters

HERS verification is required for all hot water distribution types that include options for field verification. The first type is alternative designs to conventional distribution systems that include parallel piping, demand recirculation, and automatic and manual on-demand recirculation. The second type is for compact distribution systems earning the expanded credit, which can be used only when verified by field verification. For all of the cases where HERS verification is required, the HERS Rater must verify that the eligibility requirements in RA3.6 for the specific system are met.

In addition, HERS-verified drain water heat recovery is an option for prescriptive compliance and as a compliance credit for the performance approach.

As previously described in this chapter, if a user wishes to comply prescriptively with the Energy Standards and installs a minimally compliant gas storage water heater (55 gallons or less), then either the compact distribution design (expanded credit) or a compliant drain water heat recovery system must be installed, both of which require HERS verification.

5.11.3.2 Multifamily With Central Water Heating Systems

The HERS verification for water heating that applies to central domestic hot water recirculation systems in multifamily buildings is the verification of multiple distribution lines for central recirculation systems, and the verification of drain water heat recovery systems.

5.12 Glossary/Reference

5.12.1 General Glossary/Reference for Water Heating

Relevant terms are defined in Reference Joint Appendix JA1.

The following are terms that are either not defined in JA1 or expansions to the Appendix I definitions.

- A. **External tank insulation** can be applied to the exterior of storage type water heater tanks. When installed, water heater insulation should be applied to completely cover the exterior of the water heater, but should not conceal controls or access ports to burners, obstruct combustion air openings, or interfere in any way with safe water heater operation. Insulation of top and bottom surfaces is not necessary.

- B. **Recovery energy** is the energy used to heat water.
- C. **Recovery load** is the load on the water heater due to hot water end uses and distribution losses.
- D. **Single dwelling unit** is a residence with a dedicated water heater. Single dwelling units can be a single-family home or an individual dwelling unit in a multifamily building, as long as each unit has a dedicated water heater.
- E. **Thermal efficiency** is defined in the *Appliance Efficiency Regulations* as a measure of the percentage of heat from the combustion of gas or oil that is transferred to the hot water as determined using the applicable test methods.
- F. **Uniform energy factor (UEF)** of water heater is the uniform energy descriptor used to describe the overall water heater efficiency as determined using the applicable test method in the *Appliance Efficiency Regulations*. Typical gas storage water heaters have typical UEFs of about 0.60-0.76, electric storage water heaters approximately 0.90, and gas instantaneous units approximately 0.80-0.94. It replaced the “energy factor” metric previously used for residential water heaters.

5.12.2 General Glossary/Reference for Swimming Pool and Spa

- A. **Flow rate** is the volume of water flowing through the filtration system in a given time, usually measured in gallons per minute.
- B. **Nameplate power** is the motor horsepower (hp) listed on the nameplate and the horsepower by which a pump is typically sold.
- C. **Pool pumps** usually come with a leaf strainer before the impeller. The pumps contain an impeller to accelerate the water through the housing. The motors for residential pumps are included in the pump purchase but can be replaced separately. The pumps increase the “head” and “flow” of the water. Head is necessary to move fluid through pipes, drains, and inlets, push water through filters and heaters, and project it through fountains and jets. Flow is the movement of the water used to maintain efficient filtering, heating, and sanitation for the pool.
- D. **Return** refers to the water in the filtration system returning to the pool. The return lines or return side, relative to the pump, can also be defined as the pressure lines or the pressure side of the pump. Water in the returns is delivered back to the pool at the pool inlets.
- E. **Service factor**. The service factor rating indicates the percentage above nameplate horsepower at which a pump motor may operate continuously when full-rated voltage is applied and ambient temperature does not exceed the motor rating. Full-rated pool motor service factors can be as high as 1.65. A 1.5 hp pump with a 1.65 service factor produces 2.475 hp (total hp) at the maximum service factor point.
- F. **Suction** created by the pump is how the pool water gets from the skimmers and drains to the filtration system. The suction side and suction lines refer to the vacuum side of the pump. It is at negative atmospheric pressure relative to the pool surface.

- G. **Total dynamic head (TDH)** refers to the sum of all the friction losses and pressure drops in the filtration system from the pools drains and skimmers to the returns. It is a measure of the system's total pressure drop and is given in units of either psi or feet of water column (sometimes referred to as "feet" or "feet of head").
- H. **Total motor power** or T-hp, refers to the product of the nameplate power and the service factor of a motor used on a pool pump.
- I. **Turnover** is the act of filtering one volume of the pool.
- J. **Turnover time** (also called *turnover rate*) is the time required to circulate the entire volume of water in the pool or spa through the filter. For example, a turnover time of 6 hours means an entire volume of water equal to that of the pool will be passed through a filter system in six hours.

Turnover Time = Volume of the pool

Flow rate

Table of Contents

6.	Residential Lighting	1
6.1	Overview	1
6.1.1	What's New for the 2019 California Energy Code	1
6.1.2	Scope	2
6.1.3	Residential Functional Areas in Nonresidential Buildings	2
6.1.4	Related Resources	3
6.2	Indoor Luminaire Requirements	3
6.2.1	Residential Luminaires – High Efficacy by Default	4
6.2.2	Residential Luminaires – JA-8 Compliant	5
6.2.3	Recessed Downlight Luminaires in Ceilings	6
6.2.4	Recessed Luminaires other than Ceiling-Recessed Downlight Luminaires	8
6.2.5	Enclosed Luminaires	8
6.2.6	Screw-Based Luminaires	9
6.2.7	Night Lights, Step Lights and Path Lights	9
6.2.8	Light Sources in Drawers, Cabinets, and Linen Closets	9
6.2.9	Blank Electrical Boxes	11
6.3	Indoor Lighting Control Requirements	12
6.3.1	Lighting Control Requirements in Accordance with Room and Luminaire Types	12
6.3.2	Lighting Control Functionality	14
6.4	Interior Common Area Lighting Requirements for Multifamily Residential Buildings	16
6.4.1	Low-Rise Multifamily – Common Area Lighting Requirements	16
6.4.2	High-Rise Multifamily – Common Area Lighting Requirements	18
6.5	Residential Outdoor Lighting Requirements	19
6.5.1	Outdoor Luminaires	19
6.5.2	Single-Family Outdoor Lighting	19
6.5.3	Low-Rise Residential Buildings and Other Applications – Outdoor Lighting	20
6.5.4	High-Rise Residential Buildings – Outdoor Lighting	21
6.5.5	Internally Illuminated Signs	21

6.6	Residential Garage, Parking Lot and Carport Lighting	22
6.6.1	Single-Family – Garage Lighting	23
6.6.2	Low-Rise Residential - Parking Lot and Carport Lighting	23
6.6.3	High-Rise Residential - Parking Lot and Carport Lighting	23
6.7	Additions and Alterations	24
6.8	Compliance Documentation	24
6.8.1	Certificate of Installation (CF2R-LTG)	24
6.9	For Homeowners.....	26
6.9.1	Lighting Schedule Submitted to Homeowner.....	26
6.10	For Building Officials	26
6.10.1	Plans.....	26
6.10.2	Compliance Documentation.....	27
6.10.3	Inspections	28
6.11	For Manufacturers – Certification to the Energy Commission	31
6.11.1	Luminaires and Lamps and Other Light Sources Complying with JA8 and JA10	32
6.11.2	Lamps and Luminaires Associated with ENERGY STAR® Programs.....	32
6.11.3	Marking Designation and Product Data Required for Certified JA8 Luminaires, Lamps and Light Sources.....	33

6. Residential Lighting

This chapter covers Title 24 California Code of Regulations, Part 6 (California Energy Code, or the Energy Standards), requirements for lighting in low-rise residential buildings and the dwelling units in high-rise residential buildings. It is for lighting designers, electrical engineers, and enforcement agency staff working on residential lighting.

6.1 Overview

For residential buildings and spaces, all the lighting requirements are mandatory. The residential lighting requirements are different from the nonresidential ones because there are no maximum lighting power threshold for spaces, no required calculation of lighting power, and no prescriptive method for showing compliance. There are luminaire requirements and lighting control requirements for residential lighting installations.

The residential luminaire requirements apply to permanently installed luminaires, including luminaires with easily interchangeable lamps. They do not apply to portable luminaires such as table lamps or freestanding floor lamps. The lighting control requirements are focused on dimming and occupancy sensing control requirements for applicable spaces and occupancies.

All section (§) and table references in this chapter refer to sections and tables contained in Title 24 California Code of Regulations, Part 6, also known as California Energy Code or the Energy Standards.

6.1.1 What's New for the 2019 California Energy Code

- Clarification edits to the language of the residential lighting requirements in order to improve consistency such as the luminaire efficacy requirement of Section 150.0(k)1 and the different luminaires listed in Table 150.0-A as meeting the efficacy requirement.
- Minor modifications to the lighting controls requirements to maintain consistency with the requirements for dimmers and vacancy sensors.
- Edits to the language of the residential outdoor lighting requirements in order to improve readability, such as eliminating the redundant requirement of override to ON.
- Clarification edits to Table 150.0-A; eliminated outdated references to GU-24 socket; streamlined references to LED light sources and solid state lighting.
- Testing requirements for testing laboratories and manufacturers by harmonizing the requirements of Reference Joint Appendix JA8 with similar tests under the ENERGY STAR® program for lamps and luminaires.

- Clarification changes to the JA8 requirement including requirements about sample size, efficacy test, start time test, and color characteristics test.
- Clarification of the definition of habitable space in §100.1 to include or exclude spaces. A habitable space includes spaces designed for living, sleeping, eating, or cooking, and excludes bathrooms, toilets, hallways, storage areas, closets, and utility rooms.

6.1.2 Scope

The residential lighting requirements in the Energy Standards apply to more than just single-family homes. Space types covered include:

- Single-family buildings, indoor and outdoor lighting.
- Low-rise multifamily buildings (three stories or less), indoor and outdoor lighting. Refer to Section 6.4.1 for low-rise multifamily requirements.
- High-rise multifamily residential units.
Refer to Section 6.4.2 for high-rise multifamily requirements.
- Outdoor lighting, additions and alterations.
Refer to Section 6.5 for outdoor residential lighting requirements.
Refer to Section 6.7 for additions and alterations of residential buildings.
- Residential spaces in nonresidential buildings.
The following subsections list the spaces required to comply.

6.1.3 Residential Functional Areas in Nonresidential Buildings

The following areas in nonresidential, high-rise residential, and hotel/motel buildings are required to comply with the low-rise residential lighting standards, as defined in §130.0(b):

- High-rise residential dwelling units
- Outdoor lighting attached to a high-rise residential building or hotel/motel and separately controlled from inside of a dwelling unit or guest room
- Fire station dwelling accommodations
- Hotel and motel guest rooms. Guest rooms are also required to comply with the lighting shut-off requirements in §130.1(c)8, which require captive card key controls, occupant sensing controls, or automatic controls. Guest rooms must also meet the controlled receptacle requirements of §130.5(d)4)
- Dormitory and senior housing dwelling accommodations. The requirements also apply to additions and alterations to functional areas of existing buildings specified above.

- All other function areas in nonresidential, high-rise residential, and hotel/motel buildings, such as common areas, shall comply with the applicable nonresidential lighting standards.

6.1.4 Related Resources

The California Energy Commission and others prepare educational resources with information about residential lighting. The Energy Commission's resources are here: http://www.energy.ca.gov/efficiency/educational_resources.html.

6.2 Indoor Luminaire Requirements

A luminaire, which is a light fixture, is defined by §100.1 as a complete lighting unit consisting of a light source such as a lamp or lamps and the parts that distribute the light, position and protect the light source and connect it to the power supply.

A lamp is a light bulb or similar separable lighting component. It is defined by §100.1 as an electrical appliance that produces optical radiation for visual illumination with a base to provide an electrical connection between the lamp and a luminaire, and installed into a luminaire. The definition is expanded to clarify that a lamp is not a luminaire and is not an LED retrofit kit designed to replace additional components of a luminaire.

The 2019 Energy Standards for residential lighting require all permanently installed luminaires to be high efficacy, as specified in §150.0(k). Permanently installed lighting is defined in §100.1 and examples of permanently installed lighting include:

- Lighting attached to walls, ceilings, or columns.
- Track and flexible lighting systems.
- Lighting inside permanently installed cabinets.
- Lighting attached to the top or bottom of permanently installed cabinets.
- Lighting attached to ceiling fans.
- Lighting integral to exhaust fans.
- Lighting integral to garage door openers if it is used as general lighting, is switched independently from the garage door opener, and does not automatically turn off after a pre-determined amount of time.

The following are examples of non-permanently installed lighting:

- Portable lighting as defined by §100.1 (including, but not limited to, table and freestanding floor lamps with plug-in connections);
- Lighting installed by the manufacturer in refrigerators, stoves, microwave ovens, exhaust hoods for cooking equipment, refrigerated cases, vending machines, food preparation equipment, and scientific and industrial equipment;

- Lighting in garage door openers which consists of no more than two screw-based sockets integrated into the garage door opener by the manufacturer, where the lights automatically turn on when the garage door is activated, and automatically turn off after a pre-determined amount of time.

6.2.1 Residential Luminaires – High Efficacy by Default

Luminaires in any of the following categories are automatically classified as high efficacy and do not have to comply with the requirements of Reference Joint Appendix JA8 (aka JA8 – refer to next section for details).

- a. Pin-based linear fluorescent luminaires using electronic ballasts.
- b. Pin-based compact fluorescent luminaires using electronic ballasts
- c. Pulse-start metal halide luminaires.
- d. High pressure sodium luminaires.
- e. Luminaires with induction lamp and hardwired high frequency generator.
- f. LED luminaires installed outdoors.
- g. Inseparable solid state lighting (SSL) luminaires containing colored light sources for decorative lighting purpose.

Recessed downlight luminaires must meet the JA8 requirements.

Screw-based luminaire types must have a JA8-compliant light source or lamp installed in them at the time of inspection.

All other luminaire types must also meet the JA8 requirements.

Table 6-1 summarizes the requirements for residential high-efficacy luminaires. There are luminaires automatically classified as high efficacy, luminaires that must use JA8-certified light sources or lamps, and recessed downlight luminaires in ceilings.

Table 6-1 (A Short Version of Table 150.0-A): Summary of Compliant Luminaire Types

High-Efficacy Luminaires*	JA8 High-Efficacy Lighting – Lamps and Light Sources that must be JA8-certified	*Recessed Downlight Luminaires in Ceilings
<ul style="list-style-type: none"> • Pin-based linear fluorescent light sources using electronic ballasts • Pin-based compact fluorescent light sources using electronic ballasts • Pulse-start metal halide light sources • High-pressure sodium light sources • Luminaires with induction lamp and hardwired high frequency generator • LED light sources installed outdoors • Inseparable SSL luminaires containing colored light sources for decorative lighting purpose 	<ul style="list-style-type: none"> • Light sources installed in ceiling recessed downlight luminaires. The downlights shall not have screw bases. • LED luminaires with integral sources • Screw-based LED lamps (A-lamps, PAR lamps, etc.) • Pin-based LED lamps (MR-16, AR-111, etc.) • Any light source or luminaire not listed elsewhere in this table 	<ul style="list-style-type: none"> • Shall not have screw-based sockets • Shall contain JA8-certified light sources • Shall meet all performance requirements in §150.0(k)1C

6.2.2 Residential Luminaires – JA-8 Compliant

Luminaires not listed in the previous section must have an integral light source or removable lamp that meets the performance requirements of JA8. The requirements in JA8 ensure that new lighting technologies like LED provide energy-efficient light, while also maintaining performance characteristics that customers expect. In addition to setting minimum efficacy requirements, JA8 establishes performance requirements that ensure accurate color rendition, dimmability, and reduced noise and flicker during operation.

Luminaires with integral sources, such as LED luminaires, must be certified by the Energy Commission as meeting the JA8 requirements. Luminaires that have changeable lamps (such as screw-base luminaires) must be installed with lamps that have been certified by the Energy Commission.

Luminaires and lamps that the Energy Commission certified must be marked with JA8-2019 or JA8-2019-E on the product. The JA8-2019-E marking indicates that the product

has passed the more stringent ENERGY STAR's Elevated Temperature Life test as specified in Reference Joint Appendix JA8 of Section JA8.3.5. The product is appropriate for elevated temperature applications for installation such as in enclosed luminaires.

Luminaires that can be classified as high efficacy by meeting the requirements of JA8 include:

1. LED luminaires with integral light sources that are certified to the Energy Commission.
2. Screw-based luminaires with JA8-certified lamps.
3. Low-voltage pin-based luminaires with JA8-certified lamps.

Almost any luminaire can be classified as high efficacy, as long as the luminaire is installed with a JA8 compliant lamp. The exception is recessed downlight luminaires in ceilings, which must meet additional requirements.

The Energy Commission maintains a database of certified JA8-compliant luminaires, lamps, and light sources. The database can be accessed using a Quick Search Tool (<https://cacertappliances.energy.ca.gov/Pages/ApplianceSearch.aspx>) or an Advanced Search (<https://cacertappliances.energy.ca.gov/Pages/Search/AdvancedSearch.aspx>).

6.2.3 Recessed Downlight Luminaires in Ceilings

In addition to the high-efficacy requirements, there are several additional requirements for residential downlight luminaires that are recessed in ceilings.

Figure 6-1 Recessed Downlight Luminaires in Ceiling



Source: © 2018 Lutron Electronics Co., Inc. All rights reserved.

The first set of requirements limit the light sources and lamp types used in recessed downlight luminaires. Recessed downlights:

1. Shall contain light sources that are JA8-certified.
2. Shall not contain screw-based lamps.
3. Shall not contain light sources that are labeled not for use in enclosed fixtures or not for use in recessed fixtures.

All recessed downlight luminaires must contain a light source or lamp that is JA8-certified, such as an integral LED source or LED lamp. Screw-based lamps such as LED A-lamps or LED PAR lamps are not allowed. Pin-based lamps such as LED MR-16 lamps are allowed in recessed fixtures as long as they are JA8-certified.

In addition to the light source and lamp requirements listed, recessed downlight luminaires in ceilings must also meet all the following performance requirements:

1. Be listed for zero clearance insulation contact (IC) by Underwriters Laboratories or another nationally recognized testing/rating laboratory;
2. Have a label that certifies the luminaire is airtight with air leakage less than 2.0 cubic feet per minute (CFM) at 75 Pascals when tested in accordance with ASTM E283 (exhaust fan housings are not required to be airtight);
3. Be sealed with a gasket or caulk between the luminaire housing and ceiling, and have all air leak paths between conditioned and unconditioned spaces sealed with a gasket or caulk;
4. For luminaires with hardwired ballasts or drivers, allow ballast or driver maintenance and replacement to be readily accessible to building occupants from below the ceiling without requiring holes to be cut in the ceiling.

Luminaires that meet the first two performance criteria will list this information on luminaire cut sheets or packaging. Contractors are responsible to ensure that luminaires are properly sealed, and any ballasts or drivers are accessible.

Recessed downlight luminaires that do not meet all requirements cannot be used for residential lighting.

**Figure 6-2 Recessed Luminaire with an IC Housing (left);
Recessed Luminaire with a Non-IC Housing (right)**



Source: © 2018 Lutron Electronics Co., Inc. All rights reserved.

6.2.4 Recessed Luminaires other than Ceiling-Recessed Downlight Luminaires

For recessed luminaires to be installed in new residential spaces, the installed light sources and lamps shall be JA8-compliant to meet the elevated temperature requirement. The JA8-compliant lamps and light sources shall have the JA8-2019-E marking to signify that it can be installed in an enclosed luminaire.

6.2.5 Enclosed Luminaires

Any enclosed luminaire to be installed in residential spaces shall be used with JA8 compliant lamps or light sources meeting the elevated temperature requirement. The JA8-compliant lamps and light sources shall have the JA8-2019-E marking to signify that it can be installed in an enclosed luminaire.

The certified JA8-compliant lamps and light sources can be looked at in the Energy Commission's Appliance Database by going to <https://cacertappliances.energy.ca.gov/Pages/ApplianceSearch.aspx>.

Figure 6-3 Images of JA8-2019-E Compliant Lamps



Source: Maxlite

6.2.6 Screw-Based Luminaires

For screw-based luminaires to be installed in residential spaces, the installed lamps shall be JA8-compliant lamps.

6.2.7 Night Lights, Step Lights and Path Lights

Night lights, step lights and path lights can be installed by complying with the residential lighting requirement of the Energy Code by either:

1. The luminaire complies with Table 150.0-A (A short version of the table is at page 6-4);
2. The luminaire is controlled by a vacancy sensor as required under Section 150.0(k)2I in applicable spaces (bathrooms, garages, laundry rooms and utility rooms). It is rated no more than 5 watts (W) of power and emits no more than 150 lumens.

6.2.8 Light Sources in Drawers, Cabinets, and Linen Closets

Light sources in drawers, cabinets, and linen closets can be installed by complying with the residential lighting requirement of the Energy Code by either:

1. The luminaire complies with Table 150.0-A (A short version of the table is at page 6-4) ;
2. The luminaire is controlled to be automatically off when the drawer, cabinet or linen closet is closed, and is also controlled by a vacancy sensor as required under Section 150.0(k)2I in applicable spaces (bathrooms, garages, laundry rooms and utility rooms). The luminaire is rated no more than 5W of power and emits no more than 150 lumens.

Example 6-1: Screw-based luminaires

Question

I am using a screw-based luminaire that is rated to take a 60W lamp for lighting over a sink, and I plan to install a 10W LED lamp. Does it meet the residential lighting requirement for screw-based luminaire and Table 150.0-A?

Answer

If the LED lamp is JA8-certified and marked JA8-2019 or JA8-2019-E, then it meets the residential lighting requirement on screw-based luminaire and Table 150.0-A.

Example 6-2: Color-tunable and dim-to-warm luminaires installed in residential buildings

Question

Can color-tunable luminaires and dim-to-warm luminaires be certified to meet JA8 specifications?

Answer

The JA8 specifications require the color temperature (correlated color temperature, CCT) of the light sources to be no greater than 4000 Kelvin (K). If the color-tunable

luminaire product or the dim-to-warm luminaire product produces a color temperature of no greater than 4000K, it meets the color temperature criteria of JA8.

Example 6-3: Fade-in lighting

Question

I would like to use lighting with an aesthetic fade-in feature in my design. The JA8 has a start time requirement. Are fade-in lights able to qualify as high efficacy?

Answer

Aesthetic fade-in lights are acceptable under Title 24. The test procedure for start time measures “[t]he time between the application of power to the device and the point where the light output reaches 98% of the lamp’s initial plateau.” The “initial plateau” is “[t]he points at which the average increase in the light output over time levels out (reduces in slope).”

For light sources with a fade-in feature, the light output intentionally follows a programmed fade-in curve to increase light output gradually. Because the light output must level out, the initial plateau for these light sources is the point in time at which there is perceived light output and the perceived light increase begins to follow the programmed fade-in curve. The programmed fade-in curve is expected to be continuously increasing as a function of time.

This allows fade-in lighting to qualify as high efficacy.

Example 6-4: Kitchens exhaust hood lighting

Question

I am installing an exhaust hood over my kitchen range that has lamps in it. Do these lamps have to be high efficacy?

Answer

This lighting is part of an appliance and does not have to meet the residential lighting requirements for permanently installed lighting.

Example 6-5: Kitchen alterations

Question

I am designing a residential kitchen lighting system with six 12W LED recessed downlights and four 24W LED tape lights for under cabinet lighting. How many watts of incandescent or halogen luminaires can be installed?

Answer

None. Low efficacy luminaires are no longer allowed for residential lighting. All luminaires must meet the definitions of high-efficacy luminaires in Table 150.0-A of the Energy Standards.

Example 6-6: Night lights**Question**

Where are night lights permitted to be installed in residential buildings?

Answer

There are no location restrictions in the Energy Standards. Permanently installed night lights and night lights integral to installed luminaires can be installed anywhere in single family buildings, dwelling units of multifamily buildings, or other residential spaces.

6.2.9 Blank Electrical Boxes

For blank electrical boxes mounted more than 5 feet above the finished floor, the boxes shall be served by a dimmer, vacancy sensor, or fan speed control.

Example 6-7: Blank electrical boxes**Question**

How many blank electrical boxes located more than 5 feet above the finished floor can be installed in a residential building or space?

Answer

The number of boxes can be as many as the number of bedrooms in a residential building or dwelling unit. The number of boxes can be less but not more than the number of bedrooms.

This requirement applies to those located more than 5 feet above the finished floor. It does not apply to boxes mounted below 5 feet or at 5 feet above the floor.

6.3 Indoor Lighting Control Requirements

Using lighting controls is an important part of the Energy Standards because they can produce energy savings for the owners and users of the spaces.

6.3.1 Lighting Control Requirements in Accordance with Room and Luminaire Types

Following are general control requirements that apply for the room type and for the luminaire type:

A. Readily Accessible Manual Controls

All permanently installed luminaires shall have readily accessible wall-mounted controls that permit the luminaires to be manually turned on and off.

B. Multiple Switches

This applies to three-way, four-way, and other lighting circuits controlled by more than one switch. A lighting circuit controlled by more than one switch where a dimmer or vacancy sensor has been installed to comply with §150.0(k) shall meet all the following conditions:

1. No controls shall bypass the dimmer or vacancy sensor function.
2. The dimmer or vacancy sensor must comply with the applicable requirements of §110.9(b).

C. Energy Management Control Systems (EMCS) and MultiScene Programmable Controllers

An EMCS system with the appropriate lighting control functionality can be installed for meeting the lighting control requirements of Section 110.9 and 150.0(k)2.

A multiscene programmable controller with the appropriate dimmer functionality can be installed for meeting the dimmer requirements of Section 110.9 and the applicable requirements of Section 150.0(k)2.

The EMCS or the multiscene programmable controller do not have to be certified to the Commission. However, the person who is constructing and installing the EMCS system must complete an installation certificate.

D. Exhaust Fans

There are two options for the lighting associated with the fans:

1. All lighting shall be controlled separately from exhaust fans.
2. For an exhaust fan with an integral lighting system, it must be possible for the lighting system to be manually turned on and off while allowing the fan to continue operating for an extended period of time.

E. Ceiling Fans

Ceiling fans with integrated light sources can be controlled with a remote control.

F. Spaces Required to Have Vacancy Sensors / Occupancy Sensors

The following residential spaces are required to have at least one luminaire in the space to be controlled by an occupancy or vacancy sensor:

1. Bathrooms
2. Garages
3. Laundry Rooms
4. Utility Rooms

G. Luminaires Required to Have Dimmers or Vacancy/Occupancy Sensors

All LED luminaires are required to be controlled by a National Electrical Manufacturers Association (NEMA) SSL-7A-compliant dimmer unless they are controlled by a vacancy sensor or an occupancy sensor. The combined use of NEMA SSL-7A-compliant dimmer with LED luminaires can ensure flicker free operation when the luminaire is dimmed. This dimmer/light source compatibility information is on dimmer cut sheets or dimmer product packaging.

For the 2019 Standards, occupancy sensors can be installed for meeting the vacancy sensor requirement of the residential lighting standard as long as the occupancy sensor operates in the manual-ON and automatic-OFF mode.

Dimmers and vacancy sensors are not required for any luminaires located in hallways or in closets less than 70 square feet.

Example 6-8: Using vacancy sensors and dimmers

Question

Can I install vacancy sensors in hallways and closets even though the Energy Code does not require it?

Answer

Installing controls such as vacancy sensors in hallways and closets is allowed.

A vacancy sensor turns off lighting when a space is unoccupied. This can save energy and the energy bill compared to a manual on-off switch control where the light may be left on for some unattended periods.

Using vacancy sensors is recommended for any application where they can provide additional energy savings or additional amenity for the homeowner or occupant.

A dimmer varies the intensity of the light to suit the occasions or the time of the day. When less light is needed, the homeowner can reduce the light intensity with a dimmer and save energy.

6.3.2 Lighting Control Functionality

All installed lighting controls listed in §110.9(b) shall comply with the requirements listed below. In addition, all components of the system installed together shall meet all applicable requirements for the application for which they are installed as required in §130.0 through §130.5, §140.6 through §140.8, §141.0, and §150.0(k).

Designers and installers should review features of their specified lighting control products for meeting the requirements of Section 110.9(b) as part of the code compliance process.

A. Time-Switch Lighting Controls

Time-switch lighting control products shall provide the functionality listed in Section 110.9(b)1 of the Energy Code.

B. Dimmer

Dimmer products shall provide the functionality listed in Section 110.9(b)3 of the Energy Code.

There is also a compatibility requirement for forward phase cut dimmers used with LED light and the dimmers must comply with NEMA SSL 7A, as mentioned earlier in this manual.

C. Occupant Sensing Controls

Occupant sensing control products (including occupant sensors, partial-ON occupant sensors, partial-OFF occupant sensors, motion sensors, and vacancy sensor controls) shall provide the functionality listed in Section 110.9(b)4 of the Energy Code.

One important functionality is automatically turning the lights either off or down within 20 minutes after the area has been vacated.

Exception to the requirement: Occupant sensing control systems may consist of a combination of single or multi-level occupant, motion, or vacancy sensor controls, provided that components installed to comply with manual-on requirements shall not be capable of conversion by occupants from manual-on to automatic-on functionality.

D. Using Vacancy Sensors or Occupancy Sensors

Manual-on/automatic-off occupant sensors, also known as vacancy sensors, automatically turn lights off if an occupant forgets to turn them off when a room is unoccupied.

Additionally, the sensors are required to provide the occupant with the ability to manually turn the lights:

1. Off upon leaving the room
2. Off while still occupying a room
3. On upon entering the room

The manual-off feature provides the occupants with the flexibility to control the lighting environment and to turn off the lights when they are not needed.

The 2019 Standards allow occupancy sensors to be installed to meet the vacancy sensor requirement of the residential lighting standard as long as the occupancy sensor is configured to operate in the manual-ON and automatic-OFF mode.

Example 6-9: Bathroom vacancy sensors--manual off**Question**

Should the vacancy sensor in a bathroom provide the occupant the option of turning the light off manually?

Answer

The vacancy sensor must provide the occupant with the option to turn the lights off manually.

If an occupant forgets to turn the lights off when a room is unoccupied, then the vacancy sensor must turn the lights off automatically within 20 minutes. The occupant must also have the ability to turn the lights off upon leaving the room.

Occupants have the flexibility to control the lighting environment and products greater energy savings since the lights can be turned off when they are not needed.

Example 6-10: Use of automatic-on occupancy sensors**Question**

What are the options to use an automatic-on occupant sensor in a bathroom, garage, laundry room, or utility room?

Answer

Automatic-on occupant sensors that can be configured to manual-on operation can be installed to meet the residential lighting control requirements for bathrooms, garages, laundry rooms, and utility rooms.

Example 6-11: Using Energy Management Control System (EMCS) for controls**Question**

What EMCS are permitted in the controls for under cabinet lighting?

Answer

An EMCS can be used to control under cabinet lighting provided that the under cabinet lighting is switched separately from ceiling lighting systems as specified in §150.0(k)2K.

6.4 Interior Common Area Lighting Requirements for Multifamily Residential Buildings

There are different applicable lighting requirements for low-rise residential buildings and high-rise residential buildings. Buildings are defined as low-rise and high-rise buildings according to the following.

A low-rise residential building is a building, other than a hotel/motel, in one of the following occupancy groups:

- R-2, multifamily, with three habitable stories or less;
- R-3, single-family; or
- U-building, located on a residential site.

A high-rise residential building is a building, other than a hotel/motel, of occupancy group R-2 or R-4 with four or more habitable stories.

Interior common areas in multifamily buildings include areas such as interior hallways, lobbies, entertainment rooms, pool houses, club houses, and laundry facilities. Lighting requirements for these spaces depend on the characteristics of the buildings. Low-rise buildings are those three stories or less, and while high-rise buildings are four stories or higher.

6.4.1 Low-Rise Multifamily – Common Area Lighting Requirements

The residential lighting requirements apply to lighting within dwelling units in multifamily buildings. In addition to the residential lighting requirements, if the interior common area of a low-rise multifamily building is greater than 20 percent of the total floor area, the lighting in the common areas must comply with the nonresidential lighting standards.

Lighting requirements in common areas of low-rise multifamily buildings depend on the percentage of the total interior common area in each building. Buildings in which the interior common area equals 20 percent or less to the floor area have one set of requirements. Buildings whose total interior common area is greater than 20 percent of the total floor area have different requirements.

A. If The Common Area Equals 20 Percent or Less of The Total Building Floor Area

In low-rise multifamily buildings where the total interior common area in a single building is 20 percent or less of the total floor area, all permanently installed lighting in interior common areas must comply with Table 150.0-A and be controlled by occupancy sensors.

B. If The Common Area is Greater Than 20 Percent of The Total Building Floor Area

In low-rise multifamily buildings where the total interior common area in a single building is greater than 20 percent of the total floor area, permanently installed lighting in common areas must meet the applicable nonresidential lighting control

and power requirements. Corridor and stairwell lighting must be controlled by occupant sensors.

The relevant nonresidential lighting requirements that apply are:

1. §110.9 – Mandatory Requirement for Lighting Controls
2. §130.0 – Lighting Systems and Equipment, and Electrical Power Distribution Systems – General
3. §130.1 – Mandatory Indoor Lighting Controls
4. §140.6 – Prescriptive Requirements for Indoor Lighting
5. §141.0 – Additions, Alterations, and Repairs to Existing Nonresidential, High-Rise Residential, and Hotel/Motel Buildings, to Existing Outdoor Lighting, and to Internally and Externally Illuminated Signs

These sections cover allowable equipment, controls requirements for various space types, allowable lighting power densities for various space types, and requirements for additions and alterations to existing buildings. More information about the nonresidential lighting requirements that apply is in Chapter 5 of the Nonresidential Compliance Manual.

In addition to meeting the applicable nonresidential lighting requirements, lighting in corridors and stairwells in these buildings must meet the following occupancy control requirements:

1. Occupancy controls must reduce stairway and corridor lighting power by at least 50 percent when the spaces are unoccupied.
2. Occupancy controls must be capable of turning stairwell and corridor lighting fully on and off from all designated paths of ingress and egress.

Example 6-12: Multifamily common areas: low rise

Question

Does the lighting for an interior common-area hallway of a low-rise residential building with a total common area of 10 percent of the total building area have to comply with the residential or nonresidential lighting requirements?

Answer

The lighting of an interior common-area hallway of any low-rise residential building with total common area of 20 percent or less of the total building area must comply with only the residential lighting requirements.

Example 6-13: Egress lighting for common areas in low-rise multifamily buildings

Question

What is the egress lighting requirement for interior common areas in low-rise multifamily buildings?

Answer

The only Energy Standards requirement is that all luminaires must be high efficacy. Refer to California Code of Regulations, Title 24, Part 2, Chapter 10, for emergency egress lighting requirements.

6.4.2 High-Rise Multifamily – Common Area Lighting Requirements

Lighting within residential units in high-rise multifamily or high-rise residential buildings is required to comply with the residential lighting requirements. Common areas in all high-rise multifamily buildings must meet all applicable nonresidential lighting requirements. In addition, any outdoor lighting attached to a high-rise residential building controlled from within a residential unit must meet the residential lighting requirements.

Common areas in all high-rise multifamily buildings (four stories or greater) must meet all applicable nonresidential lighting requirements in the following sections:

1. §110.9 – Mandatory Requirement for Lighting Controls.
2. §130.0 – Lighting Systems and Equipment, and Electrical Power Distribution Systems – General.
3. §130.1 – Mandatory Indoor Lighting Controls.
4. §130.4 – Lighting Control Acceptance and Installation Certificate Requirements.
5. §140.6 – Prescriptive Requirements for Indoor Lighting.
6. §141.0 – Additions, Alterations, and Repairs to Existing Nonresidential, High-Rise Residential, and Hotel/Motel Buildings, to Existing Outdoor Lighting, and to Internally and Externally Illuminated Signs.

These sections cover allowable equipment, controls requirements for various space types, allowable lighting power densities for various space types, and requirements for additions and alterations to existing buildings. More information about the nonresidential lighting requirements that apply can be found in Chapter 5 of the Nonresidential Compliance Manual.

Dwelling units within high-rise multifamily buildings must comply with the residential lighting requirements.

Example 6-14: Multifamily common areas: high rise

Question

Does the lighting for an interior common-area hallway of a high rise residential building have to comply with the residential or nonresidential lighting requirements?

Answer

The lighting of an interior common-area hallway of a high-rise residential building must comply with the nonresidential lighting standards. All the lighting in common areas must comply with the nonresidential standards. Lighting inside the dwelling units must comply with the residential lighting requirements.

Hallways and stairwells are required to have partial off occupancy sensors that switch off at least half the lighting load when the hallway or stairwell is unoccupied.

6.5 Residential Outdoor Lighting Requirements

Outdoor residential lighting is sometimes subject to the residential lighting requirements, and sometimes subject to the nonresidential lighting requirements.

6.5.1 Outdoor Luminaires

All lighting attached to the residence or to other buildings on the same lot must be high efficacy. Table 150.0-A lists all qualifying high-efficacy light sources. Outdoor LED luminaires and LED light sources installed outdoors are automatically classified as high efficacy and are not required to comply with JA8.

6.5.2 Single-Family Outdoor Lighting

All lighting attached to the residence or to other buildings on the same lot must be high efficacy, and must be controlled by a manual ON and OFF switch and one of the following automatic control types:

1. Photocontrol and either a motion sensor or an automatic time switch control;
or
2. Astronomical time clock control.

Any override to the above automatic controls to ON must return to automatic control operations within six hours.

Lighting not permanently attached to a building on a single-family site, such as decorative landscape lighting, is not regulated by the residential lighting requirements. High efficacy lighting and controls such as a time clock or photocontrol will help save energy and ensures that the lighting is not accidentally left on during daylight hours.

Table 6-2: Outdoor Lighting Standards for Single Family Buildings

Outdoor Lighting Requirements (Res is short for Residential Standards; Nonres is short for Nonresidential Standards)	
Spaces or Areas with Outdoor Lighting	Single Family Buildings
Outdoor lighting mounted to building	Res
Private patios, entrances, balconies, and porches	Res

6.5.3 Low-Rise Residential Buildings and Other Applications – Outdoor Lighting

Low-rise residential buildings with four or more dwelling units and the following applications have the option of complying with either the residential or nonresidential lighting standards.

1. Private patios
2. Entrances
3. Balconies
4. Porches

For all other outdoor lighting applications, low-rise buildings with four or more dwelling units must comply with the nonresidential lighting requirements.

Table 6-3: Outdoor Lighting Standards for Low-Rise Residential Buildings

Outdoor Lighting Requirements (Res is short for Residential Standards; Nonres is short for Nonresidential Standards)		
Spaces or Areas with Outdoor Lighting	Low-Rise Residential Buildings	
	1-3 Dwelling Units	4 or more Dwelling Units
Private patios, entrances, balconies, and porches	Res or Nonres (builder's option)	Res or Nonres (builder's option)
Outdoor lighting not regulated by Section 3B	Res or Nonres	Nonres

Example 6-15: Outdoor lighting controls for hotel guestrooms:

Question

What are the requirements for exterior lighting of a hotel guestroom, such as balcony light?

Answer

Section 150.0(k)3B applies to “outdoor lighting for private patios, balconies, and porches.” Either residential lighting controls or nonresidential lighting controls can be selected for meeting Title 2.4.

6.5.4 High-Rise Residential Buildings – Outdoor Lighting

Any outdoor lighting attached to the building, which is controlled from within the dwelling unit, must comply with the residential requirements.

Outdoor lighting attached to the building that is not controlled from within the dwelling unit must comply with the following nonresidential requirements:

1. §110.9 – Mandatory Requirement for Lighting Controls
2. §130.0 – Lighting Systems and Equipment, and Electrical Power Distribution Systems – General
3. §130.2 – Outdoor Lighting Controls and Equipment
4. §130.4 – Lighting Control Acceptance and Installation Certificate Requirements
5. §140.7 – Requirements for Outdoor Lighting
6. §141.0 – Additions, Alterations, and Repairs to Existing Nonresidential, High-Rise Residential, and Hotel/Motel Buildings, to Existing Outdoor Lighting, and to Internally and Externally Illuminated Signs

More on the nonresidential lighting requirements is Chapter 5 of the Nonresidential Compliance Manual.

6.5.5 Internally Illuminated Signs

Internally illuminated signs shall consume no more than 5W of power, or shall comply with the nonresidential sign lighting requirements in §140.8.

Example 6-16: Outdoor lighting: glare control

Question

Are there cutoff requirements for residential outdoor luminaires?

Answer

There are no cutoff requirements for typical residential outdoor lighting. Residential parking lots for eight or more vehicles are required to meet the nonresidential standards, which do include cutoff requirements for luminaires with initial lumens greater than 6,200 lumens. The requirement uses the backlight, uplight and glare (BUG) ratings developed by the IES to define acceptable amounts of uplight and glare (there are no limits on “backlight.”) Even though not required for most residential outdoor lighting, luminaires that limit uplight are usually more efficient at providing light in the required area, so a lower wattage lamp and ballast can be used. The BUG requirements also reduce stray light and glare problems which can cause visual discomfort.

Example 6-17: Outdoor lighting: landscape lighting

Question

I would like to install low-voltage landscape lighting in my yard. Are these required to be on a motion sensor and photocontrol?

Answer

No. Although the lighting requirements only apply to lighting that is attached to the building, it is advisable to use photocontrols or astronomical time clock controls for landscape lighting so that the lighting is not left on during daylight hours.

Example 6-18: Outdoor lighting: patios

Question

Does outdoor lighting on the patio of a high-rise residential building have to comply with the residential or nonresidential lighting standards?

Answer

If the patio outdoor lighting is controlled from inside of the dwelling unit, it must comply with the residential outdoor lighting standards. If the patio outdoor lighting is controlled from outside of the dwelling unit, it must comply with the nonresidential outdoor lighting standards. For example, if the outdoor patio lighting is controlled by a building-wide EMCS outside of the dwelling units, it must comply with the nonresidential outdoor lighting standards.

6.6 Residential Garage, Parking Lot and Carport Lighting

Residential garages are treated as indoor spaces, while residential parking lots and carports are treated as outdoor spaces. These parking facilities are required to meet either the residential or the nonresidential requirements, depending on what type of building they are associated with.

All lighting attached to the residence or to other buildings on the same lot must be high efficacy. See Table 150.0-A for qualifying high efficacy light sources. Outdoor LED luminaires and LED light sources installed outdoors are automatically classified as high efficacy.

Regardless of the classification of the associated building, residential garages for 8 vehicles or more must comply with all applicable nonresidential indoor lighting requirements in §110.9, §130.1, §130.4, §140.6 and §141.0.

See Nonresidential Compliance Manual Chapter 5 for the nonresidential indoor lighting requirements, and Chapter 6 for the nonresidential outdoor lighting requirements.

Low-rise residential garages for less than 8 vehicles have to comply with requirements of §150.0(k)2l - the lighting to be controlled by occupant or vacancy sensors.

6.6.1 Single-Family – Garage Lighting

Garages on single-family sites with space for 7 vehicles or less must comply with the residential lighting control requirements in §150.0(k)2I, which require at least one luminaire in each garage to be controlled by an occupant or vacancy sensor.

Garages for 8 vehicles or more must comply with the applicable nonresidential indoor lighting requirements.

6.6.2 Low-Rise Residential - Parking Lot and Carport Lighting

For low-rise residential buildings, the associated parking lots and carports with less than 8 vehicles per site must comply with either the applicable nonresidential outdoor lighting requirements or the residential requirements shown on the following table.

Table 6-4: Residential Lighting Control Requirements of Section 150.0(k)3A

Residential Outdoor Lighting Control Requirements	
All lighting must be controlled by a manual ON and OFF switch	Mandatory
Photocontrol and either a motion sensor or an automatic time switch control	Choose one
Astronomical time clock control	

For low-rise residential parking lots and carports with more than 8 vehicles per site, they must comply with the applicable nonresidential outdoor lighting requirements.

6.6.3 High-Rise Residential - Parking Lot and Carport Lighting

Parking lots and carports for high-rise residential buildings must comply with the applicable nonresidential outdoor lighting requirements.

Example 6-19: Parking spaces

Question

I have a low-rise multi-family complex with 20 parking spaces. The parking spaces are arranged throughout the site in groups of only four spaces each. Are these spaces required to comply with the nonresidential outdoor lighting requirements?

Answer

Yes, these spaces are required to comply with the nonresidential outdoor lighting standards. Parking lots and carports with 8 or more vehicles per site must meet the nonresidential outdoor lighting requirements, regardless of how the spaces are arranged.

6.7 Additions and Alterations

Additions are considered newly constructed buildings, so they must meet the applicable residential lighting requirements of §150.0(k).

For alterations, existing luminaires may stay in place but any new permanently installed luminaires shall meet the requirements of §150.0(k).

Residential building additions must meet all mandatory requirements in §150.0. Because the residential lighting requirements are mandatory, lighting in all residential building additions must meet the requirements outlined in this chapter.

For residential building alterations, any new or altered lighting systems must also meet all the requirements in this chapter. Existing luminaires and lighting systems that are not altered may stay as is. Use JA8 compliant trim kits or JA8 compliant lamps to alter existing screw-based ceiling recessed luminaires to be code-compliant.

6.8 Compliance Documentation

Submit the compliance documentation for residential lighting, which is a certificate of installation, after the lighting project is complete.

All residential lighting requirements are mandatory. There are no tradeoffs between lighting and other building features.

6.8.1 Certificate of Installation (CF2R-LTG)

Lighting control systems are required to comply with the certificate of installation (form CF2R-LTG). Although designed primarily as a nonresidential compliance document, the certificate is also required when a lighting control system is used to comply with the residential lighting requirements.

A. Person Responsible to Submit the Certificate of Installation

The person responsible for constructing and installing the residential lighting project (Title 24 California Code of Regulations, Part 1, §10-103(a)3.) must submit the certificate. The individual must be eligible under Division 3 of the Business and Professions Code. The person should ensure the installed lighting complied with the applicable lighting requirements before signing the certificate.

B. Number of Certificates of Installation Required

A residential lighting project may require more than one certificate to be submitted. If one qualified person accepts responsibility for the lighting installation of an entire lighting project, one certificate is needed. If one qualified person installs the lighting controls and another installs the luminaires, then each individual will need to submit a separate certificate.

A certificate must be submitted to the responsible code enforcement agency for any residential lighting project that is regulated by Part 6, whether that project is one luminaire or lighting the entire building.

The contractor installing hard-wired lighting systems must complete and sign the certificate. The installer verifies compliance with the mandatory requirements for lighting and whether high-efficacy lighting and the required controls (i.e., vacancy sensors, dimmer switches) were installed.

C. Registration

Registration is required for newly constructed low-rise residential buildings and for an addition or alteration project for which compliance requires Home Energy Rating System (HERS) field verification (see Title 20 California Code of Regulations §1670 et seq.). When registration is required, the certificates must be submitted electronically to an approved HERS provider data registry for registration and retention.

Registration requirements are in Chapter 2 of the *2019 Residential Compliance Manual*.

D. Certificate of Installation Requirements in the Standards

The following is the Energy Standards' language that requires the certificate to be submitted when a lighting control system is installed to comply with any residential lighting control requirements.

1. §150(k)2F – Lighting controls must comply with the applicable requirements of §110.9.
2. §110.9(a) – Lighting control devices and systems must meet the lighting control installation requirements in §130.4.
3. §130.4(b) – Lighting Control Installation Certificate Requirements
To be recognized for compliance with Part 6, an Installation Certificate shall be submitted in accordance with §10-103(a) for any lighting control system and Energy Management Control System (EMCS) in accordance with the following requirements, as applicable:
 - a. Certification that when a lighting control system is installed to comply with the lighting control requirements in Part 6, it complies with the applicable requirements of §110.9 and complies with Reference Nonresidential Appendix NA7.7.
 - b. Certification that when an EMCS is installed to function as a lighting control required by Part 6 it functionally meets all applicable requirements for each application for which it is installed, in accordance with §110.9, §130.0 through §130.5, §140.6, §140.7, and §150.0(k); and complies with Reference Nonresidential Appendix NA7.7.2.
4. §150(k)2G – An EMCS may be used to comply with control requirements in §150.0(k) if, at a minimum, it provides the functionality of the specified

controls in accordance with §110.9, meets the installation certificate requirements in §130.4, the EMCS requirements in §130.0(e), and complies with all other applicable requirements in §150.0(k)2.

5. §150(k)2H – A multi-scene programmable controller may be used to comply with dimmer requirements in §150.0(k) if at a minimum it provides the functionality of a dimmer in accordance with §110.9, and complies with all other applicable requirements in §150.0(k)2.

6.9 For Homeowners

6.9.1 Lighting Schedule Submitted to Homeowner

A schedule of all interior luminaires and lamps installed must be delivered to the homeowner after final inspection (Title 24 California Code of Regulations, Part 1, §10-103(b)3). In addition to a list of installed lighting systems, the schedule should include necessary system information for regular operations and maintenance, and references to support future upgrades to the lighting system.

6.10 For Building Officials

This section provides guidance for enforcement agency personnel about what to look for on the plans, what compliance documents to expect, and high-priority issues to focus on in inspections.

6.10.1 Plans

A. Confirm All Specified Luminaires Are High Efficacy

All permanently installed luminaires shown on the plans and/or specifications must be high efficacy (§150.0(k)1A). Luminaires may comply with §150.0(k)1A as follows:

1. Luminaires automatically classified as high efficacy; or
2. Luminaires that must use JA8-certified light sources or lamps; or
3. JA8-certified luminaires.

LED luminaires installed outdoors and a number of conventional types are automatically classified as high efficacy. Refer to Section 6.2 for details about high-efficacy luminaires and JA8 compliant luminaires. Compliant luminaire types are in Table 6-1.

Plans, lighting specifications, and/or notes should specify how luminaires will comply.

B. Confirm All Required Controls Are Specified

Plans and specifications should indicate vacancy or occupancy sensing controls with at least one luminaire in each of the following spaces:

1. Bathrooms
2. Laundry rooms
3. Garages
4. Utility rooms

Luminaires installed with JA8 lamps (lamps and light sources) with dimming capability are required to be controlled by a NEMA SSL-7A dimmer, vacancy sensor, or occupancy sensor.

More additional information about indoor lighting control requirements is in Section 6.3.

C. Confirm Any Applicable Outdoor and Nonresidential Lighting Standards

Outdoor lighting shall be shown on plans or described in specifications and/or notes to be high efficacy and to meet the control requirements of §150.0(k)3.

Plans, specifications, and notes should also describe any applicable nonresidential common area or outdoor lighting requirements.

6.10.2 Compliance Documentation

Confirm that all required compliance documentation is included with the plans.

A. Certificate of Installation

The certificate (CF2R-LTG) is the primary compliance documentation for residential lighting. There will be one or more CF2R-LTG forms submitted for each project. Confirm lighting systems and lighting controls in the project are covered by a CF2R-LTG. Confirm all CF2R-LTG forms are registered.

B. Lighting Schedule

Builders must submit a lighting schedule to homeowners or occupants at the time of occupancy. This schedule should describe all installed interior luminaires and lamps. A draft schedule should be included for the plan check.

C. Documentation for Control Systems

Some lighting control systems will also require specific compliance documentation.

6.10.3 Inspections

A. Confirm Luminaires Are Properly Installed

All installed luminaires should be high efficacy or JA8-compliant.

JA8-compliant luminaires, lamps, and light sources should have a factory or manufacturer's mark with JA8-2019 or JA8-2019-E.

Ceiling recessed downlight luminaires should have a JA8-2019 mark.

Lamps and light sources installed in enclosed luminaires and recessed luminaires should have a JA8-2019-E mark.

B. Confirm Lighting Controls Are Properly Installed

Lighting controls are properly installed per lighting applications for the spaces.

At least one luminaire in bathrooms, laundry rooms, garages, and utility rooms are controlled with a vacancy/occupancy sensing controls.

Dimmers or vacancy/occupancy sensing controls must control JA8 light sources with dimming capability.

C. Confirm Any Applicable Outdoor and Nonresidential Lighting Standards

All lighting attached to a single-family building or other buildings on the same lot must be high efficacy, and must be controlled by a manual ON and OFF switch and one of the following automatic control types:

1. Photocontrol and either a motion sensor or an automatic time-switch control; or
2. Astronomical time-clock control.

Low-rise residential buildings with four or more dwelling units can comply with the residential or nonresidential lighting standards for certain applications such as private patios, entrances, balconies, porches, residential parking lots, and carports with less than eight vehicles per site.

Refer to Section 6.5 for the complete outdoor lighting requirements.

Lighting that is not permanently attached to a building on a single-family site, such as landscape lighting, is not regulated by the Energy Standards.

If there is any nonresidential outdoor lighting, refer to Chapter 6 of the *2019 Nonresidential Compliance Manual* Chapter 6 for the outdoor lighting requirements.

D. Inspections for Ceiling Recessed Downlight Luminaires

Recessed downlight luminaires must be insulation contact (IC) rated and have a gasket or caulking between the housing and ceiling to prevent heated or cooled air from flowing between conditioned and unconditioned spaces.

Luminaires must include a label certifying airtight or similar designation to show air leakage less than 2.0 CFM at 75 Pascals when tested in accordance with

ASTM E283. The label must be visible for the building inspector. The building official may verify the IC and ASTM E283 labels during rough inspection. If verified at final inspection, the official may remove the trim kit to see the labels.

The ASTM E283 certification is a laboratory procedure that measures the leakage of the luminaire housing or an airtight trim kit, and not the installation. Luminaire housings labeled as airtight, airtight ready, or other airtight designation do not establish that a luminaire has been installed airtight. The luminaire manufacturer shall provide instructions about the assembly required to achieve an airtight installation.

Manufacturers use different methods to meet the airtight standards. These methods include using caulk or gaskets to reduce air leakage at the luminaire housing. The lighting requirements do not favor one airtight method over another.

Because luminaire housing is not always installed perfectly parallel to the ceiling surface, both methods have their benefits as follows:

1. Caulk will fill in and seal wide and uneven gaps. After the caulk dries, it may permanently attach the luminaire housing or trim to the ceiling surface. The caulk may need to be cut away from the ceiling surface in case that a luminaire housing or trim needs to be moved away from the ceiling.
2. Many gaskets allow the luminaire housing or trim to be moved away from the ceiling after installation. If the gasket is too thin or not made out of an air stopping material, it may not sufficiently reduce the air flow between the conditioned and unconditioned spaces. Although the standards do not specify the material needed for a gasket, an open cell type of foam, particularly if the gasket is relatively thin, will not create an airtight barrier.

Install a certified airtight luminaire so that it prevents heated or cooled air from flowing between conditioned and unconditioned spaces. Seal all air leak paths through the luminaire assembly or the ceiling opening. Leak paths in the installation assembly that are not part of the ASTM E283 testing must be sealed with either a gasket or caulk.

Verify an airtight installation by:

1. Manufacturer specifications (a "cut sheet") of the certified airtight luminaire housing(s) and installation instructions are made available with the plans to show all components of the assembly needed to ensure there is an airtight installation consistent with §150.0(k)1C. This allows the building inspector to know what the manufacturer specifies to achieve airtight installation and to determine the construction phase that the luminaire should be inspected for airtight compliance.
2. The luminaire manufacturer will specify one of the methods to ensure an airtight seal of the certified airtight housing to the ceiling:
 - a. A gasket is attached to the bottom of the certified airtight housing before installing the ceiling (i.e., drywall or other ceiling materials) to create a seal. The gasket may be preinstalled at the factory, or may need to be field installed. For field installed gaskets, instructions on how the gasket

is to be attached shall be provided by the manufacturer. The luminaire shall be installed so that the gasket will be sufficiently compressed by the ceiling when the ceiling is installed. A gasket that is too thin will not provide an airtight seal.

- b. A gasket is applied between the certified airtight housing and the ceiling opening after the ceiling has been installed. The gasket creates the seal. The cut sheet and installation instructions for the airtight conditions shall detail how to attach the gasket.
 - c. Caulk is applied between the certified airtight housing and the ceiling after the ceiling has been installed. The caulk creates the airtight seal. The cut sheet or installation instructions shall specify the type of caulk that must be used and how the caulk shall be applied.
 - d. A certified airtight trim kit is attached to the housing after the ceiling has been installed. The kit in combination with the luminaire housing makes the manufactured luminaire airtight. A decorative luminaire trim that is not ASTM E283-certified does not make the manufactured luminaire airtight. Most decorative luminaire trims are not designed to make a luminaire airtight. These trims are used to provide a finished look between the ceiling and luminaire housing, and may include a reflector, baffle, and/or lens. Some trim kits are designed to make a luminaire installation airtight. These kits shall be certified airtight in accordance with ASTM E283. Certified kits consist of a one-piece lamp-holder, reflector cone, and baffle. The cut sheet and installation instructions for the airtight conditions shall show which kits should be installed with the luminaire housing and how they shall be attached. A gasket shall be installed between the kit and the ceiling.
3. The following methods for ensuring an airtight seal between the certified airtight housing or certified airtight trim and the ceiling shall be field verified at different phases during construction:
- a. A gasket attached to the bottom of the certified airtight housing shall be inspected before the ceiling is installed when the rough-in electrical work is visible. The inspector shall review the cut sheet or installation instructions to ensure the housing and gasket have been correctly installed. All gaskets shall be permanently in place at the time of inspection. Once the ceiling material is installed, the gasket will be in continuous, compressed contact with the back of the ceiling and that the housing is securely attached to avoid vertical movement. The housing shall be installed on a plane parallel to the ceiling to ensure continuous compression of the gasket.
 - b. A gasket applied between the certified airtight housing and the ceiling after the ceiling has been installed shall be inspected after the ceiling has been installed. The inspector shall review the cut sheet or installation instructions to make sure the housing and gasket have been installed correctly. The gasket shall be permanently in place at the time of

inspection. It is important that the gasket is in continuous, compressed contact with the ceiling, and that the housing is attached securely to avoid vertical movement.

- c. Caulk applied between the certified airtight housing and the ceiling shall be inspected after the ceiling is installed. The inspector shall review the cut sheet or installation instructions to make sure the housing has been installed correctly and the caulk has been applied correctly. The housing should be attached securely to avoid vertical movement.

A certified airtight trim kit shall be inspected after the ceiling and the trim are installed. The inspector shall review the cut sheet or installation instructions to make sure the luminaire housing and the kit have been installed correctly. Both should be securely attached to avoid vertical movement. The ASTM E283 certification is a laboratory procedure where the trim kit is tested on a smooth mounting surface. It is common for the kits to be installed against a textured ceiling or other irregular ceiling surface. The gasket should be in continuous, compressed contact with the ceiling and the kit. Visually inspect the kit and gasket next to the ceiling to ensure a continuous seal. Kits may be installed on luminaire housings that may or may not be certified airtight. If the kit is certified airtight, it shall also have a sealed gasket between the kit and ceiling.

6.11 For Manufacturers – Certification to the Energy Commission

The following are guidelines for manufacturers to ensure their lighting products meet residential lighting requirements of the Energy Standards:

Light source products (luminaires, lamps and light sources) that are required to comply with Reference Joint Appendix JA8 shall be marked with JA8-2019 or JA8-2019-E.

For lighting control and light source products to be certified to the Energy Commission (as defined in §100.1), the manufacturer must comply with the requirements of certification. Certification and certification can be done on the Energy Commission's Certify My Product webpage, which is at <http://www.energy.ca.gov/appliances/>, and under the heading "Modernized Appliance Efficiency Database System (MAEDBS)". The procedures include filling out a certification packet and submitting a declaration of compliance, executed under penalty of perjury of the laws of California, that the regulated product meets the requirements.

Building departments, builders, contractors, and lighting designers also use the database to verify that a regulated product has been certified to the Energy Commission by the manufacturer.

Luminaires do not need to be shipped with a JA8 lamp by manufacturers.

6.11.1 Luminaires and Lamps and Other Light Sources Complying with JA8 and JA10

Joint Appendix JA8, “Qualification Requirements for High Efficacy Light Sources,” is a technical specification with requirements for high-efficacy light sources which can be luminaires or lamps.

Joint Appendix JA10, “Test Method for Measuring Flicker of Lighting Systems and Reporting Requirements,” is a supplement to the reduced flicker operation requirement of JA8. JA10 describes the test method to measure the flickering of light from the lighting system. The test involves using signal processing to remove high frequency components and quantifies flicker as a percent amplitude modulation below a given cut-off frequency.

In the 2019 Energy Standards, the testing procedures and the requirement for lumen maintenance and rated life, the start time and audible noise of JA8 have been harmonized with the ENERGY STAR® programs for lamps and for luminaires.

Product manufacturers wanting to meet requirements of the ENERGY STAR® program and JA8 of California Energy Code can use the following information to review applicable lamp and luminaire type for both standards. More information can be found at the ENERGY STAR® program.

6.11.2 Lamps and Luminaires Associated with ENERGY STAR® Programs

Lamps and luminaires associated with ENERGY STAR® program that meet JA8 of California Energy Code are in the following table as references.

Table 6-5: Lamps and Luminaires Associated with ENERGY STAR® Programs

ENERGY STAR® programs	Intended Products
ENERGY STAR® Program for Lamps	ANSI Standard Lamp Shape
	A, BT, P, PS, S and T
	B, BA, C, CA, DC, F, G, and ST
	R, BR, ER, MR, MRX and PAR
ENERGY STAR® Program for Luminaires	Directional luminaires with solid state light sources, including accent lights, cover mount and cabinet lights, downlights, outdoor lighting.
	Non-directional luminaires, including wrapped lens, wall sconces & retrofits, decorative pendants, ceiling mount & retrofits, linear strip, bath vanity, chandeliers, and outdoor ceiling or close-to-ceiling, porch or post mount.

	Inseparable SSL luminaires not listed as directional luminaires above.
--	--

Guidance on Luminaire Products in Meeting Lumen Maintenance and Rated Life Requirements

1. For Option 1 (for LED packages, LED modules or LED arrays including those incorporated into luminaires, retrofit kits and LED light engines - as allowed under the ENERGY STAR® program product specifications for Luminaires):
 - Either IES LM-80-08 and its Addendum A or IES TM-80-15 can be used for as the lumen maintenance measurement method.
2. For Option 2 (for LED luminaires, LED retrofit kits, or LED light engines):
 - IES LM-84-14 and TM-28-14 can be used as the lumen maintenance measurement method.

Guidance on Lamp Products in Meeting Lumen Maintenance and Rated Life Requirements

1. For LED lumen maintenance test method:
 - Besides the ENERGY STAR® Ambient Temperature Life test and Elevated Temperature Life test, either IES LM-80-08 and its Addendum A or IES TM-80-15 can be used.
2. For LED lumen maintenance projection method:
 - Either 10 CFR Part 430 Appendix BB to Subpart B, or IES TM-21-11 and its Addendum B can be used.
3. Linear or tubular lamp products can be tested under the ENERGY STAR® Product Specification for Lamps Version 2.1 for the Lumen Maintenance of Section 10 (ENERGY STAR® Lamps, Version 2.1). The products shall be tested in the horizontal position.

Light source products other than those mentioned above:

All other light sources (not covered in the intended scope of ENERGY STAR® Program for Lamps and for Luminaires; not linear and tubular lamps) can be tested as specified in Section 10 of the ENERGY STAR® Product Specification for Luminaire Version 2.1.

6.11.3 Marking Designation and Product Data Required for Certified JA8 Luminaires, Lamps and Light Sources

Certified JA8 products including luminaires, lamps and light sources shall have the marking showing it meets the requirement of Section JA8.5.

Table 6-6 shows different marking designations depending on the light source type.

Table 6-7 shows the product date to be submitted to the Energy Commission for meeting the requirements of Section JA8.6.

Table 6-6: Summary of Marking Designation for Certified JA8 luminaires, Lamps and Light Sources

Light Source Types	Marking Designation	Testing Notes for Meeting the Lumen Maintenance and Rated Life Requirements
1.Ceiling recessed downlight luminaires	JA8-2019	Ceiling recessed downlight luminaires that have passed rated life test of ENERGY STAR® Product Spec for Luminaire Version 2.1.
2.Lamps and Light Sources installed in enclosed or recessed luminaires	JA8-2019-E	Light sources that have passed the elevated temperature life test of ENERGY STAR® Product Spec for lamp Version 2.1; or the rated life test of ENERGY STAR® Product Spec for Luminaire Version 2.1.
3.Light Sources other than #1 and #2.	JA8-2019	Lighting sources tested per Section 10 of ENERGY STAR® Product Spec for Lamp Version 2.1 or per Section 10 of ENERGY STAR® Product Spec for Luminaire Version 2.1, and meet Section JA8.4.5.

Table 6-7: JA8 Data to Be Submitted to the California Energy Commission

METRIC	JA8 REQUIREMENTS
Light source type	LED, OLED, Fluorescent, HID, Incandescent, Other
Product type	Omnidirectional lamp, Directional lamp, Decorative lamp, LED light engine, Inseparable SSL luminaire, T20 lamp, Other
Lab accredited by NVLAP or accreditation body operating in accordance with ISO/IEC 17011?	Yes
Initial efficacy	≥ 45 lumens/W
Power factor at full rated power	≥ 0.90
Start time	≤ 0.5 sec
Correlated color temperature (CCT)	≤4000 K
Color rendering index (CRI)	≥ 90 for all products other than T20 lamps. ≥82 for T20 lamps
Color rendering R9 (red)	≥ 50 for all products other than T20 lamps
Ambient or elevated temperature test for rated life, lumen maintenance, and survival rate	Ambient or Elevated
Lumen maintenance	≥ 86.7% after final testing, or 93.1% if reporting interim data
Interim or final reporting	Interim or Final
Rated life	≥ 15,000 hours
Survival rate	≥ 90%
Minimum dimming level	≤ 10%
Dimming control compatibility	At least one type must be listed
NEMA SSL 7A compatible?	If compatible with forward phase cut dimmer control, "Yes." If not, "NA."
FLICKER:	
See JA10 Table 10-1 for flicker data requirements and permissible answers	<30% for frequencies of 200 Hz or below, at 100% light output
See JA10 Table 10-1 for flicker data requirements and permissible answers	<30% for frequencies of 200 Hz or below, at 20% light output
AUDIBLE NOISE:	
100% light output: Audible noise	≤ 24 Dba
20% light output: Audible noise	≤ 24 Dba
MARKING:	
Marked in accordance with JA8.5	Yes

Table of Contents

7. Photovoltaic, Community Shared Solar, Battery Storage, and Solar Ready Buildings	1
7.1 Overview	1
7.2 Prescriptive Requirements for Photovoltaic System	1
7.2.1 Photovoltaic System Size.....	1
7.2.2 Exceptions to PV requirements.....	2
7.2.3 Joint Appendix 11 (JA11) Requirements.....	4
7.3 Performance Approach Compliance for Photovoltaic System	8
7.3.1 Energy Budget Calculation.....	8
7.3.2 Exceptions to PV requirements.....	8
7.3.3 Additional Requirements.....	9
7.4 Community Shared Solar Electric Generation and Storage Systems	10
7.4.1 Photovoltaic System Size.....	10
7.4.2 Enforcement Agency.....	11
7.4.3 Energy Performance and Minimum Community Shared PV and Battery Storage Size.....	11
7.4.4 Dedicated Building Energy Savings and Bill Reduction Benefits.....	12
7.4.5 Durability.....	13
7.4.6 Additionality.....	13
7.5 Battery Storage System	15
7.5.1 Minimum Performance Requirements.....	16
7.5.2 Controls Requirements.....	16
7.5.3 Controls Strategies.....	17
7.5.4 Other Requirements.....	18
7.6 Solar Ready Overview	20
7.6.1 Covered Occupancies.....	20
7.6.2 Solar Zone.....	21
7.6.3 Azimuth (Solar Zone).....	27
7.6.4 Shading (Solar Zone).....	27
7.6.5 Structural Design Loads (Solar Zone).....	28
7.6.6 Interconnection Pathways.....	28
7.6.7 Documentation.....	29
7.6.8 Main Electrical Service Panel.....	29

7.7	California Fire Code Solar Access Requirements	29
7.8	Compliance and Enforcement	32

7 Photovoltaic, Community Shared Solar, Battery Storage, and Solar Ready Buildings

7.1 Overview

Chapter 7 describes the compliance requirements for photovoltaic (PV) systems, battery storage systems, and solar ready for newly constructed residential dwellings, including single-family, and low-rise (three or fewer habitable floors) multifamily buildings. The PV requirement is a new prescriptive requirement for newly constructed single-family and low-rise multifamily buildings. The prescriptive PV requirement also sets the standard design budget for the performance compliance method. Installation of battery storage system is a new compliance option for 2019 and this chapter describes the qualification requirement for this credit. The requirements for solar ready buildings are mandatory measures for newly constructed single-family homes and new low-rise multifamily residential buildings that do not have a photovoltaic system due to an exception in Section 150.1(c)14. The solar ready requirement is implemented when designing the building's rooftop and associated equipment. The intent is to reserve a penetration-free and shade-free portion of the roof for the potential future installation of a solar energy system. There are no requirements to install panels, conduit, piping, or mounting hardware.

For information about solar water heating system, please see Chapter 5.

7.2 Prescriptive Requirements for Photovoltaic System

7.2.1 Photovoltaic System Size

§150.1(c)14

To comply with the prescriptive requirements, all low-rise single family and multifamily buildings are required to have a PV system installed unless the building qualifies for an exception. The minimum qualifying size of the PV system is based on the projected annual electrical usage as described by the Equation 7-1 below.

Equation 7-1

$$kW_{PV} \text{ required} = (CFA \times A)/1000 + (ND_{well} \times B)$$

WHERE:

kW_{PV} = kW_{dc} size of the PV system

CFA = Conditioned floor area

ND_{well} = Number of dwelling units

A = Adjustment factor from Table 7-1

B = Dwelling adjustment factor from Table 7.1

Table 7-1 – CFA and Dwelling Adjustment Factors

<u>Climate Zone</u>	<u>A - CFA</u>	<u>B - Dwelling Units</u>
<u>1</u>	<u>0.793</u>	<u>1.27</u>
<u>2</u>	<u>0.621</u>	<u>1.22</u>
<u>3</u>	<u>0.628</u>	<u>1.12</u>
<u>4</u>	<u>0.586</u>	<u>1.21</u>
<u>5</u>	<u>0.585</u>	<u>1.06</u>
<u>6</u>	<u>0.594</u>	<u>1.23</u>
<u>7</u>	<u>0.572</u>	<u>1.15</u>
<u>8</u>	<u>0.586</u>	<u>1.37</u>
<u>9</u>	<u>0.613</u>	<u>1.36</u>
<u>10</u>	<u>0.627</u>	<u>1.41</u>
<u>11</u>	<u>0.836</u>	<u>1.44</u>
<u>12</u>	<u>0.613</u>	<u>1.40</u>
<u>13</u>	<u>0.894</u>	<u>1.51</u>
<u>14</u>	<u>0.741</u>	<u>1.26</u>
<u>15</u>	<u>1.56</u>	<u>1.47</u>
<u>16</u>	<u>0.59</u>	<u>1.22</u>

7.2.2 Exceptions to PV requirements

Annual Solar Access: The annual solar access is the ratio of solar insolation including shading over the solar insolation without shading. Refer to Example 7-12 for an example of how to calculate solar access.

Effective Annual Solar Access: The effective annual solar access shall be 70 percent or greater of the output of an unshaded PV array on an annual basis.

Effective Annual Solar Access Roof Areas: Are roof areas that meet the Effective Annual Solar Access requirements and are at least 80 contiguous square feet.

There are six allowable exceptions to the prescriptive PV requirements as listed below.

Exception 1 may apply if there is limited unshaded roof space. No PV is required if the effective annual solar access is restricted to less than 80 contiguous square feet by shading from existing permanent natural or manmade barriers external to the dwelling, including but not limited to trees, hills, and adjacent structures.

Exception 2 may apply to climate zone 15 and the required PV size may be reduced, if there is inadequate space on the roof to accommodate the PV size specified in Section 7.2.1. The PV size shall be the smaller of a size that can be accommodated by the Effective Annual Solar Access Roof Areas, or a PV size required by the equation above, but no less than 1.5 Watt DC per square foot of conditioned floor area.

Exception 3 may apply to two stories residential buildings and the required PV size may be reduced if there is inadequate space on the roof to accommodate the PV size specified in Section 7.2.1. The PV size shall be the smaller of a size that can be accommodated by the Effective Annual Solar Access Roof Areas, or a PV size required by the Equation 150.1-C, but no less than 1.0 Watt DC per square foot of conditioned floor area

Exception 4 may apply to three stories or higher residential buildings and the required PV size may be reduced if there is inadequate space on the roof to accommodate the PV size specified in Section 7.2.1. In all climate zones, for low-rise residential dwellings with three habitable stories and single family dwellings with three or more habitable stories, the PV size shall be the smaller of a size that can be accommodated by the Effective Annual Solar Access Roof Areas, or a PV size required by the Equation 150.1-C, but no less than 0.8 Watt DC per square foot of conditioned floor area.

Exception 5 For a dwelling unit plan that is approved by the planning department prior to January 1, 2020 with available solar ready zone between 80 and 200 square feet, the PV size is limited to the lesser of the size that can be accommodated by the effective annual solar access or a size that is required by the Equation 150.1-C.

Exception 6 may apply to buildings with battery storage system. The required PV sizes from Equation 7-1 may be reduced by 25 percent if a battery storage system is installed. For single family building, the minimum capacity of the battery storage system must be at least 7.5 kWh. For multifamily buildings, the battery storage system must have a minimum total capacity equivalent to 7.5 kWh per dwelling. In all case the battery storage needs to meet the qualification requirements specified in Joint Appendix JA12 and be listed with CEC.

Example 7-1 Exceptions

Question:

I'm an energy analyst simulating a 2-story building, can you explain in plain English the requirements of exception 2 for climate zone 15, exception 3 for 2-story buildings, and exception 4 for 3-story buildings?

Answer:

Exceptions 2, 3, and 4 were created to account for unusual roofs that may not have enough space to accommodate the PV size that would offset the annual kWh of the dwelling. If the exception is used, the requirement is to install as much PV capacity as

possible, but no less than 1.5 Wdc per square foot in CZ 15, or 1 Wdc per square foot for 2-story buildings, or 0.8 Wdc per square foot for 3-story buildings.

Example 7-2

Question:

How do you demonstrate compliance with the exception 3 to the PV sizing requirements for a 2-story building?

Answer:

If the energy analyst does not know have the roof layout plan or does not anticipate a roof area limitation issue, then the building must be modeled without the exception (prior to final approval, the energy analyst may update the simulation run and resubmit the updated CF1R, if the roof plans become available and indicate an area limitation issue). However, if the energy analyst has the roof plans that indicate area limitation, then exception 2 may be used to model the building. If the exception is used, then the energy analyst must specify, in the compliance software or CF1R, the maximum PV size that can be accommodated by the roof, but no less than 1 Wdc per square foot. If the exception is used, prior to final approval, proof must be provided that documents roof area limitations that justifies using the exception. Documentation may include roof plans, aerial photos, satellite images, 3D model, or other documentation that clearly shows the available roof areas that meets the solar access requirements.

Compliance with exceptions 2 and 4 follows the same procedure as above.

7.2.3 Joint Appendix 11 (JA11) Requirements

The installed PV system must meet the applicable requirements specified in JA11.

7.2.3.1 System Orientation

For prescriptive path compliance, if a PV system is installed with a pitch greater than 2:12 or 10 degrees, the arrays must be oriented between 90 to 300 degrees from true north. If the pitch is less than 10 degrees, then it is considered a low-slope (flat) installation, and orientation has insignificant impact on the array's performance and therefore it can be ignored.

When using the performance approach, the array may be oriented in any direction, including due north; however, the more the orientation deviates from the optimum orientation of southwest, the worse the system performs, resulting in a larger PV system size needed to achieve compliance. So, it is best to orient the panels as close to southwest as possible to maximize the system performance with the smallest array size.

In order to use the California Flexible Installation (CFI) simplified modeling option in the performance method, the PV array must be installed between 150 to 270 degrees from true north, with all modules at the same tilt as the roof for pitches up to 7:12.

7.2.3.2 Shading

For prescriptive path compliance, the PV system must not have any obstruction to the array. Obstructions include the following:

- (a) Any vent, chimney, architectural feature, mechanical equipment, or other obstruction that is on the roof or any other part of the building.
- (b) Any part of the neighboring terrain.
- (c) Any tree that is mature at the time of installation of the PV system.
- (d) Any tree that is planted on the building lot or neighboring lots or planned to be planted as part of landscaping for the building. (The expected shading shall be based on the mature height of the tree.)
- (e) Any existing neighboring building or structure.
- (f) Any planned neighboring building or structure that is known to the applicant or building owner.
- (g) Any telephone or other utility pole that is closer than 30 feet from the nearest point of the array.

In general, the distance between edges of the arrays and any obstruction must be at least twice the height of the obstruction that extends above the PV array as seen in Figure 7-1 below. Note that any obstruction located north of the array does not count as shading obstruction.

Figure 7-1: The Minimal Shading Criterion Artistic Depiction of "H" and "D"

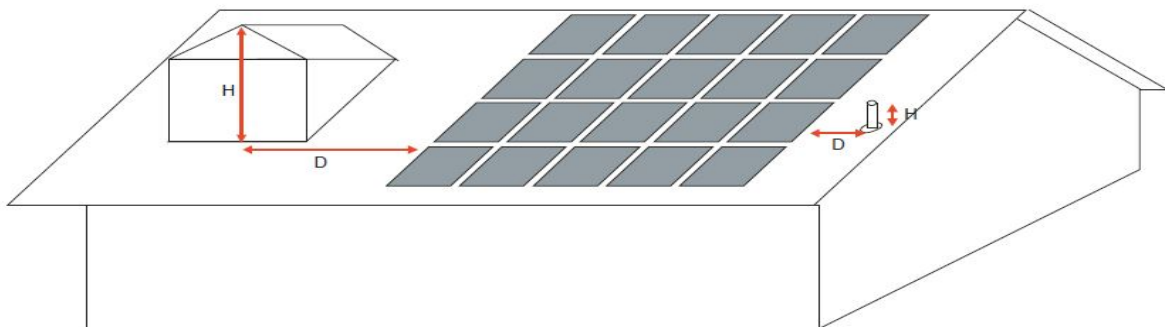

For performance path compliance, if there is any shading to the array, the detail orientation and location must be input in the software.

In summary, if the arrays are unshaded, then both prescriptive and performance methods can be used to demonstrate compliance with the Standards; however, if an array is shaded, then the detailed approach under the performance method must be used to model the actual shading conditions of the arrays. For more information on software inputs, please refer to the software user's manual.

Example 7-3 Shading

Question:

What would be the impact of shading on the PV sizing requirement?

Answer:

Prescriptively the PV array cannot have any shading and must meet the minimum shading criteria in JA11. Under the performance path the shading condition must be modeled as it is present, and it will result in a larger PV size that meets the same TDV budget as a smaller unshaded PV system.

7.2.3.3 Solar Access Verification

A solar assessment tool that is approved by the Executive Director must be used to document the shading conditions of the PV system. Measurements shall be made at all the major corners of the array. Additional measurements will be needed if they are more than 40 feet apart, and the additional points of measurement should be evenly distributed evenly. See Figure 7-2 for example of measurement locations for a typical roof.

Figure 7-2: Example of Points Where Measurement Shall Be Made Using a Solar Assessment Tool

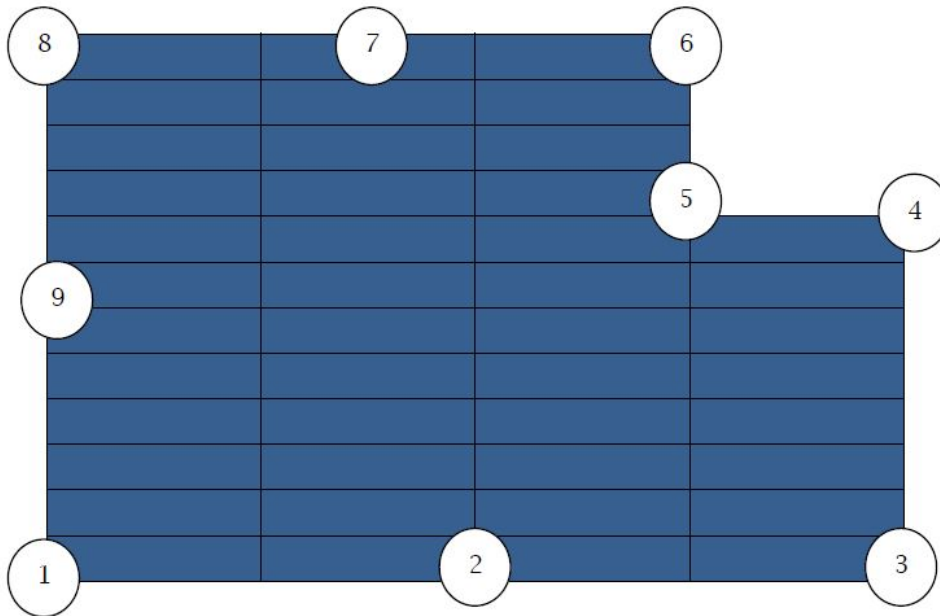

The approved solar assessment tool can be a physical tool that measures the available solar energy at the installation site, or software based tool that model the physical

features of the building and surrounding shading conditions including roofs and trees, and then calculates their solar potential by analyzing it against historical weather data.

The installer must provide documentation that verifies the shading conditions of the array(s). This is done by using a CEC approved solar assessment tool or CEC approved alternative verification method

Alternative Methods - Aerial photos that document the positions of shading obstructions in relation to the location of the array may be used as an alternative to solar assessment tools. These methods include satellite images, drone images, digital images taken using long masts or from adjacent high grounds or structures. These images must provide unobstructed, sharp, and clear view of the PV array(s) and nearby obstructions casting shadows. The images must document:

- a. Images' horizontal distance scale
- b. The location of the array(s)
- c. The position of the obstruction(s) and their height above the array(s)
- d. The horizontal distance between the obstruction(s) and nearest point of the array(s)

The Executive Director may approve additional alternate methods that can be used to evaluate the solar access availability of the location.

7.2.3.4 Remote Monitoring Capability

The PV system must have a web portal and a mobile device application that enable the occupants monitor the performance of their PV system, to identify, report, and correct performance issues with the panels, inverters, shading, or other issues that may adversely impact the performance of the PV system. At a minimum, the occupants must have access to the following information:

- (a) The nominal kW rating the PV system.
- (b) Number of PV modules and the nominal watt rating of each module.
- (c) Hourly (or 15-minute interval), daily, monthly, and annual kWh production in numeric and graphic formats for the system.
- (d) Running total of daily kWh production.
- (e) Daily kW peak power production.
- (f) Current kW production of the entire PV system.

7.2.3.5 Additional Requirements

In addition to the requirements above, the PV system must also meet the following requirements in JA11:

Interconnection Requirements: All inverters in the PV system must comply with the CPUC Electric Tariff Rule 21, which governs CPUC-jurisdictional interconnections for all

net energy metering (NEM) customers. Rule 21 requires that inverters have certain capabilities to ensure proper operation of the electrical grid as more renewables are interconnected. The inverters must perform functions that when activated, can autonomously contribute to grid support during excursions from normal operating voltage and frequency system conditions by providing dynamic reactive/real power support, voltage and frequency ride-through, ramp rate controls, communication systems with ability to accept external commands and other functions.

Certificates and Availability: The PV installer shall certify on the Certificate of Installation that all provisions of JA11 are met and provide PV array geometries used in the performance calculation if applicable. The Certificate of Installation shall be available on the building site for inspections.

Enforcement Agency Responsibilities: The local enforcement agency shall verify that the Certificate of Installation is valid complete and correct, and uploaded into a Commission-approved registry.

Example 7-4 Remote Monitoring**Question:**

How do I implement monitoring to meet section JA11.5.1 including the current reading?

Answer:

There are multiple options. Many inverters can connect via ethernet and wireless to the homeowner's internet, and others use independent cellular connections. For cellular, the data should be updated to the monitoring portal periodically as allowed by the cellular plan.

7.3 Performance Approach Compliance for Photovoltaic System

7.3.1 Energy Budget Calculation

The computer performance approach allows for the modeling of the PV system performance by taking into account PV system size, climate, panel orientations, inverter efficiency, and shading characteristics. The standard design PV system size is determined by the modeled annual electrical consumption of the mixed-fuel proposed design building, regardless of the actual fuel type of the proposed design building. The performance method allows for modeling different PV sizes, solar thermal systems, more energy efficiency measures, battery storage system and other demand response measures.

7.3.2 Exceptions to PV requirements

The six allowable exceptions to the prescriptive PV requirements listed in 7.2.2. can also be used under the performance approach. User must select the appropriate exception in the software and provide documentation to the building department with the building permit application.

7.3.3 Additional Requirements

The installed PV system must meet the applicable requirements as specified in JA11.

Example 7-5 Efficiency Tradeoff

Question:

Does the performance path allow tradeoffs between PV systems and energy efficiency measures? How about tradeoffs between a PV system that is couple with a battery storage system and energy efficiency measures? How about a standalone battery storage system?

Answer:

Beginning with the 2019 Standards, the performance path no longer allows installing a larger PV system in exchange for less energy efficiency measures; however, the software will allow installing more energy efficiency, demand responsive measures, battery and storage and thermal storage systems in exchange for a smaller PV system.

When the PV systems is coupled with at least a 5 kWh battery storage system, the performance path will allow a portion of the available credit to be used for efficiency measure tradeoffs; this is a modest credit that can be used to achieve compliance in buildings that have marginal difficulty achieving compliance.

The Standards do not recognize standalone battery storage systems that are not coupled with a PV system and no compliance credits are granted for these systems.

Example 7-6 Solar Thermal System

Question:

Does a solar thermal water heating system still qualify for compliance credit in the performance path?

Answer:

Yes, although a solar water heating system cannot serve as a substitution for the prescriptively required PV system, it can still be installed along with PV for optional compliance credit in the performance path. Solar water heating systems are modeled along with the remainder of the water heating and distribution systems as part of the efficiency EDR score, and can be used for efficiency measures tradeoff, or installing a

smaller PV system. The requirements for solar thermal water heating systems are described in Chapter 5, Water Heating Requirements.

Example 7-7 Precooling

Question:

Can you explain precooling strategy requirements and how to comply with them?

Answer:

Precooling is a strategy that allows cooling the house by two or three degrees below the setpoint in the hours preceding the onset of peak time-of-use (TOU) hours, when the electricity rates are relatively low, and then turning off the air conditioning during the TOU peak hours, resulting in significant cost savings for the building occupants.

To obtain this credit, a JA5 compliant communicating thermostat must be installed in the dwelling unit, and indicated on both CF1R and CF2R forms.

The precooling credit may only be used to lower the EDR score towards a more stringent EDR goal set by a reach code such as a local ordinance; this credit cannot be used to tradeoff the energy efficiency features of the building.

Finally, if the dwelling unit is already equipped with a battery storage system coupled with a PV system, the precooling strategy may have negligible impact on further lowering the EDR score.

7.4 Community Shared Solar Electric Generation and Storage Systems

7.4.1 Photovoltaic System Size

§150.1(c)14

The 2019 Building Energy Efficiency Standards allow the possibility for the Standards requirements for photovoltaics on the site of the residential building to be fully or partially offset by Community Shared Solar Electric Generation. Community Shared Solar Electric Generation means solar electric generation or other renewable technology electric generation that is installed at a different site. Also, the batteries that can be installed in combination with photovoltaics on the building site to gain performance standards compliance credit can be fully or partially offset by Community Shared Battery Storage Systems that are installed at a different site. Community Shared Solar Electric Generation Systems and Community Shared Battery Storage Systems could be installed in combination or separately. Such systems are hereinafter referred to just as Community Shared Solar Generation Systems.

For these offsets to become available, entities who wish to serve as administrators of a proposed Community Shared Solar Electric Generation System must apply to the Energy Commission for approval, demonstrating that several criteria specified in Section 10-115 of the Standards are met, to ensure that the Community Shared Solar Generation System provides equivalent benefits to the residential building expected to occur if photovoltaics

or batteries had been installed on the building site. The Energy Commission will carefully consider these applications to determine if they meet these criteria. If approved, Energy Commission approved compliance software will be modified to enable users to take compliance credit for buildings served by that Energy Commission approved Community Shared Solar Electric Generation System.

Any entity may apply to serve as administrator of a proposed Community Shared Solar Electric Generation System, including but not limited to utilities, builders, solar companies or local governments. The entity will be responsible for ensuring that the criteria for approval are met throughout (at least) a twenty-year period for each building that uses shares of the Community Shared Solar Electric Generation System for partial or full offset of the onsite solar electric generation and batteries, which would otherwise be required for the building to comply with the Standards. Throughout that period the administrator will be accountable to builders, building owners, enforcement agencies, the Energy Commission, and other parties who relied on these systems for offset of full or partial compliance with the Standards. Records demonstrating compliance with the criteria must be maintained over that period, with access to those records provided to any entity approved by the Energy Commission.

Entities interested in applying to serve as administrator of a proposed Community Shared Solar Electric Generation System should become thoroughly familiar with the criteria for approval specified in Section 10-115, and contact the Energy Commission Building Standards Office for further discussion and explanation of the criteria as necessary.

In general, the Community Shared Solar Electric Generation System must meet the following:

7.4.2 Enforcement Agency

The Community Shared Solar Electric Generation System must exist and be available for enforcement agency review early in the permitting process, and shall not cause delay in the in enforcement agency review and approval of the building that will be served by the Community Shared Solar Generation System. All documentation required to demonstrate compliance for the building and the compliance offset from the Community Shared Solar Electric Generation System shall be completed and submitted to the enforcement agency with the permit application. The enforcement agency must be provided facilitated access to the Community Shared Solar Electric Generation System to verify the validity and accuracy of compliance documentation.

7.4.3 Energy Performance and Minimum Community Shared PV and Battery Storage Size

Energy Commission approved compliance software must be used to show that the energy performance of the building's share of the Community Shared Solar Electric

Generation System is equal to or greater than the partial or full offset claimed for the solar electric generation and batteries, which would otherwise be required for the building to comply with the Standards.

The minimum community shared solar size dedicated to the building and the annual kWh equivalence may be measured in one of two ways: (1) Using the CBECC-Res Simplified approach for PVs and the CFI orientation option, or (2) by modeling the actual attributes of the system using the detailed approach. When the detailed approach is used, the compliance software will determine a minimum kW size that will represent the portion of the community solar resource dedicated to the building, based on PV system component performance characteristics, azimuth (orientation and tilt), inverter type, tracking versus fixed systems, climate zone and CEC weather files containing solar availability data.

Additionally, If the community shared solar resources is coupled with a community shared battery storage system, in the CBECC-Res, the modeled PV system must also be coupled with at least a 5 kWh battery storage system to determine the size share of the community solar resource dedicated to the building. Also, the portion of the community shared battery storage system dedicated to the dwelling must match the battery storage size modeled in CBECC-Res.

7.4.4 Dedicated Building Energy Savings and Bill Reduction Benefits

A specific share of the Community Shared Solar Electric Generation System, determined to comply with the Energy Performance requirement above, must be dedicated on an ongoing basis to the building. The energy savings benefits dedicated to the building shall be provided in one of the following ways:

- A. Actual reductions in the energy consumption of the building;
- B. Utility energy reduction credits that will result in virtual reductions in the building's energy consumption, including but not limited to generation credit, solar charge, program charge, and power charge indifference adjustment (PCIA) charge; or
- C. Payments to the building that will have an equivalent effect as energy bill reductions that would result from one of the other two options above.

For all three options mentioned above, the reduction in energy bills resulting from the share of the Community Shared Solar Electric Generation System dedicated to the building shall be greater than the cost that is charged to the building to obtain that share of the Community Shared Solar Electric Generation System. In other words, a building that participates in an approved community solar program, cannot be charged more than the same but nonparticipating building that has no onsite PV system and does not participate in a community solar program.

7.4.5 Durability

The benefits from the specific share of the Community Shared Solar Electric Generation System must be provided to each dedicated building for a period not less than 20 years.

7.4.6 Additionality

The specific share of the Community Shared Solar Electric Generation System must provide the benefits to the dedicated building that are in no way made available or attributed to any other building or purpose. Renewable Energy Credits that are unbundled from the Community Shared Solar Electric Generation System do not meet this additionality requirement.

Example 7-8

Question:

To help entities that might want to apply to the Energy Commission for approval of a Community Shared Solar Energy Generation System, please provide examples of each of the three optional ways energy savings benefits could be provided to comply with Section 7.4.3.2.3.

Answer:

Examples would include:

Actual reductions in the energy consumption of the building: This could be accomplished by locating the PV systems for several houses on a carport on common land in a subdivision, and direct wiring the unique PV panels serving each house to an inverter that is located on the home's site. For homes served by utilities that are subject to compliance with Net Energy Metering requirements, the common land that is hosting the PVs on the carport would have to be adjacent to (could be directly across a street) the houses that are being served by the PV system. All other requirements of Section 10-115 would have to be met.

Utility energy reduction credits that will result in virtual reductions in the building's energy consumption that is subject to energy bill payments: This could be accomplished for qualifying multi-family dwellings by participation in an approved virtual net metering program, which has PVs installed on the multi-family project site, and energy bill credits that reduce each dwelling unit's monthly electricity bill consistent with Net Energy Metering requirements. Alternatively, this could be accomplished through a community shared solar program administered by a utility (like the Green Tariff Shared Renewables, or GTSR), for which a remote renewable resource is paid for through shares purchased for each home, and energy bill credits are that reduce monthly electricity bills are allocated based on the homes' shares, including but not limited to

generation credit, solar charges, program charges, and nonparticipant charges. All other requirements of Section 10-115 would have to be met.

Payments to the building that will have an equivalent effect as energy bill reductions that would result from one of the two options above: This could be accomplished by builders installing PV systems on other properties they own to offset the compliance requirement for onsite PVs on homes they build. The homes would pay for a share of the PV systems on the other properties. The builders would be obligated to make an ongoing cash payment back to the homes for the home's share of the electricity generation achieved by the PV systems on the other properties. The share of the ownership of the PV systems on the other properties and the corresponding sharing of the electricity generation achieved by the PV systems on the other properties would not be accounted for through a utility system – the ownership share would not be paid to the utility and the payment for the share of the electricity generation achieved by the PV systems on the other properties would not be provided through a utility bill. The entire program would be administered by the builder for a 20-year period for each home. All other requirements of Section 10-115 would have to be met.

Example 7-9

Question

Could you also explain what the cost requirements are in the last sentence of Section 7.4.3.2.3 that says: "In other words, a building that participates in an approved community solar program, cannot be charged more than the same but nonparticipating building that has no onsite PV system and does not participate in a community solar program."

Answer

In a nut shell, regardless of the three options above is chosen, it must be cost effective to the home for the home to participate in a community shared solar electric generation system program. The home will pay for its share of the community renewable resource, and will receive either energy bill reductions, credits or cash payments for the electricity that is generated by the community renewable resource. The \$ value of the bill reductions, credits or cash payments must exceed the cost to the home to pay for its share of the community renewable resource.

Let's take a hypothetical example of a Green Tariff Shared Renewables Program (GTSR) that is required by statute to be operated by the Investor Owned Utilities. The following shows the costs that the program charges a home to obtain shares of the program's

community solar resources, and the energy bill credit. The charges and credit are allocated per kWh generated by the home's share of the community renewable resource.

Example Green Tariff Shared Renewables Program Details	
Solar Charge	6.48 cents per kWh
Program Charge	2.956 cents per kWh
Power Charge Indifference Adjustment (PCIA) Charge	3.346 cents per kWh
Total Program Charges	12.782 cents per kWh
Generation Credit	-10.78 cents per kWh

The total cost that the home pays per kWh for its share of the community renewable resource is 12.8 cents per kWh and the energy bill credits for generation from the home's share of the community renewable resource is 10.8 cents per kWh. Since the value of the home's energy bill credit does not exceed the cost for the home to participate in the community solar program, the cost requirement of Section 7.4.3.2.3 is not met. Cost requirements can be brought into compliance through a combination of an increase in the generation credit and reductions in solar charge, program charge, and power charge indifference adjustment (PCIA) charge. In this example, if the generation credit raises by one cent, up to 11.8 cents, and combined charges decrease by 1.1 cents, down to 11.7 cents, then the program meets the cost requirements of Section 7.4.3.2.3.

7.5 Battery Storage System

The primary function of the battery storage system is to grid harmonize the onsite PV system with the grid, to bring maximum benefits to the grid, environment, and the occupants.

Grid Harmonization: For the purpose of Building Standards, grid harmonization is defined as strategies and measures that harmonize customer owned distributed energy resources assets with the grid to maximize self-utilization of PV array output, and limit grid exports to periods beneficial to the grid and the ratepayer. This is done by charging the battery from the PV system when there is limited electrical load at the building and the cost of electricity is low in midday, and discharging when the cost of electricity is high, usually in the late afternoon and early evening hours.

Battery storage system is available as a compliance credit in the performance compliance method and also as Exception 6 to the prescriptive PV requirements in section 150.1. In all cases, the battery storage system must meet all applicable requirements in Joint Appendix JA12 and be self-certified to CEC by the manufacturer as a qualified product.

Coupling a PV system with a battery storage system and appropriate control strategy described in Section 7.5.2 below, allow reaching specific target Energy Design Rating Targets (EDR) with a smaller PV system than otherwise would have been possible. This is a useful and cost effective strategy for meeting lower target EDRs that may be required by reach codes, with a smaller and grid harmonized PV system.

The list of qualified JA12 product list can be found here:

http://www.energy.ca.gov/title24/equipment_cert/

7.5.1 Minimum Performance Requirements

JA12 specifies that the battery storage system must meet or exceed the following performance specifications:

- a. Usable capacity of at least 5 kWh.
- b. Single Charge-discharge cycle AC to AC (round-trip) efficiency of at least 80 percent.
- c. Energy capacity retention of 70 percent of nameplate capacity after 4,000 cycles covered by a warranty, or 70 percent of nameplate capacity under a 10-year warranty.

7.5.2 Controls Requirements

Battery storage systems that remain in backup mode indefinitely, bring no grid benefits. The JA12 requirements are designed to ensure that the battery storage system remains in an active control mode and prevent the battery storage system from remaining in the backup mode indefinitely. These requirements also enable the battery storage system receive the latest firmware, software, control strategy, and other important updates.

The following JA12 requirements apply to all control strategies, including Basic Control, Time-of-Use (TOU) Control, and Advanced Demand Response Control, described in Section 7.5.3 below:

1. The battery storage system shall have the capability of being remotely programmed to change the charge and discharge periods.
2. During discharge, the battery storage system shall be programmed to first meet the electrical load of the dwelling unit(s). If during the discharge period the electrical load of the dwelling unit(s) is less than the maximum discharge rate, the battery storage system shall have the capability to discharge electricity into the grid upon receipt of a demand response signal from the local utility or a third-party aggregator.
3. The battery storage system shall operate in one of the control strategies listed in JA12.2.3.1, JA12.2.3.2, and JA12.2.3.3 except during a power interruption, when it may switch to backup mode. If the battery system switches to backup power mode during a power interruption, upon restoration of power the battery system shall immediately revert to the previously programmed JA12 control strategy. The device must have the algorithm that would enable export to be built in at the time of installation. It can be in the off mode and be turned on later with a remote signal.

4. The battery storage system shall perform a system check on the following dates, to ensure the battery is operating in one of the control strategies listed section 7.5.3 below:
 - a. Within 10 calendar days before the onset of summer TOU schedule, and
 - b. Within 10 calendar days before the onset of winter TOU schedule

If the local utility does not offer TOU rate schedule, the default system check dates should be 1 May and 1 November.

7.5.3 Controls Strategies

JA12 includes three control strategies that are designed to encourage charging the batteries when electricity prices are low, generally in the middle of the day when solar resources are plentiful and demand is low, and discharge the batteries later in the day when demand is high and solar resources are diminished:

Basic Control: Designed as a simple control that can be employed as the default control in the absence of TOU or Advanced Demand Response Controls, or where communication between batteries and outside parties are not possible. This control strategy does not allow discharging into the grid. To qualify for the Basic Control, the battery storage system shall be installed in the default operation mode to allow charging only from an on-site photovoltaic system when the photovoltaic system production is greater than the on-site electrical load. The battery storage system shall discharge only when the photovoltaic system production is less than the on-site electrical load.

Time-of-Use (TOU) Control: Designed to take advantage of TOU rates where they are available. This control strategy generally results in a greater Energy Design Rating (EDR) impact than the Basic Control. This control strategy does not allow discharging into the grid. To qualify for the TOU Control, the battery storage system shall be installed in the default operation mode to allow charging from an on-site photovoltaic system. The battery storage system shall begin discharging during the highest priced TOU hours of the day. The operation schedule shall be preprogrammed from factory, updated remotely, or programmed during the installation/commissioning of the system. At a minimum, the system shall be capable of programming three separate seasonal TOU schedules, such as spring, summer, and winter.

Advanced Demand Response Control: Designed to bring the maximum value to the PV system generations by placing the charge/discharge functions of the battery storage system under the control of a utility or a third party aggregator. This is the only control strategy that allows discharging into the grid upon receiving a demand response signal from a grid operator. This option requires robust communication capabilities between the battery storage system and the local utility or the third party aggregator. To qualify for the Advanced Demand Response Control, the battery storage system shall be programmed by default as Basic Control or TOU control as described above. The battery storage control shall meet the demand responsive control requirements specified in Section 110.12(a). Additionally, the battery storage

system shall have the capability to change the charging and discharging periods in response to signals from the local utility or a third-party aggregator

Alternative Control Approved by the Executive Director: The Commission recognizes that there may be other control strategies that bring equal or greater benefits than the ones listed above, therefore, the Executive Director may approve alternative control strategies that demonstrate equal or greater benefits to ones listed above in Section 7.5.2. To qualify for Alternative Control, the battery storage system shall be operated in a manner that increases self-utilization of the PV array output, responds to utility rates, responds to demand response signals, and/or other strategies that achieve equal or greater. This alternative control option shall be accompanied with clear and easy to implement algorithms for incorporation into the compliance software for compliance credit calculations.

7.5.4 Other Requirements

In addition to the requirements above, the battery storage system must also meet the following requirements in JA12:

Safety Requirements: The battery storage system shall be tested in accordance with the applicable requirements given in UL1973 and UL9540. Inverters used with battery storage systems shall be tested in accordance with the applicable requirements in UL1741 and UL1741 Supplement A.

Interconnection and Net Energy Metering Requirements: The battery storage system and the associated components, including inverters, shall comply with all applicable requirements specified in Rule 21 and Net Energy Metering (NEM) rules as adopted by the California Public Utilities Commission (CPUC).

Enforcement Agency: The local enforcement agency shall verify that all Certificate of Installations are valid. The battery storage systems shall be verified as a model certified to the Energy Commission as qualified for credit as a battery storage system. In addition, the enforcement agency shall verify that the battery storage system is programmed and operational with one of the control listed in Section 7.5.2 above. The programmed control strategy at system final inspection and commissioning shall be the strategy that was used in the Certificate of Compliance.

Example 7-10 Battery Storage Credit

Question:

Can you explain the battery storage credit requirements and how to comply with them?

Answer:

The performance path allows a compliance credit for a battery storage system with at least a 5 kWh capacity that is coupled with a PV system; standalone battery storage

systems are ineligible for a compliance credit. The PV/storage credit may be used to lower the EDR score towards a more stringent EDR goal set by a reach code such as a local ordinance; however, the software will allow a portion of the available credit to be used for efficiency measures tradeoff; this is a modest credit that can be used to achieve compliance in buildings that have marginal difficulty achieving compliance.

The manufacturers must self-certify to the Commission that the battery storage systems meet the requirements of JA12. JA12 lists minimum performance requirements, communication requirements, control requirements, safety requirements, and interconnection requirements, among others that must be complied with and certified to the Commission. The self-certification form may be downloaded from the Commission's website:

Example 7-11 Battery Storage Credit

Question:

When batteries are used there is a loss of electricity associated with the roundtrip charge and discharge resulting in fewer generated kWh. Why does the Commission provide a compliance credit for a battery storage system that is coupled with a PV system if there is a loss of energy?

Answer:

Battery storage systems store the PV generated electricity in the middle of the day when the solar resources are generally plentiful and electricity prices are low. The systems discharge the stored electricity later in the day, during the peak hours when solar resources are diminished and electricity prices are high. Battery storage systems have a roundtrip charge and discharge loss of 5 to 15 percent, depending on the type of battery technology and the inverter efficiencies. A compliance credit is available because the electricity price differential between the middle of the day and the peak hours is greater than the battery charge and discharge losses. This means that even with the relatively small loss of electricity it is still cost effective for a consumer to store electricity generated onsite around midday and use it later on instead of purchasing additional electricity from the grid.

To calculate the compliance credit of a battery storage system coupled with a PV system, the Energy Commission's compliance software on hourly basis accounts for the PV generation, losses, storage capacity remaining, charge and discharge rates, cost of electricity, house loads, and hourly exports. Similar calculations are also performed to calculate the benefits of storage for CO2 emissions.

Not any battery storage system is eligible for compliance credit; it must comply with the requirements of Reference Joint Appendix 12 (JA12). The requirements ensure that the battery storage system remains in a dynamic mode that allows residents to take

advantage of variable electricity costs associated with charge and discharge periods throughout the day. Static batteries that remain mostly in backup mode have little to no value to the homeowner, the grid, or the environment.

Example 7-12 Battery Storage TOU schedule

Question:

How will control requirement be enforced for customers that are not on a TOU schedule? How about customers on TOU rate but wants to be in Basic Control?

Answer:

If the local utility does not have TOU schedule, to comply with JA12.2.3 the battery storage system should perform a system check on 1 May and 1 November by default. A customer can set the control strategy to Basic Control, regardless of whether a TOU rate is available for the customer; however, this strategy will reduce the benefits of the battery storage for both the customer and the grid, and therefore is not recommended.

7.6 Solar Ready Overview

The solar ready provisions are mandatory for low-rise residential buildings that do not have a PV system due to an exception in Section 150.1(c)14. There are exceptions to the “solar zone” requirements, and these are described in the corresponding sections of this chapter. Because solar ready is mandatory, CF1R-SRA-01-E compliance forms must be submitted with the building permit application, even when using an allowable solar zone exception.

Please note: In §110.10 of the *Energy Standards*, the solar zone, interconnection pathways, and design load requirements for low-rise multifamily buildings are located with the high-rise multifamily requirements in §110.10(b)1B. Because most of the low-rise multifamily requirements are identical to high-rise (including three Exceptions), Chapter 9 of the “Nonresidential Compliance Manual” is an additional resource for technical assistance.

7.6.1 Covered Occupancies

§110.10(a)

The low-rise residential solar-ready requirements only apply to new single-family homes and low-rise multifamily buildings that do not have a PV system, as described in A and B below.

A. Single-Family Residential Buildings

The solar-ready requirements apply to the following newly constructed single-family homes without a PV system, and:

- located in a subdivision with 10 or more residences and
- the Tentative Subdivision Map is complete and approved by the enforcement agency.

B. Low-rise Multifamily Residential Buildings

The solar ready requirements apply to low-rise multifamily buildings having three habitable stories or fewer without a PV system.

A note about Mixed Occupancy Buildings: The Energy Standards apply to mixed occupancy buildings. Low-rise buildings with nonresidential space on the ground floor and multi-family residential floors above are common examples. The Solar Zone requirements include mixed occupancy buildings.

7.6.2 Solar Zone

§110.10(b)

The solar zone is a suitable place where solar panels can be installed at a future date - if the owner chooses to do so. A solar zone area is designed with no penetrations, obstructions or significant shade. The solar zone must comply with the access, pathway, smoke ventilation, and spacing requirements in Title 24 Part 9. Requirements from the other parts of Title 24, and those adopted by a local jurisdiction should also be incorporated in the solar zone design.

For single-family homes, the solar zone must be located on its roof or overhang.

For low-rise multifamily buildings, the solar zone can be located on any of the following locations:

1. Roof of the building.
2. Overhang of the building.
3. Roof or overhang of another structure located within 250 feet of the primary building.
4. Covered parking installed with the building project.

See Figure 7-6 for some acceptable solar zone placement techniques.

7.6.2.1 Solar Zone Minimum Area

§110.10(b)1

The total area of the solar zone may be composed of multiple subareas - if they meet minimum size specifications. No dimension of a subarea can be less than five feet. If the total roof area is equal to or less than 10,000 square feet, each subarea must be at least 80 square feet. If the total roof area is greater than 10,000 square feet, each subarea must be at least 160 square feet.

7.6.2.2 Solar Zone Area for Single-Family Residential Buildings

The solar zone must be located on the roof or overhang of the building. The “designated” solar zone’s total area must be no less than 250 square feet (§110.10(b)1A).

There are six allowable exceptions to the required solar zone area. Exceptions 1 and 6 allow alternate efficiency measures instead of an actual solar zone, so the requirements for zone shading, azimuth and design load; interconnection pathway, owner documentation, and electric service panel do not apply either.

Submit a CF1R-SRA-01-E to the building department with the building permit application for all projects covered by solar ready, even when using a Solar Zone Exception. In addition, submit a CF1R-SRA-02-E solar zone worksheet for all projects with a solar zone, including Exceptions that allow a reduced solar zone area.

Solar Zone Exceptions for Single-family Buildings:

Exception 1 may apply when a domestic solar water-heating (SWH) system is permanently installed at the time of construction. The SWH system must comply with the installation criteria in the Reference Residential Appendix RA4, and have a minimum solar savings fraction of 0.50. Note: These buildings are also exempt from the interconnection pathway, documentation and electrical panel requirements because there is no solar zone.

Exception 2 may apply if the single-family home has three or more habitable stories and a total floor area $\leq 2,000$ square feet. The designated solar zone may be reduced. The area must be ≥ 150 square feet.

Exception 3 may apply if the single-family home is in the Wildland-Urban Interface Fire Area (as defined in Title 24, Part 2). The solar zone area may be reduced to ≥ 150 square feet. In addition, a whole-house fan must be permanently installed at the time of construction. This exception is intended to accommodate attic- and roof-venting requirements in these fire areas.

New in the 2019 Energy Standards: this exception may be used in all Climate Zones.

Exception 4 reduces the solar zone area when the roof is shaded by objects that are not part of the building project, and therefore beyond the designer’s control. The designated solar zone may be reduced to ≥ 50 percent of the potential solar zone area when solar access is limited as described below. When the “potential” solar zone is smaller than the 250 square feet minimum, the solar zone can be reduced to half the area of the potential solar zone. The reduced-size solar zone is called the “designated” solar zone.

Exceptions for Reduced Solar Zone Due to Shade

Step 1: Determine the Annual Solar Access: For the solar ready requirements, solar access is the ratio of solar insolation including shading to the solar insolation without shading. Annual solar access is most easily determined using specialized software.

$$\text{Solar Access} = \frac{\text{Solar Insolation Including Shading}}{\text{Solar Insolation Without Shading}}$$

Solar access does not take into account shading from objects that are included in the building project because the designer has control of potential obstructions. Objects that are not part of the building project cannot be moved or modified as part of the project and include existing buildings, telephone poles, communication towers, trees, or other objects. Objects that are considered part of the building project are objects constructed as part of the building project and include the building itself, its HVAC equipment, outdoor lights, landscape features and other similar objects.

First evaluate whether there are any objects outside the building project that will shade the rooftop (or other prospective solar zone areas such as overhangs or parking shade structures). If an existing object is located north of all potential solar zones, the object will not shade the solar zone. Similarly, if the horizontal distance (“D”) from the object to the solar zone is at least two times the height difference (“H”) between the highest point of the object and the horizontal projection of the nearest point of the solar zone, then the object will not shade the solar zone (See Figure 7-4).

Step 2: Determine the Potential Solar Zone Area: On low-sloped roofs, the potential solar zone is the area where annual solar access is ≥ 70 percent.

On steep-sloped roofs the potential solar zone is the area where the annual solar access is ≥ 70 percent on the portion oriented between 90 and 300 degrees of true north.

Step 3: Determine the size of the designated solar zone. The designated solar zone must be ≥ 50 percent of the potential solar zone area. If the roof is shaded such that there is no potential solar zone area, then no solar zone is required. See Figure 7.1. Document the method/tools used to demonstrate that the solar access is less than 70 percent in the compliance form CF1R-SRA-02-E (Minimum Solar Zone Area Worksheet).

Example 7-13**Question:**

A house has a total roof area of 2,500 SF. The neighbor's house and trees shade the roof, so 2,100 SF of the roof has less than 70 percent annual solar access. How big does the solar zone have to be?

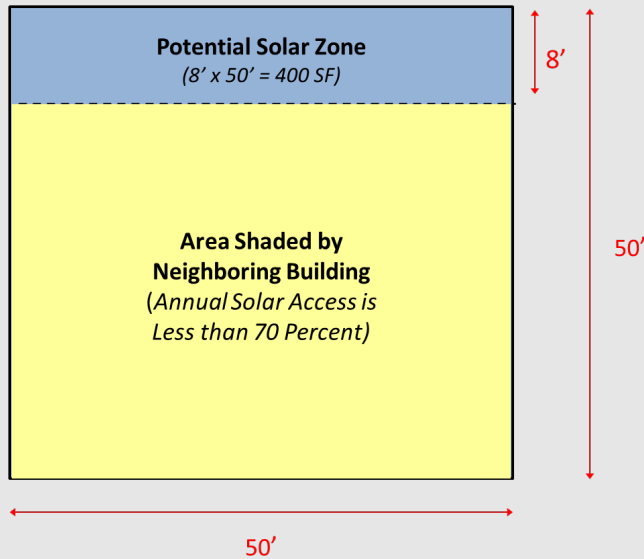
**Answer:**

If the entire roof were to have an annual solar access of 70 percent or greater, the minimum solar zone would have been 250 SF. Since the potential solar zone is only $2,500 - 2,100 = 400$ SF, however, the minimum solar zone can be reduced to 50 percent of the potential solar zone, or 200 SF.

Exception 5 allows a reduced solar zone of ≥ 150 square feet if all thermostats have demand responsive controls. See Appendix H of this compliance manual for guidance on compliance with the demand responsive control requirements.

Exception 6 allows no solar zone when the following energy efficiency features are installed:

All thermostats have demand responsive controls that comply with Section 110.12(a) and Joint Appendix JA5. (please see Exception 5, above, for more details). AND one of the following four measures (i – iv):

- i. Install a dishwasher that meets or exceeds the ENERGY STAR® program requirements with a refrigerator that meets or exceeds the ENERGY STAR program requirements, OR one of the followings:
 - a whole-house fan driven by an electronically commutated motor, OR

- an SAE J1772 Level 2 Electric Vehicle Supply Equipment (EVSE or EV Charger) with a minimum of 40 amperes. SAE J1772 is the SAE International document titled “SAE Electric Vehicle and Plug in Hybrid Electric Vehicle Conductive Charge Coupler” (SAE J1772_201710).
- ii. Install a home automation system that is capable of, at a minimum, controlling the appliances and lighting of the dwelling and responding to demand response signals; OR
- iii. Install alternative plumbing piping to permit the discharge from the clothes washer and all showers and bathtubs to be used for an irrigation system in compliance with the *California Plumbing Code*; OR
- iv. Install a rainwater catchment system designed to comply with the *California Plumbing Code* and uses rainwater flowing from at least 65% of the available roof area.

Example 7-14 Solar Ready Zone

Question:

What are the examples of how the solar ready zone requirements can be avoided using Exception 6?

Answer:

Exception 6 provides three options for avoiding the solar ready zone requirements altogether:

1. Install only demand responsive capable (DRC) thermostats with ENERGY STAR® dishwasher and refrigerator, or
2. Install only DRC thermostat(s) and a whole-house fan driven by an electronically commutated motor, or
3. Install only DRC thermostat(s) and a level 2 EV charger with a minimum of 40 amperes.

Any of these three options can be used to avoid the solar ready zone requirements.

Solar Zone Area for Low-Rise Multifamily Residential Buildings

The solar zone requirement for low-rise multifamily buildings is located in the 2019 Energy Standards with the requirements for high-rise multifamily, hotel/motel and nonresidential buildings in §110.10(b)1B. The solar zone requirement for low-rise multifamily buildings applies to mixed occupancy buildings as well.

The solar zone must be located on the roof or overhang of the building, or on the roof or overhang of another structure located within 250 feet of the building, or on covered parking installed with the building project. The solar zone's total area must be ≥ 15 percent of the building's total roof area. Subtract any skylight area when calculating the roof's total area.

Four solar zone exceptions apply to low-rise multifamily buildings in the 2019 Energy Standards. Exception 3 allows a smaller solar zone under certain circumstances. Exceptions 4 and 5 allow alternate efficiency measures in lieu of a solar zone. Therefore, the requirements for solar zone shading, azimuth and design load; interconnection pathway, and documentation do not apply.

Exceptions 1 and 2 do not apply to low-rise multifamily buildings.

Exception 3 reduces the solar zone area when the roof is shaded by objects that are not part of the building project, and therefore beyond the designer's control. The reduced-size solar zone is called the "designated" solar zone. The designated solar zone may be reduced to ≥ 50 percent of the potential solar zone area when solar access is limited. Solar access is the ratio of solar insolation including shade to amount of solar insolation without shade. Shading from obstructions on the roof or other parts of the building cannot be included to determine annual solar access.

See Figure 7-2 for more information about calculating the designated solar zone.

- Low-sloped roof: the potential solar zone area is the total area of any roof where annual solar access is 70% or greater.
- Steep-sloped roof: The potential solar zone area is the roof area where annual solar access is 70% or greater and oriented between 90 and 300 degrees of true north.

Exception 4 says multifamily residential buildings do not need a solar zone if all thermostats have demand responsive controls that comply with Section 110.12(a) and Joint Appendix JA5. See Exception 5 for single-family homes (above) for more thermostat details. In addition to the compliant thermostats, choose A or B below:

- A. One of the following four measures installed in each dwelling unit (i. – iv.):
 - i. Install a dishwasher that meets or exceeds the ENERGY STAR® program requirements with a refrigerator that meets or exceeds the ENERGY STAR program requirements, or a whole-house fan driven by an electronically commutated motor.
 - ii. Install a home automation system that complies with §110.12(a) and is capable of, at a minimum, controlling the appliances and lighting of the dwelling and responding to demand response signals; or
 - iii. Install alternative plumbing piping to permit the discharge from the clothes washer and all showers and bathtubs to be used for an irrigation system in compliance with the *California Plumbing Code*; or

- iv. Install a rainwater catchment system designed to comply with the *California Plumbing Code* and that uses rainwater flowing from at least 65 percent of the available roof area.

B. Meet the Title 24 Part 11, Section A4.106.8.2 requirements for electric vehicle charging spaces.

Exception 5 includes low-rise multifamily buildings and says a solar zone is not required when the roof is designed and approved to be used for vehicular traffic, or parking, or a heliport.

7.6.3 Azimuth (Solar Zone)

§110.10(b)2

For both single-family residential and low-rise multifamily buildings, all sections of the solar zone on steep-sloped roofs (ratio of rise to run of greater than 2:12) must be oriented between 90 degrees and 300 degrees of true north. The orientation is important because it ensures a reasonable solar exposure if a solar energy system is installed in the future. On a low-sloped roof (ratio of rise to run of 2:12 or less), the azimuth requirement does not apply.

Figure 7-4: Orientation when solar zone is located on a steep-sloped roof

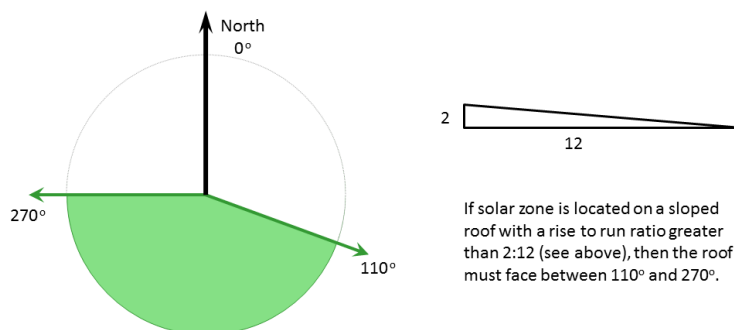

7.6.4 Shading (Solar Zone)

§110.10(b)3

For both single-family residential and low-rise multifamily buildings, the solar zone must be free from roof penetrations and shall not have any obstructions such as vents, chimneys, architectural features, or roof-mounted equipment located in the solar zone. This requirement ensures that the solar zone remains clear and open for the future installation of a solar energy system.

Any obstruction located on the roof or any other part of the building that projects above the solar zone must be located at a sufficient horizontal distance away from the solar zone in order to reduce the resulting shading of the solar zone. For each obstruction, the

horizontal distance (“D”) from the obstruction to the solar zone shall be at least two times the height difference (“H”) between the highest point of the obstruction and the horizontal projection of the nearest point of the solar zone.

$$\text{Shading Equation: } D \geq 2 \times H$$

Figure 7-5: Schematic of Allowable Setback of Rooftop Obstructions

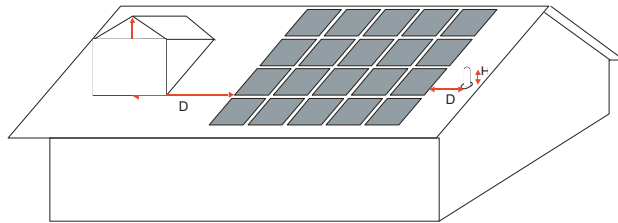

Source: California Energy Commission

Any obstruction oriented north of all points of the solar zone is not subject to the shading requirement. Any obstruction that is not located on the roof or another part of the building, such as landscaping or neighboring building, is not subject to the shading requirement.

7.6.5 Structural Design Loads (Solar Zone)

The structural design loads for roof dead load and roof live load must be clearly indicated on the construction documents for the designated solar zone areas. The structural load information will be easily available if the building owner considers a solar energy system installation in the future. It is not necessary to estimate the collateral loads for future solar energy systems.

The structural design loads requirement applies to the solar zone on both single-family residential and low-rise multifamily buildings.

7.6.6 Interconnection Pathways

§110.10(c)

All buildings that comply by designating a solar zone must also include a plan for connecting a future PV and SWH system to the building’s electrical or plumbing system. The construction documents must indicate:

1. A reserved location for inverters and metering equipment for solar electric systems.
2. A reserved conduit route from the solar zone to the point of interconnection with the electrical service. There is no requirement to install any conduit.

3. For single family residences, and multifamily buildings with a central water heating system, a reserved plumbing pathway from the solar zone to the water-heating system connection. There is no requirement to install any plumbing.

This requirement applies to both single-family residential and low-rise multifamily buildings.

7.6.7 Documentation

§110.10(d)

A copy of the construction documents or a document containing the required solar-ready information must be provided to the occupant. The building occupant must also receive a copy of compliance forms CF1R-SRA-01-E and CF1R-SRA-02-E. Providing this information to the building occupant is required so the information is available if the owner decides to install a solar energy system in the future. Construction documents must include information about the as-designed structural loads, solar zone location, and the reserved interconnection pathways. This requirement applies to both single-family residential and low-rise multifamily buildings.

7.6.8 Main Electrical Service Panel

§110.10(e)

This requirement applies only to single-family residential buildings. The main electrical service panel must have a minimum Busbar rating of 200 amps. The panel must also include space to install a double-pole circuit breaker in the future, if one is not installed during construction. These items are required to simplify the possible future installation of a solar electric system.

7.7 California Fire Code Solar Access Requirements

Under regulations established by the Office of the State Fire Marshal, the 2016 version of Parts 2, 2.5, and 9 of Title 24 include requirements for the installation of rooftop solar photovoltaic systems. These regulations cover the marking, location of DC conductors, and access and pathways for photovoltaic systems. They apply to residential and nonresidential buildings regulated by Title 24 of the California Building Standards Codes. Provided below is a brief summary of the fire code requirements for residential buildings. PV arrays shall not have dimensions in either axis greater than 150 feet. Residential buildings with hip, ridge/valley roof features shall provide a 3-foot access pathway away from applicable eave to hip/ridge/valley features. To provide adequate smoke ventilation, PV arrays shall not be located higher than 3 feet below the ridge. Builders shall refer directly to the relevant sections of Title 24 (most currently Part 2.5 Section R324.3, and Part 2.5 Section 324.7) for detailed requirements.

In addition to the requirements in the fire code, the California Department of Forestry and Fire Protection – Office of the State Fire Marshal (CAL FIRE-OSFM), local fire departments (FD), and the solar photovoltaic industry previously developed a *Solar Photovoltaic Installation Guideline* to increase public safety for all structures equipped with solar photovoltaic systems. The intent of this guideline is to provide the solar

photovoltaic industry with information that will aid in the designing, building, and installation of solar photovoltaic systems in a manner that should meet the objectives of both the solar photovoltaic industry and the requirements now set forth in the California Fire Code.

The entire Solar Photovoltaic Installation Guideline can be accessed at <http://osfm.fire.ca.gov/pdf/reports/solarphotovoltaicguideline.pdf>

Figure 7-6: The Following Illustrations Demonstrate Some Acceptable Solar Access Techniques.

Cross Gable Roof

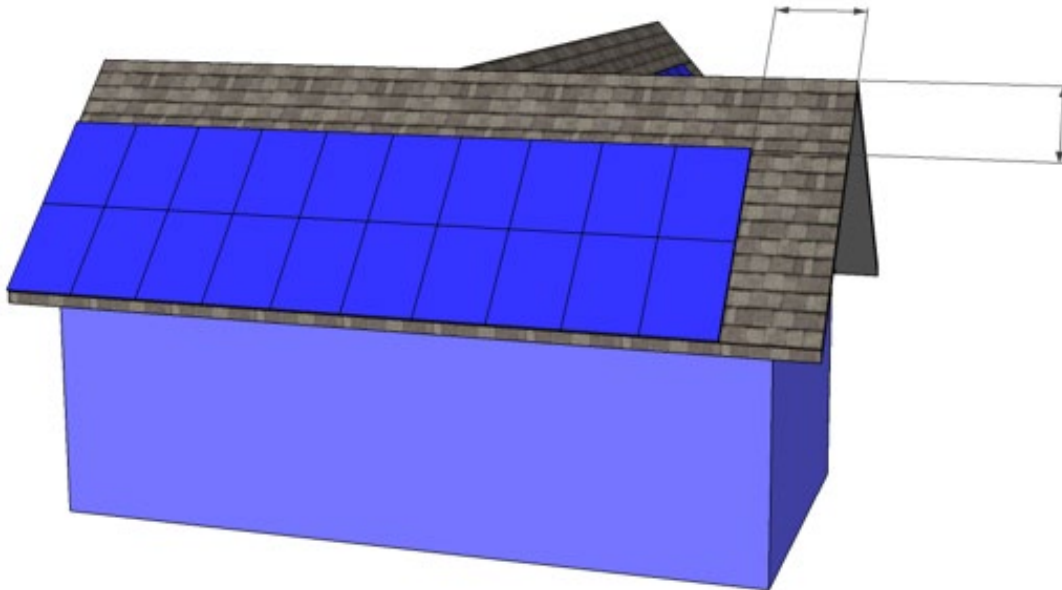

Cross Gable Roof with Valley

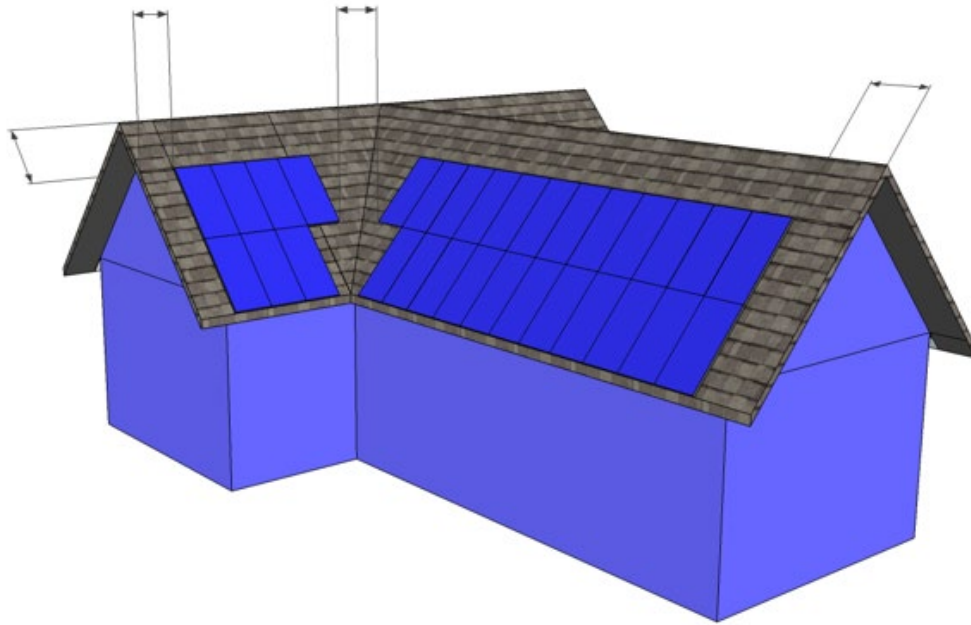

Full Gable Roof

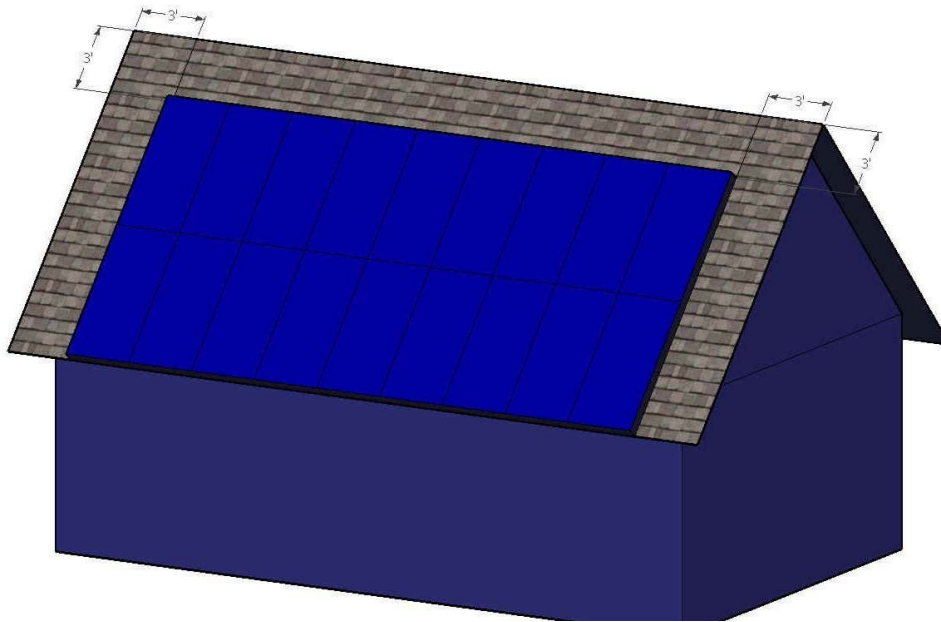

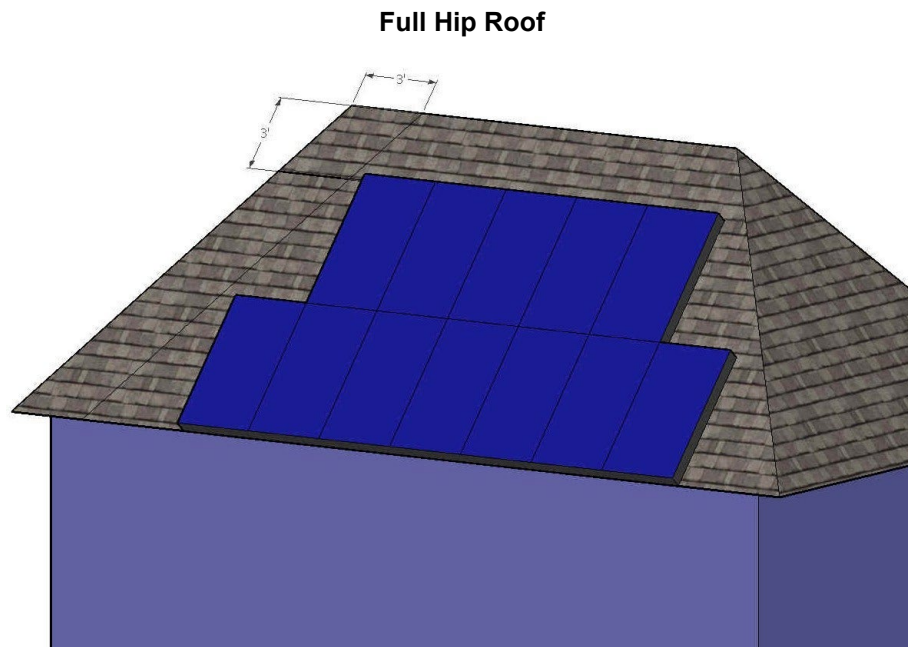

7.8 Compliance and Enforcement

When a building permit application is submitted to the enforcement agency, the applicant also submits plans and energy compliance documentation. This section describes the forms and procedures for documenting compliance with the solar ready requirements of the Energy Standards. The following discussion is addressed to the designer preparing construction and compliance documents, and to the enforcement agency plan checkers who are examining those documents for compliance with the Standards.

There are four forms associated with the low-rise residential solar-ready requirements. Each form is briefly described below.

1. **CF2R-SRA-01-E:** Certificate of Compliance: Residential Solar Ready Areas

This form is required for every project where the solar-ready requirements apply: newly constructed single-family residential and low-rise multifamily buildings.

2. **CF2R-SRA-02-E:** Certificate of Compliance: Minimum Solar Zone Area Worksheet

This form is required when buildings comply with the solar-ready requirement by including a solar zone. That is, an appropriately sized solar PV system is not installed, an appropriately sized solar water heating system is not installed, the building does not comply with all the OCST and high-efficacy lighting requirements or the roof is not designed for vehicle traffic or a heliport.

3. **CF2R-STH-01-E:** Certificate of Installation – Solar Water Heating System

Single Family Residential Only: This form is required when the building is using solar zone Exception 1 because a compliant solar water heating system has been installed on the home.

Table of Contents

8	Performance Method	1
8.1	Overview	1
8.2	What’s New for 2019.....	1
8.2.1	Determining Compliance – Energy Design Rating (EDR).....	1
8.2.2	Major Changes Affecting Standard Efficiency.....	2
8.2.3	New HERS Verification Requirements	2
8.3	Compliance Basics.....	3
8.3.1	Compliance Process.....	3
8.3.2	Defining the Standard Efficiency.....	4
8.3.3	Professional Judgment	5
8.4	Mixed-Occupancy Buildings	6
8.5	Buildings with Multiple Dwelling Units	7
8.6	Multifamily Buildings.....	7
8.6.1	Whole-Building Compliance Approach	7
8.6.2	Unit-by-Unit Compliance Approach – Fixed Orientation Alternative	8
8.6.3	Unit-By-Unit Compliance Approach – Multiple Orientation Alternative	10
8.7	Subdivisions and Master Plans	10
8.7.1	Individual Building Approach	10
8.7.2	Multiple Orientation Alternative: No Orientation Restrictions	11
8.8	HVAC Issues.....	12
8.8.1	No Cooling Installed	12
8.8.2	Wood Heat.....	12
8.8.3	Multiple HVAC Systems.....	12
8.8.4	HERS Verified Efficiency	12
8.8.5	Existing + Addition + Alteration Approach	12

8 Performance Method

8.1 Overview

This chapter explains the performance method of complying with the *2019 Building Energy Efficiency Standards* (Energy Standards). The method works by calculating an Energy Design Rating (EDR). The EDR is a score from 0 to 100, where 0 represents a building that has zero net energy consumption based on the time-dependent valuation ((TDV) energy consumption and 100 represents a building that is minimally compliant with the 2006 International Energy Conservation Code. This is the same criteria for a score of 100 for the National Home Energy Rating System (NatHERS). Approved programs calculate an EDR for the building (proposed efficiency) and compare it to the energy budget (standard efficiency). Approved compliance programs also calculate an EDR for proposed photovoltaic (PV)/demand flexibility and compare it to standard PV/flexibility budget.

The standard efficiency includes water heating, space heating, space cooling, indoor air quality (IAQ) fan energy, and solar generation. Energy use from lighting, kitchen appliances, and washers/dryers is not eligible to be traded off.

The Energy Commission approved computer programs for compliance calculate space-conditioning and water-heating energy use in accordance with a set of rules. Modeling capabilities are in the *2019 Residential ACM Reference Manual* (ACM Reference Manual). All software programs use the same compliance generation tool (California simulation engine [CSE]) to simulate the energy use, and the same report generator to create the certificate of compliance (CF1R), as the public domain program CBECC-Res. Vendors of approved software have the flexibility to create their own user interface, user documentation, and additional forms.

This method provides maximum flexibility to trade off the energy performance of different building components to achieve compliance. Making a building more efficient will lower utility bills and improve comfort.

The performance method is the most popular compliance method allowing builders the flexibility to optimize performance at the lowest cost. Each approved program is required to have a compliance supplement with information on the use of the software as specified in the *2019 ACM Approval Manual*.

A discussion of the performance method with additions and alterations is in Chapter 9.

8.2 What's New for 2019

8.2.1 Determining Compliance – Energy Design Rating (EDR)

The EDR has three components: 1. efficiency EDR, 2. PV/flexibility EDR, and 3. total EDR (also called final EDR). The efficiency EDR is based on the energy efficiency features of the building, including the envelope, HVAC, and hot water-heating features. The PV/flexibility EDR score captures the PV system, battery

storage system, precooling strategy, and other demand responsive measures. The total EDR combines the efficiency EDR and PV/Flexibility EDR into a final score. The approved programs do not allow installing more PVs in exchange for less efficiency. However, if PVs are coupled with a battery storage system, a modest credit known as the self-utilization credit is available for tradeoff against the efficiency features. Approved compliance programs allow installing more energy efficiency in exchange for a smaller PV system.

Compliance requires meeting two different criteria:

- Proposed efficiency EDR must be equal or less than standard efficiency EDR, and
- Total EDR (efficiency, PV, battery storage) must be equal or less than total standard EDR.

The efficiency EDR is the building's efficiency without any solar generation. The total EDR includes solar generation and any battery storage. This means the building must be energy efficient and it must generate enough energy to offset the electricity used to operate the building.

8.2.2 Major Changes Affecting Standard Efficiency

The standard design efficiency is based on prescriptive requirements. Two major changes to the standards are quality insulation installation (QII) and solar generation. Although not mandatory, performance compliance will be much more difficult to achieve without QII.

More information about the prescriptive solar electric generation Chapter 7 of this manual or the ACM Reference Manual.

8.2.3 New HERS Verification Requirements

Heat pumps will require verification of their capacity. Because the capacity affects the use of electric resistance back-up heating, a HERS Rater will verify the installed capacity meets or exceeds the capacities modeled for compliance. Software users can either enter the heat pump capacities (at both 47 and 17 degrees) or use an automatic sizing function. (Reference Appendix RA3.4.4.2.)

Whole house fans provide a significant compliance benefit in some climate zones. Software users will have three options, two of which require HERS Rater verification of airflow and watt draw: (1) specify a fan airflow, (2) select the default fan airflow required for prescriptive compliance with HERS verification, or (3) select the default fan airflow without HERS verification (the effectiveness of the whole house fan is derated by 7 percent). When verification is required, a HERS Rater will verify the watt draw and airflow rate. (Reference Appendix RA3.9.)

8.3 Compliance Basics

8.3.1 Compliance Process

Any approved computer program may be used to comply with the Energy Standards using the performance method. The following steps are an outline of the typical computer program procedure:

1. Collect all necessary data on each component.
 - a. For the building envelope, the area of each fenestration, wall, door, roof, ceiling and floor is needed. For each component, the applicable energy characteristics needs to be defined including U-factor, solar heat gain coefficients (SHGC), solar reflectance, and thermal mass values.
 - b. For HVAC systems, the type and efficiency of space conditioning equipment are required. For hydronic space heating, the specific water heater type and efficiency are required. For fan-forced conditioning systems, the location and amount of insulation of the duct system are needed.
 - c. For domestic hot water systems, the water heater type, quantity, efficiency, and area served will be required, along with the water-heating distribution system. Additional information will be required for features such as solar thermal systems and drain water heat recovery devices. More information is in Chapter 5.
 - d. For PV systems, the proposed size, and installation location information such as roof slope and orientation of the PV system are needed. Battery storage capacity and control information must be described if battery storage is proposed. Refer to Chapter 7 for more information.

Other efficiency measures and options can be used to improve building efficiency.

2. Enter the building envelope basic data such as square footage, number of stories, occupancy type, and climate zone. Define each opaque surface with the related orientation, area, and thermal performance properties. Add the fenestration associated with each opaque surface, including any fixed shading such as overhangs and side fins. Enter the data of the equipment and distribution systems for the space conditioning and water-heating systems. The input values and assumptions must correspond to the information on the final approved plan set and inputs must be equal to or more energy efficient than required mandatory measures.
3. Launch a computer simulation to calculate the efficiency EDR and total EDR of the standard design and the proposed design.

For additions and alterations, compliance is based on the TDV energy, and not the EDR criteria for newly constructed buildings. In existing buildings, where the values of installed features are unknown, default values may be used based on the year of the construction. Refer to Table 8-1, Default Assumption for Year Built, at the end of this chapter.

The building energy efficiency complies if all mandatory measures are met and the total TDV energy use of the proposed design is the same as or less than the standard design TDV energy budget.

When creating a computer input file, use the space provided for the project title information to concisely describe the building being modeled. User-designated names should be clear and internally consistent with other orientations and/or buildings being analyzed. Title names and explanatory comments should assist in the compliance and enforcement processes.

8.3.2 Defining the Standard Efficiency

Approved compliance software programs automatically calculate the standard efficiency based on data entered for the proposed building.

The computer program defines the standard building by modifying the geometry of the proposed building and inserting the features of Table 150.1-A (single family) or Table 150.1-B (multifamily) of the Energy Standards. Details are in the *2019 Residential ACM Reference Manual*.

Note the details of how the standard efficiency is determined. Deviations from the prescriptive requirements will be reflected in the compliance margin. For example, if the prescriptive requirements from Table 150.1-A or B include roof deck insulation in Option B for the applicable climate zone, and the proposed building is modeled without roof deck insulation, it will significantly affect the attic temperature and result in a compliance penalty. (In prescriptive compliance, a roof with no roof deck insulation would require ducts inside the conditioned space.) In 2019, the standard efficiency includes QII and solar generated electricity. Compliance will be much more difficult to achieve if either of these is not included in the proposed efficiency.

The standard design assumes the same total conditioned floor area and volume as the proposed design and the same gross exterior wall area as the proposed design except that the wall area in each of the four cardinal orientations is divided equally. The standard design uses the same roof/ceiling area, raised floor area, slab-on-grade area, and perimeter as the proposed design but uses the standard insulation R-values required in Table 150.1-A or 150.1-B of the Energy Standards.

The standard design includes all features of the prescriptive compliance tables, including QII, walls with the prescriptive U-factor, roofs with below deck insulation in many climate zones or radiant barrier in other climate zones, and a solar PV system.

Total fenestration area in the standard is equal to the proposed if the fenestration area in the proposed design is less than or equal to 20 percent of the floor area. Otherwise, the fenestration area is equal to 20 percent of the floor area.

Fenestration area in the standard is evenly distributed among the four cardinal orientations. SHGC and U-factors are the same as those listed in the prescriptive tables with no overhangs.

The standard design includes minimum efficiency heating and cooling equipment, as well as the minimum duct R-value required for Option B from Table 150.1-A or 150.1-B of the Energy Standards. Ducts are assumed to be sealed as required by

§150.0(m). The standard design also assumes correct refrigerant charge as required by §150.1(c)7A.

For water-heating systems that serve dwelling units, the standard design is an instantaneous gas storage water heater with an energy factor equal to the federal minimum standard. The distribution system meets all mandatory requirements specified in §150.0.

For multifamily buildings, when central water heating is proposed, the standard design is based on §150.1(c)8B, which includes details about the recirculation system and a minimum solar fraction that varies by climate zone. See the ACM Reference Manual for more information.

8.3.2.1 Standard Reports

For consistency and ease of enforcement, the manner in which building features are reported by compliance software programs is standardized. Energy Commission-approved compliance software programs produces compliance reports in a standard format. The principal report is the certificate of compliance (CF1R-PRF-01-E).

The CF1R-PRF-01 includes two sections, one for special features and modeling assumptions, and a second requires field verification and/or diagnostic testing by approved HERS Raters. These sections provide a general overview during compliance verification by the local enforcement agency and the HERS Rater. Items in the special features and modeling assumptions section indicate that if such features or assumptions used for compliance are not installed, the building would be noncompliant, and they call for special care by the local enforcement agency. Items in the HERS required verification section rely on diagnostic testing and independent verification by an approved HERS Rater to ensure proper field installation. Diagnostic testing and verification by HERS Raters is in addition to local enforcement agency inspections.

8.3.3 Professional Judgment

Some modeling techniques and compliance assumptions applied to the proposed design are fixed or restricted. At other times, professional judgment may be acceptable or necessary.

Enforcement agencies can reject a particular input if the permit applicant cannot substantiate the value with supporting documentation or cannot demonstrate that appropriate professional judgment was applied.

Two questions can resolve whether professional judgment was applied correctly:

- Is a simplified input or assumption appropriate and conservative? If simplification increases the predicted energy use of the proposed building or reduces the compliance margin when compared to a more explicit and detailed modeling assumption, the simplification is acceptable. Simplification must reflect a worse case than a more detailed model and result in the same or lower compliance margin.

- Is the approach or assumption consistent with what is used by the compliance software to generate the standard design?

Any unusual modeling approach, assumption, or input value should be documented with published data and conform to standard engineering practice.

Call the Energy Hotline or contact the compliance software vendor for help in evaluating the appropriateness of input assumptions.

Example 8-1

Question

Three different-sized windows in the same wall of a new home are designed without exterior shading. They have the same National Fenestration Rating Council (NFRC) rated U-factors and SHGC values. Is it acceptable professional judgment to simplify the computer model by adding the areas of the windows and inputting them as a single fenestration area?

Answer

No. Although the compliance software will produce the same results whether the windows are modeled individually or together as one area, plan checking or finding errors when windows are combined is much more difficult. If the software has a multiplier, identical window sizes with identical shading features can be combined. Otherwise each window is modeled individually.

8.4 Mixed-Occupancy Buildings

§100.0(f)

Some residential buildings have areas of other occupancies, such as retail or office, in the same building. An example is a three-story building with two floors of apartments above ground-floor shops and offices. Consider the number of habitable stories in the building. If there are four or more stories, high-rise residential standards apply to any residential occupancies.

Depending on the area of the different occupancies, energy compliance may be demonstrated as if the whole building is residential for the space-conditioning and water-heating requirements. This is allowed if the residential occupancy accounts for at least 80 percent of the conditioned floor area of the building (or permitted space). Lighting compliance must be based on the requirements for each occupancy type.

Note: Mandatory measures apply separately to each occupancy type regardless of the compliance approach used. The residential envelope is subject to §150.0, while the nonresidential envelope is subject to §120.7.

If complying under the mixed-occupancy exception, residential and nonresidential documentation for mandatory measures must be submitted with other compliance documentation.

If the building design does not fit the criteria for a dominant occupancy, then the low-rise residential occupancy type must be shown to comply by itself. The remaining

occupancy types must be shown to comply separately either by independent compliance for each occupancy or for the nonresidential performance approach by combining nonresidential occupancies in accordance with the *Nonresidential ACM Reference Manual*. This may be done by using any approved prescriptive or performance methods available for each occupancy type. Documentation for each occupancy type must also be considered separately, and a certificate of compliance must be submitted for each occupancy type. Mixed high-rise and low-rise residential occupancies will not occur in the same building because the designation applies to the building.

8.5 Buildings with Multiple Dwelling Units

There are three classifications of multiple dwelling unit buildings:

- Buildings with two dwelling units (duplexes): Each dwelling unit is modeled as an individual single family building.
- Buildings consisting of townhouse style dwelling units. These have no common ceilings or floors between dwelling units. Each dwelling unit is modeled as an individual single family building.
- Buildings consisting of three or more dwelling units that are not townhouses (R-2 occupancy group). Model as a multifamily building.

8.6 Multifamily Buildings

§100.1(b)

Envelope, HVAC equipment, and outdoor lighting requirements for high-rise multifamily buildings (four or more habitable stories) are covered by the *Nonresidential Energy Standards*. These requirements are in the *Nonresidential Compliance Manual*. Indoor lighting in dwelling units and water-heating requirements for high-rise multifamily buildings are covered under the *Residential Energy Standards* and this manual.

Low-rise multifamily buildings (occupancy group R-1 or R-2) that are one to three habitable stories are covered by the *Residential Energy Standards* and this manual. Compliance for a low-rise multifamily building may be demonstrated either for the building as a whole or on a unit-by-unit basis. Rental apartment buildings are usually modeled as a whole building. For multifamily buildings designed for dwelling units to be owner-occupied, the project developer may favor providing a separate, unique energy compliance report for each dwelling unit. Floors and walls between dwelling units are considered to have no heat transfer and are treated as interior surfaces in performance calculations.

8.6.1 Whole-Building Compliance Approach

The simplest compliance for a multifamily building is treating the building as a whole, using the compliance paths described earlier. This is similar to analyzing a single-family residential building, except for differences described in the *2019 Residential ACM Reference Manual*.

Multifamily buildings that use efficiency measures that require HERS field verification must submit separate compliance documentation for each dwelling unit in the building as specified by Reference Residential Appendix RA2.3. This requirement does not prevent using the whole-building compliance approach to submit the certificate of compliance to the enforcement agency. For measures that requires HERS verification, a relationship to the whole-building certificate of compliance is made for the corresponding certificates of installation, and the dwelling-specific certificates of verification. Thus, for the whole-building compliance approach in a multifamily building the required energy compliance documentation for each dwelling unit should consist of a whole-building certificate of compliance (CF1R-PRF-01), a dwelling-specific certificate of installation (CF2R), and a dwelling-specific certificate of verification (CF3R).

When the whole-building compliance approach is used for a multifamily building, some of the energy efficiency measures that require HERS field verification cannot be used for compliance credit in the performance calculations. These HERS measures are excluded from the whole-building compliance approach because they require dwelling-specific data input into the compliance software.

The measures that cannot be used for the multifamily whole-building compliance approach, but can be used for credit when dwelling units are individually modeled, include:

- Buried ducts credit.
- Deeply buried ducts credit.
- Reduced supply duct surface area credit.
- Building envelope sealing credit (blower door test).

When the Energy Standards require registration of the compliance documents, the information for the certificate of compliance (CF1R), certificate of installation (CF2R), and certificate of verification (CF3R) must be submitted electronically to the HERS registry. Refer to Reference Residential Appendix RA2.3 for more about these document registration procedures.

8.6.2 Unit-by-Unit Compliance Approach – Fixed Orientation Alternative

The unit-by-unit compliance approach for multifamily buildings requires that each dwelling unit must demonstrate compliance separately. The fixed orientation alternative requires that each unique dwelling unit in the building, as determined by orientation and floor level, must be separately modeled using an approved compliance program. Surfaces that provide separation between dwelling units are treated as interior surfaces and are assumed to have no heat loss or heat gain. Surfaces that provide separation between dwelling units and central/interior corridor areas must be modeled if the corridor area is not directly conditioned or indirectly conditioned space. (See Reference Joint Appendix JA1 for definition.) If the corridor area is conditioned, the corridor area may be modeled separately.

Different orientations and locations of each unit type within the building must be considered separately. A one-bedroom apartment on the ground floor of a three-story building is different from the same plan on a middle floor or the top floor, even if all apartments have the same orientation and are otherwise identical. End units

must be modeled separately from the middle units, and opposite end units must also be modeled separately. Every unit of the building must comply with the Energy Standards, so this unit-by-unit approach is more stringent than modeling the building as a whole (See Figure 8-1).

Figure 8-1: Multifamily Building Compliance Option

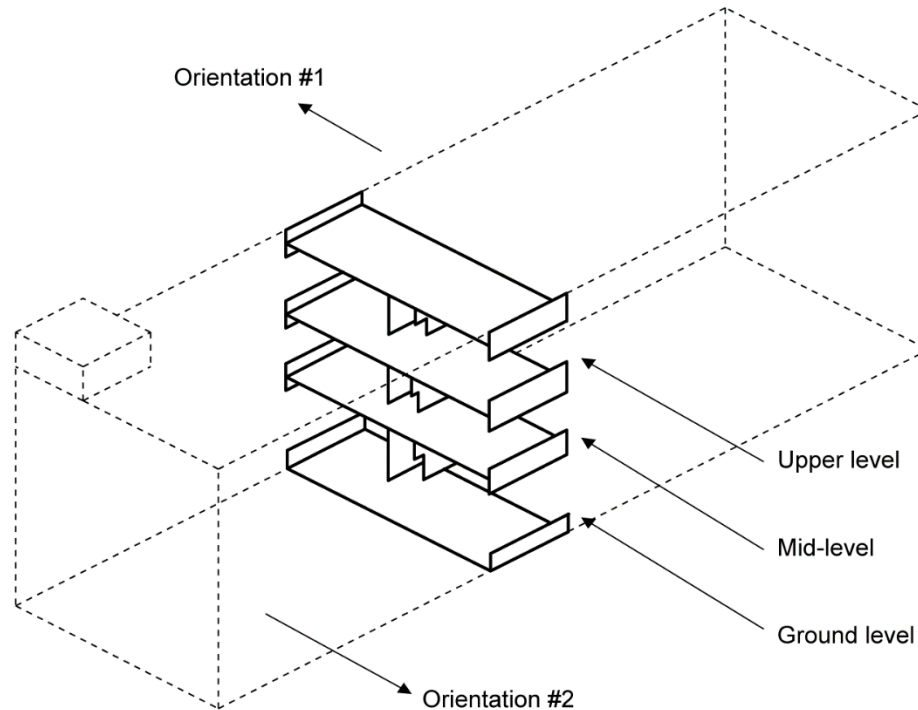

Demonstrate Compliance for Each Generic Unit Type in Each of its Characteristic Locations

Source: California Energy Commission

Example 8-2

Question

When preparing compliance calculations for a three-story apartment complex, I can show compliance for each dwelling unit or for the entire building. Are calculations for every dwelling unit needed if the individual dwelling unit approach is used?

Answer

No. When dwelling units have identical conditions, the calculations can be combined. Show separate compliance for all unique conditions, such as:

- Front-facing north.
- Front-facing west.
- Front/side walls facing east and north.
- Front/side walls facing east and south.
- Middle units and both end units.

- Exterior roof, no exterior floor.
- Exterior floor, no exterior roof.

Surfaces separating two conditioned spaces (such as common walls) are modeled as interior surfaces.

Note: For multiple dwelling units that are identical except orientation, a single multiple orientation report can be used to demonstrate compliance. (See Section 8.7.2 below.)

8.6.3 Unit-By-Unit Compliance Approach – Multiple Orientation Alternative

Another option for unit-by-unit compliance for a multifamily building is the multiple orientation alternative. This is similar to the method that may be used for single-family master plans in subdivisions (described in Section 8.7).

The performance method may be used to demonstrate that a dwelling unit plan in a multifamily building complies regardless of orientation. To ensure compliance in any orientation, the annual energy consumption must be calculated with cardinal orientation (a combined CF1R with results for north, east, south, and west). With this option, a dwelling unit plan must be modeled using the identical combination of energy features and must comply with the energy budget in each orientation. Cardinal compliance can be used to show compliance for a reversed floor plan.

Each unique dwelling unit plan must be modeled using the worst-case condition for the energy features that the plan may contain within the building (for example, highest glazing percentage, least overhangs, largest wall surface area, and with exterior walls instead of party walls, if applicable). See Reference Residential Appendix RA 2.6.2 for information that describes how to determine when a dwelling is a unique model. Each unique dwelling plan must also be modeled separately for each floor level.

8.7 Subdivisions and Master Plans

Subdivisions often require a special approach to energy compliance because they have one or a few basic building or unit plans repeated in a variety of orientations. The basic floor plans may also be used in a mirror image or reversed configuration.

The two compliance options for subdivisions are the following:

- Model each individual building, or building condition, separately according to the actual orientation.
- Model all four cardinal orientations for each building or plan type with identical conservation features for no orientation restrictions.

8.7.1 Individual Building Approach

The most straightforward option for subdivisions is analyzing each building in the project separately using any compliance method. This may be practical for subdivisions with only custom buildings, or with only one or two specific orientations for each building plan. This approach requires that each unit comply separately, with separate documentation submitted for each unit plan in the orientation in which it will be constructed.

8.7.2 Multiple Orientation Alternative: No Orientation Restrictions

§150.1(b)

The performance method may be used to demonstrate that a single-family dwelling plan complies regardless of its orientation within the same climate zone. To ensure compliance in any orientation, the annual energy consumption must be calculated using cardinal orientation (a single CF1R with results for north, east, south, and west). The buildings must have the identical efficiency measures and levels and comply with the energy budget in orientation. Cardinal compliance can be used to show compliance for a reversed floor plan.

Figure 8-2: Subdivisions and Master Plans Compliance Option

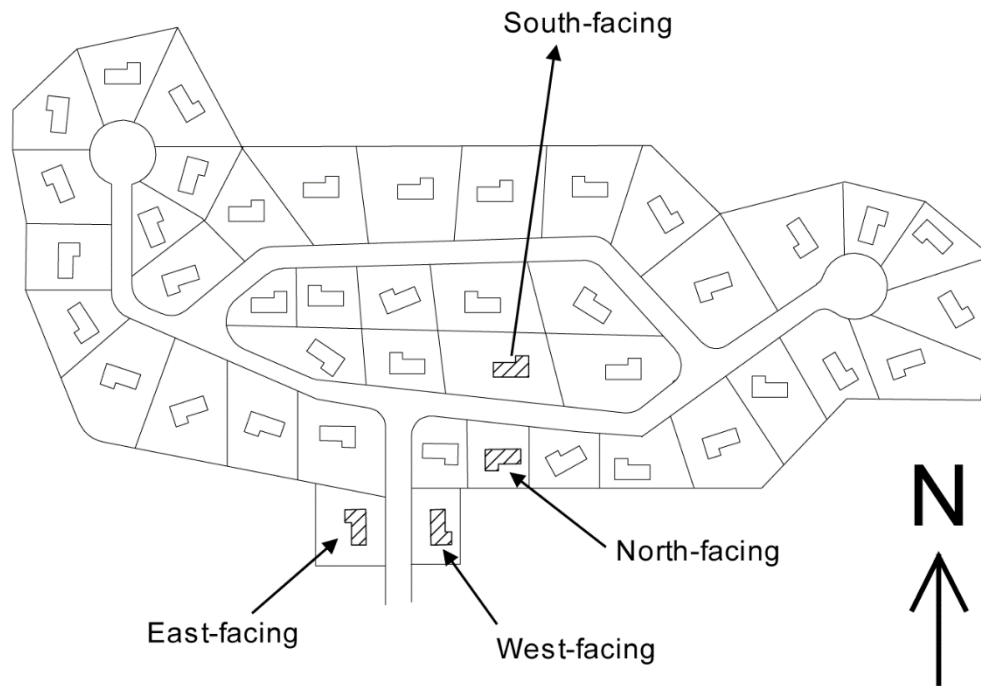

Demonstrate Compliance for Each Cardinal Orientation for Each Basic Model Type

Source: California Energy Commission

For compliance, submit certificate of compliance documentation of the energy budgets for each of the four orientations to the enforcement agency. Only one CF1R form that documents compliance for all four orientations is required to be submitted to the enforcement agency for each unique or reverse plan.

Master plans that use the multiple orientation alternative must establish a connection to the CF1R in the HERS registry. For the multiple orientation compliance approach in a master plan subdivision, the required documentation for each dwelling unit should be a multiple orientation master plan certificate of compliance (CF1R), a dwelling-specific installation certificate (CF2R), and a dwelling-specific certificate of verification (CF3R).

8.8 HVAC Issues

8.8.1 No Cooling Installed

When a building has no cooling system, the software simulates a hypothetical system with the characteristics required by Table 150.1-A or B if a cooling system was installed. The result is neither a penalty nor a credit.

8.8.2 Wood Heat

When natural gas is not available, and all other eligibility criteria are met (see Chapter 4), a wood heating system is simulated as a hypothetical system with the characteristics required by Table 150.1-A or B for a typical heating system. When all eligibility criteria are met, the backup system is not modeled, otherwise see Section 8.8.3.

8.8.3 Multiple HVAC Systems

Buildings with multiple HVAC systems are treated as follows:

1. For buildings with more than one system type, equipment type, or fuel type, where the types do not serve the same floor area, model the building zone or floor area served by each unique type separately.
2. Supplemental heating may be ignored if two criteria are met: (1) If the capacity of the supplemental unit does not exceed 2 kilowatts (kW), or 7,000 British thermal units per hour (Btu/h), and (2) if the supplemental unit is controlled by a time-limiting device not exceeding 30 minutes. (§150.1(c)6.)

In a building with an appliance rated gas fireplace and a central gas furnace, the furnace is the primary system and the fireplace is the supplemental system. The controls for the fireplace would not need to meet the setback thermostat requirements (exception to §110.2(c)).

3. For redundant equipment, where the floor area is served by more than one heating or cooling system, equipment type, or fuel type, model the least efficient system. For any areas served by electric resistance heat and another heating system (except for wood heating meeting all eligibility criteria), the electric resistance system is the least efficient system.

When there is more than one system meeting the heating or cooling load for the same space, all systems must still meet all the mandatory requirements of the Energy Standards.

8.8.4 HERS Verified Efficiency

When higher than minimum efficiency is modeled, a HERS Rater must verify the efficiency. This includes seasonal energy efficiency ratio (SEER), energy efficiency ratio EER, and heating seasonal performance factor (HSPF).

8.8.5 Existing + Addition + Alteration Approach

The performance approach may be used to show compliance for alterations in existing buildings, new additions, and existing + addition + alteration discussed in

Chapter 9. The following table can be used when existing conditions are unknown. The table is based on the year of the building construction.

Table 8-1: Default Assumptions for Year Built (Vintage)

Conservation Measure	Before 1978	1978 to 1983	1984 to 1991	1992 to 1998	1999 to 2000	2001 to 2003	2004 to 2005	2006 to 2013	2014 to Present
INSULATION U-FACTOR									
Cool Roof	0.10	0.10	0.10	0.10	0.10	0.10	0.10	Table 150.1-A or B	Table 150.1-A or B
Radiant Barrier	None	None	None	None	None	None	None	Table 150.1-A or B	Table 150.1-A or B
Roof/Ceiling	0.079	0.049	0.049	0.049	0.049	0.049	0.049	0.049	0.031
Wall	0.356	0.110	0.110	0.102	0.102	0.102	0.102	0.102	0.102
Raised Floor – Crawl Space	0.099	0.099	0.099	0.049	0.049	0.049	0.049	0.049	0.037
Raised Floor-No Crawl Space	0.238	0.238	0.238	0.064	0.064	0.064	0.064	0.064	0.049
Slab Edge F-factor	0.73	0.73	0.73	0.73	0.73	0.73	0.73	0.73	0.73
Ducts	R-2.1	R-2.1	R-2.1	R-4.2	R-4.2	R-4.2	R-4.2	Table 150.1-A or B	Table 150.1-A or B
LEAKAGE									
Building (ACH50)	7.7	7.7	7.7	7.7	7.7	7.7	7.7	6.8	5.0
Duct Leakage (%)	15%	15%	15%	15%	15%	15%	15%	15%	6%
FENESTRATION									
U-factor	Use Energy Standards Table 110.6-A , §110.6 for all vintages.								
SHGC	Use Energy Standards Table 110.6-B , §110.6 for all vintages.								
Shading Devices	Exterior: Assumed to have 50% bug screens, model actual overhangs.								
SPACE HEATING EFFICIENCY									
Gas Furnace (Central) AFUE	0.75	0.78	0.78	0.78	0.78	0.78	0.78	0.78	0.78
Gas Heater (Room) AFUE	0.65	0.65	0.65	0.65	0.65	0.65	0.65	0.65	0.65
Hydronic/Comb Hydronic	0.78	0.78	0.78	0.78	0.78	0.78	0.78	0.78	0.78
Heat Pump HSPF	5.6	5.6	6.6	6.6	6.8	6.8	6.8	7.4	7.7
Electric Resistance HSPF	3.413	3.413	3.413	3.413	3.413	3.413	3.413	3.413	3.413
Electric Resistance Radiant HSPF	3.55	3.55	3.55	3.55	3.55	3.55	3.55	3.55	3.413
SPACE COOLING EFFICIENCY									
All Types, SEER	8.0	8.0	8.9	9.7	9.7	9.7	9.7	13.0	13.0
WATER HEATING									
Energy Factor	0.525	0.525	0.525	0.525	0.575	0.575	0.575	0.575	0.575

Table of Contents

9	Additions, Alterations, and Repairs	1
9.1	Introduction	1
9.1.1	Additions.....	1
9.1.2	Alterations.....	2
9.1.3	Repairs	3
9.2	What’s New in the 2019 Energy Standards.....	5
9.2.1	Mandatory Envelope.....	5
9.2.2	Mandatory Mechanical Ventilation.....	6
9.2.3	Prescriptive Additions	6
9.3	Compliance Approaches	6
9.3.1	Additions.....	7
9.3.2	Additions and Alterations Combined.....	8
9.3.3	Alterations Only	9
9.3.4	Wall Exceptions to Continuous Insulation.....	9
9.3.5	Accessory Dwelling Units (ADUs).....	10
9.4	Prescriptive and Mandatory Measures	13
9.4.1	Prescriptive Additions	16
9.4.2	Water Heating System.....	23
9.4.3	Alterations – Prescriptive/Mandatory Requirements	23
9.4.4	Envelope Alterations.....	24
9.4.5	Water Heating Alterations.....	35
9.4.6	HVAC System Alterations.....	37
9.4.7	Mechanical Ventilation.....	44
9.4.8	Lighting Measures	44
9.5	Performance Approach	46
9.5.1	Performance: Addition Alone	46
9.5.2	Performance Method: Additions and Existing + Addition + Alterations Approach	46
9.5.3	Existing + Addition + Alterations Without Third-Party Verification.....	48
9.5.4	Existing + Addition + Alterations With Third-Party Verification.....	49
9.5.5	Existing + Addition + Alterations as New Construction	49
9.5.6	Summary of Modeling Rules.....	49

9 Additions, Alterations, and Repairs

9.1 Introduction

This chapter covers key aspects of how the *2019 Building Energy Efficiency Standards* (Energy Standards) apply to construction of residential additions, alterations to an existing residential building, or both. As explained below, the Energy Standards do not apply to repairs.

The chapter is organized as follows:

1. **Section 9.1 – Introduction.** Highlights the applicable standards definitions for additions, alterations, and repairs and provides several examples of each.
2. **Section 9.2 – What’s New in the 2019 Energy Standards.** Highlights of the requirements and compliance options in the 2019 Energy Standards.
3. **Section 9.3 – Compliance Approaches.** An overview of prescriptive and performance compliance options.
4. **Section 9.4 – Prescriptive Approach.** Detailed information on prescriptive compliance methods for additions.
5. **Section 9.5 – Performance Method.** An explanation of computer compliance approaches for additions, including existing + addition + alterations.
6. **Section 9.7 – Alterations.** Detailed information on prescriptive and performance compliance methods.
7. **Section 9.8 – Mandatory Requirements.** Mandatory requirements for additions and alterations.

When additions and alterations include changes to the envelope, mechanical systems, and/or water heating systems, a certificate of compliance must be completed prescriptively or be generated by compliance software with the performance approach. The prescriptive certificate of compliance is the CF1R-ADD-01 or CF1R-ALT-02 form. (See Appendix A for a full list of forms.)

Changes to the HVAC systems will likely include one or more measures that require Home Energy Rating System (HERS) diagnostic testing and field verification. If a HERS measure is required, the certificate of compliance must be completed and registered online with an approved HERS provider using the provider’s web-site. Refer to Chapter 2 for information about document registration and to Residential Appendix RA2 for more information about HERS measures.

For copies of the appropriate compliance documentation, refer to Appendix A of this manual.

9.1.1 Additions

An *addition* is any change to an existing building that increases conditioned floor area and conditioned volume (including conditioning a previously unconditioned space). See §100.1.

Examples of an addition include:

1. Adding a conditioned sunroom or other rooms to an existing house.
2. Converting a garage or other existing unheated space into conditioned living space.
3. Enclosing and conditioning an existing patio area.
4. Obtaining a permit to legalize an existing, habitable, and conditioned space that was added to a residential dwelling without a permit.
5. Adding a bay window that extends to the floor, thereby increasing both floor area and volume.

9.1.2 Alterations

An *alteration* is any change to a water-heating system, space-conditioning system, lighting system, or envelope of a building that is not an addition. See § 100.1.

Examples of alterations include:

1. Adding insulation to any existing exterior roof or ceiling, exterior wall, or raised floor over a crawl space, garage, or unheated basement.
2. Replacing or installing a new top surface to an existing roof (reroofing) and replacing portions of or the entire roof assembly.
3. Replacing existing fenestration or adding fenestration area (for example, windows, bay windows, greenhouse/garden windows, dynamic glazing, clerestories, or glass doors) to existing walls.
4. Replacing an existing skylight or increasing the area of skylight to an existing roof.
5. Constructing an entirely new roof over an existing conditioned space.
6. Adding a loft within the existing conditioned volume of a home.
7. Replacing an existing heating system or adding a heating system (for example, a furnace, wall heater, heat pump, or radiant floor). (NOTE: Adding heating to a previously unconditioned space is an addition, not an alteration.)
8. Replacing an existing cooling system or adding a cooling system (for example, an air conditioner or heat pump).
9. Extending or replacing an existing duct system or adding an entirely new duct system.
10. Replacing the existing water heater or adding water heaters and/or hot water piping.
11. Replacing existing lighting or adding new hardwired lighting fixtures.
12. Adding window film.

9.1.3 Repairs

A *repair* is “the reconstruction or renewal for the purpose of maintenance of any component, system, or equipment of an existing building. Repairs shall not increase the pre-existing energy consumption of the repaired component, system, or equipment. Replacement of any component, system, or equipment for which there are requirements in the Energy Standards is considered an alteration and not a repair.” (See §100.1).

Note: Repairs to residential buildings are not within the scope of the Energy Standards.

For example, when a component, system, or equipment of an existing building breaks or is malfunctioning and maintenance fixes are needed for it to work properly again, it is considered a repair and not subject to the standards. However, if instead of fixing the break or malfunction, the component, system, or equipment is replaced with a new or different one, the scope of work is considered an alteration and not a repair and requirements of the Energy Standards must be met.

Examples of work considered repairs include:

1. Replacing a broken pane of glass but not the entire window.
2. Removing fenestration and other envelope components for maintenance or repair and then reinstalling the same fenestration or other envelope components in the same location.
3. Replacing a failed fan motor or gas valve in a furnace but not replacing the entire furnace.
4. Replacing a heating element in a water heater but not replacing the entire water heater.

Note: When any existing envelope component is moved to a new location, even when that location partially overlaps the previous location of the item, the work is considered an alteration.

Note 2: Replacement of some HVAC components for repair are defined by the Energy Standards as alterations, therefore triggering requirements that must be met. Section 150.2(b)1E of the Energy Standards defines the following HVAC component replacements as an alteration that triggers the requirement for duct sealing: *“replacement of the air handler, outdoor condensing unit of a split system air conditioner or heat pump, or cooling or heating coil.”* Similarly, if more than 40 linear feet of new or replacement space conditioning ducts are installed, then the entire duct system must be sealed and leakage tested to be equal or less than 15 percent. (See §150.2 (b)1D.)

Note 3: Some cooling system component replacements are defined by the Energy Standards as alterations, which require meeting certain requirements. Section 150.2(b)1F of the Energy Standards defines installing or replacing a compressor, condensing or evaporator coil, refrigerant metering device, or refrigerant piping as an alteration, which triggers several requirements, including thermostat and, depending on the climate zone, airflow, and refrigerant charge requirements. (See §150.2 (b)1F.)

Example 9-1**Question:**

A sunspace addition is designed with no mechanical heating or cooling and a glass sliding door separating it from all existing conditioned space. This design is approved by the enforcement agency as nonhabitable or unimproved space. Under what conditions will the Energy Standards apply to this addition?



Unconditioned Sunspace

Answer:

The mechanical and envelope requirements of the Energy Standards do not apply if the space is not considered habitable or improved and, therefore, can be unconditioned as defined in §100.1; however, per §100.0(c)2, the sunspace must still comply with the applicable lighting requirements of §150.0(k). The sunspace is unconditioned if:

- The new space is not provided with heating or cooling (or supply ducts).
- All openings between the new space and the existing house can be closed off with weatherstripped doors and windows.
- The addition is not indirectly conditioned space (defined in §100.1 under **CONDITIONED SPACE, INDIRECTLY**).

A building official may require a sunspace to be conditioned if it appears to be habitable space, in which case the Energy Standards apply.

Example 9-2**Question:**

An existing duplex is remodeled, which includes only the installation of new faucets and bathroom lighting. Do the Energy Standards apply?

Answer:

Yes, this remodel is considered an alteration. However, due to the limited scope of work and since no new conditioned space is being created, the remodel must comply only with the applicable mandatory measures described in §110.1 for appliances and §150.0(k) for residential lighting.

Example 9-3

Question:

An existing house is remodeled by adding floor area but not increasing the volume of the house (adding a loft in an area in the house with a vaulted ceiling). As part of this remodel, some windows are replaced, and two windows are being added. Several exterior walls are being opened up to install new wiring. What requirements will apply?

Answer:

Since floor area is added but not conditioned volume, this is an alteration and not an addition. It needs to comply with the Energy Standards using either the prescriptive or performance method, as well as meet all the applicable mandatory measures. To comply prescriptively, the new and replacement windows must meet the maximum U-factor and Solar Heat Gain Coefficient (SHGC) requirements of §150.2(b)1A and B. (If needed, area-weighted averaging may be used to meet these requirements.) Newly installed and replacement windows must also comply with the mandatory measures for caulking/sealing around windows per §110.7. In alterations, it is recommended to install insulation in the exposed walls if no insulation is found when walls are opened; for 2x4 wood framing install the mandatory minimum R-13 and for 2x6 wood framing install R-20.

Alternatively, the performance approach may be used to demonstrate compliance for the entire house, even if individual windows fail to meet the prescriptive requirements, as long as the building meets all applicable mandatory requirements. At this time, since the exterior walls are exposed or open, this allows the opportunity to insulate the walls and contribute the energy efficiency of the building. Such upgrades are unlikely to contribute to the compliance of the building without third party verification of existing conditions.

9.2 What's New in the 2019 Energy Standards

The 2019 Energy Standards include new mandatory measures and different compliance requirements for additions and alterations. This section highlights the key changes from the 2016 Energy Standards. Prescriptive compliance requirements may be higher than mandatory requirements.

9.2.1 Mandatory Envelope

Walls with 2x6 insulation have a mandatory insulation requirement of R-20 or U-0.071 (§150.1(c)2).

New masonry walls are required to be insulated to levels required in Table 150.1-A or 150.1-B (see Chapter 3) (§150.0(c)5).

9.2.2 Mandatory Mechanical Ventilation

When an addition to an existing building adds a new dwelling unit, indoor air quality requirements of §150.0(o) apply to the new dwelling unit. This includes accessory dwelling units (§150.2(a)1Cii).

9.2.3 Prescriptive Additions

1. Additions greater than 700 square feet must meet quality insulation installation (QII) requirements (§150.1(c)1E).
2. Additions 700 square feet or less:
 - a. Ceiling insulation in an attic shall meet R-38 in Climate Zones 1 and 11-16 and R-30 in Climate Zones 2-10.
 - b. Radiant barrier must be installed in Climate Zones 2-15.
3. Existing wood-framed walls with siding (or cladding) that will not be removed require only cavity insulation of R-15 in a 2x4 wall or R-21 in a 2x6 wall. (Continuous insulation is not required.)

See Section 9.3.4 for more information about wall extensions and exceptions to continuous insulation requirements.

9.3 Compliance Approaches

Apart from meeting all applicable mandatory requirements (Section 9.4), additions and alterations must demonstrate compliance using a prescriptive or performance method.

There are several compliance paths depending on the scope of work:

1. **Addition only**, where no changes are made to the existing building except removal of roofs, exterior walls/fenestration, and floors required as a result of the addition.
2. **Alterations only**, where there is no addition (that is, no increase in conditioned floor area and volume or adding conditioning to a previously unconditioned space).
3. **Addition and alterations**, where there are both additions and alterations to the existing building.

For each of these permit scenarios, Table 9-1 summarizes the available compliance approaches for low-rise residential additions and alterations.

Table 9-1: Compliance Alternatives for Residential Additions and Alterations

Project Scope	Prescriptive Approach	Performance Approach ¹
1. Alteration only:	Meet all applicable requirements for prescriptive alterations	Existing + Alterations without third party verification of existing conditions; or
		Existing + Alterations with third party verification of existing conditions; or
		Existing + Alterations as all new construction
2. Addition only:	Additions ≤400 ft ² ; or	Addition Alone
	Additions >400 ft ² and ≤700 ft ² ; or	
	Additions >700 ft ²	
3. Addition and existing combined (with or without alteration):	Meet all applicable requirements for prescriptive alterations (if any) and a prescriptive addition approach (see additions only above)	Existing + Addition + Alterations without third-party verification of existing conditions; or
		Existing + Addition + Alterations with third-party verification of existing conditions; or
		Existing + Addition + Alterations as all new construction
1) In the performance method, the building must be modeled with Energy Commission-approved compliance software, as explained in Chapter 8 of this manual.		

9.3.1 Additions

Regardless of compliance approach selected, the following exceptions apply:

1. **Additions of ≤ 300 ft²** do not require a cool roof product (if required by §150.1(c)11) to be installed.
2. **Whole-house fan (or ventilation cooling)** does not apply to additions of 1,000 ft² or less (if otherwise required by §150.1(c)12).
3. **Existing space conditioning systems** that are extended to provide conditioning to an addition are not required to meet the Energy Standards (§150.2(a) Exception 4).
4. **Indoor air quality (IAQ)** requirements (§150.0(o)1C, D, or F) do not apply to additions of 1,000 ft² or less that are not a new dwelling unit.
5. **Photovoltaic (PV)** requirements do not apply to additions/alterations.

A. Addition Alone

In this compliance scenario, the addition alone is modeled using the compliance software, and the existing building is not modeled. This approach may work well when the existing building is not undergoing alterations, and the permitted work scope covers only the addition.

1. **Advantages:** Very little information about the existing building is needed (existing conditioned floor area and number of bedrooms). The existing building is not modeled.
2. **Disadvantages:** Many prescriptive allowances for additions do not apply to the addition alone performance approach. For example, a 400 ft² addition is allowed a 30 percent fenestration area limit if complying using existing + addition, while only 20 percent is allowed when complying as an addition alone. Alterations to the existing conditions that improve the energy performance of the existing building cannot be used in this approach as “trade-offs” with the addition.

B. Existing + Addition + Alteration

In this compliance scenario, the entire building is included in the analysis. This approach does not require unaltered components to be brought into compliance.

1. **Advantages:** This approach offers the most flexibility by modeling improvements to the existing building. The energy budgets include the more generous glazing allowances given to prescriptive compliance. Note: There is no requirement to make alterations to the existing building using this approach.
2. **Disadvantages:** Plans and data for the existing building are needed, increasing the time and complexity of the calculations.

C. Existing + Addition as New Construction

Demonstrating compliance as a whole new building, which entails combining existing plus the addition as all new construction, is another approach. This approach is used when the changes are extensive. Compliance can be difficult because all existing features must be brought up to the current code.

9.3.2 Additions and Alterations Combined

9.3.2.1 Prescriptive

When a low-rise residential project includes an addition and alterations, the prescriptive requirements for each condition must be met. The addition may comply with the appropriate prescriptive addition approach and documented with the applicable form (for example, CF1R-ADD-01).

The alterations must also meet all prescriptive requirements and be documented with the specific compliance documentation for alterations (for example, CF1R-ALT-02).

9.3.2.2 Performance

The performance approach that includes both additions and may include alterations is called “**Existing + Addition + Alterations.**” (See Section 9.5.2.) There are two ways to analyze the building using this method: compliance with third-party

verification of all existing conditions altered or compliance without third-party verification.

9.3.3 Alterations Only

9.3.3.1 Prescriptive

Alterations may comply prescriptively by meeting all applicable requirements in §150.2(b), which are explained further in Section 9.4. Several prescriptive alteration requirements are specific to the building site climate zone. There are also several exceptions based on either climate zone or other conditions.

It is important to note that every applicable prescriptive requirement must be met; otherwise, the building must comply using a performance approach. However, the energy budget is based on prescriptive requirements. So if one or more proposed alterations do not comply, the other alterations must exceed prescriptive requirements, or the project may not comply with the performance approach.

Under the prescriptive alteration approach, the appropriate certificate of compliance (for example, CF1R-ALT-02) form is completed and submitted for a permit. If any mandatory or prescriptive measures require HERS verification or testing (see Section 2.5, HERS Field Verification and Diagnostic Testing of this manual), the certificate of compliance must be completed and registered online with a HERS provider (see Section 2.3 of this manual) before submittal to the enforcement agency.

9.3.3.2 Performance

Alterations may comply using the performance approach by meeting the requirements in §150.2(b)2. This is explained in Section 9.5. The main options are:

1. **Existing + Alterations:** If multiple components or systems are being altered or if the proposed modification(s) exceed the prescriptive requirements, then the existing + alterations performance approach may be used to make trade-offs.
2. **Compliance Without Third-Party Verification:** This option allows for compliance of the alterations without the need for third-party inspection to verify existing conditions being altered.
3. **Compliance With Third-Party Verification:** This option allows for compliance of the alterations only with third-party inspection to verify existing conditions being altered.
4. **Existing + Alterations as new construction:** This option is the most difficult.

9.3.4 Wall Exceptions to Continuous Insulation

9.3.4.1 Wall Extension

When an addition is built with a connection to an existing wood-framed wall, an extension to an existing wood-framed wall (Figure 9-1) is allowed to retain the existing dimensions (§150.2(a)1Ai or 150.2(a)1Biii). Retain the dimensions means two things: (1) if the existing wood-framed wall has no continuous insulation, the

extended wall also does not require continuous insulation; and (2) the existing framing size may be kept.

This exception will typically apply to only one or two walls of an addition. Prescriptive compliance for the walls that meet the criteria will require R-15 cavity insulation if the existing framing is 2x4 or R-21 cavity insulation if the existing framing is 2x6 for the extended wall(s). The energy budget for performance compliance will match the prescriptive requirements.

9.3.4.2 Existing Wall With Siding

Similar to a wall extension is a provision that applies to existing wood-framed walls of a previously unconditioned space. If the existing exterior siding (or cladding) of the structure is not being removed, and the space is converted to conditioned space, §150.2(a)1Aiii or 150.2(a)1Bvi requires only cavity insulation of R-15 in a 2x4 wall or R-21 in a 2x6 wall.

Figure 9-1: Wall Extension

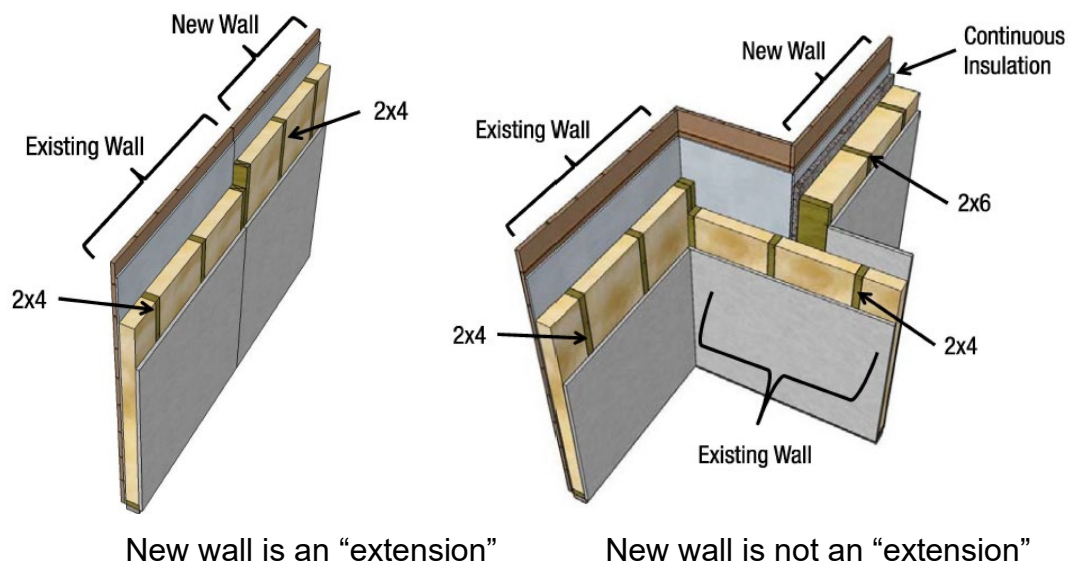

9.3.5 Accessory Dwelling Units (ADUs)

The California Department of Housing and Community Development defines accessory dwelling units as:

“ . . . an attached or detached residential dwelling unit which provides complete independent living facilities for one or more persons. An ADU shall include permanent provisions for living, sleeping, eating, cooking, and sanitation on the same parcel as the single-family dwelling is situated.





State legislation that took effect on January 1, 2017, gave more flexibility to build ADUs, sometimes called “granny” or “in-law” units. For compliance, an ADU may be treated as an addition or may be a new dwelling unit. See Figure 9-2 to determine the compliance requirements. Although the Energy Standards that apply to the ADU may

be the same as an addition, this may not be the same for other parts of Title 24. Check with your local building department to confirm applicable requirements.

ADU compliance requirements are based on the associated Energy Code classification as either an addition to an existing residence or as a new building, as shown in Figure 9-2. An ADU may comply using any of the prescriptive or performance method options available for other residential additions or new buildings plus meeting applicable mandatory measures.

- A. If the ADU shares common walls with the existing dwelling unit and is newly constructed, some of the walls may be wall extensions (Section 9.3.4).
- B. If the ADU shares no common walls with the existing dwelling unit (detached) and is converting an existing unconditioned structured into conditioned space, an exception to the requirement for continuous insulation is available for walls where existing exterior siding (or cladding) is not removed.
- C. If the ADU shares common walls with the existing dwelling unit and is converting an attached unconditioned space into conditioned space, the existing walls of the new ADU may meet an exception to the requirement for continuous insulation if exterior siding is not removed.
- D. If the ADU shares no common walls with the existing dwelling unit (detached) and is a new structure, this is a newly constructed residential building.

Figure 9-2: ADU Types

 <p>Addition: Converting existing unconditioned space, attached to existing home. Walls may qualify as “existing wall with siding.” (See Section 9.3.4 for wall exceptions.)</p>	 <p>Addition: Converting existing unconditioned space, detached from existing home. Walls may qualify as “existing wall with siding.” (See Section 9.3.4 for wall exceptions.)</p>
 <p>Addition: Newly constructed, attached to existing home. One or more walls may qualify as wall extensions. (See Section 9.3.4 for wall exceptions.)</p>	 <p>New Construction: Newly constructed and detached from existing home.</p>

1. HVAC

When adding an attached ADU to an existing home, the Mechanical Code does not allow return air from one dwelling unit to be discharged into another dwelling unit through a shared heating or cooling system. Systems without ducts are an option.

A system serving an ADU must have its own thermostat. Heating systems must be capable of maintaining 68 °F at a point three feet above the floor and two feet from the exterior walls in habitable rooms. Heating and cooling load calculations will need to be provided per Title 24, Part 6, Section 150.0(h) to verify that any existing and/or new system is properly sized,

Any addition that adds a new dwelling unit must meet all applicable IAQ ventilation requirements of Sections 150.0(o)1C. A detached ADU must meet all applicable IAQ ventilation requirements of Sections 150.0(o)1C. An attached ADU must also meet all requirements if the dwelling units do not share a floor or ceiling. The whole house ventilation airflow is to be based on the square footage of the new dwelling unit.

Local exhaust for bathrooms and kitchens is required for any addition. See Table 9-7 in Section 9.4.2 for a more detailed summary of prescriptive HVAC system requirements for additions.

2. Photovoltaics (PV)

Solar electricity generated by photovoltaics (PV) is not required if the ADU is an addition. PV is required for detached, newly constructed ADUs.

Example 9-4:

Question:

An existing single-story residence has a 600 ft² attached unconditioned storage room that the owner plans to turn into an accessory dwelling unit. The existing uninsulated walls have 2x6 wood framing, and the owner plans to keep the existing exterior siding. For prescriptive compliance, what wall insulation is required in the proposed ADU?

Answer:

The proposed ADU is considered an addition for Title 24, Part 6. The existing 2x6 walls can be insulated with R-21 cavity insulation (§150.2(a)1Bvi) for prescriptive compliance. Continuous insulation is not required for these walls.

Example 9-5:

Question:

Can the ADU in the previous example get energy compliance credit using HERS verification of existing conditions for performance method compliance?

Answer:

No. Existing walls in newly conditioned spaces are not eligible for the HERS verification of existing conditions.

Example 9-6:

Question:

In the ADU in the previous example, is solar electricity generated by PV required for prescriptive or performance method compliance?

Answer:

No, PV is not required for Title 24 energy compliance for additions using any compliance approach.

Example 9-7:

Question:

The existing residence in the previous example has a ducted forced-air furnace enough heating capacity to heat the existing residence and the new ADU. Is this allowed for code compliance?

Answer:

No. The California Mechanical Code does not allow return air from an existing forced-air system to be discharged into another dwelling unit through the heating or cooling system. Therefore, the existing ducted furnace may not serve the existing home and the proposed ADU.

9.4 Prescriptive and Mandatory Measures

The prescriptive requirements apply to additions in the same way they apply to new buildings and must be documented on the CF1R-ADD-01 or CF1R-NCB-01 Form.

Except as noted, all applicable prescriptive requirements for additions must be met when using the prescriptive approach. Otherwise, the building must comply using the performance approach.

For prescriptive additions, a certificate of compliance (CF1R-ADD-01 or CF1R-NCB-01) form must be completed and submitted for permit. If any mandatory or prescriptive measures require HERS verification and/or testing, the certificate of compliance for the project must be completed and registered online with a HERS Provider before submittal to the enforcement agency. Refer to Section 2.2.2 and Section 2.5.

There are three prescriptive paths available for additions based on the total conditioned floor area (CFA) of the addition. The total CFA of the addition may include floor areas representing several physically separate additions to the building under the same permit.

Table 9-2 summarizes the key features of the prescriptive envelope requirements for the three prescriptive addition options in §150.2(a)1. Envelope requirements unique to that type of prescriptive addition are shown in bold.

The prescriptive requirements for additions are listed in §150.2(a)1. Unless otherwise noted, the prescriptive requirements contained in §150.1(c) also apply.

- A. Additions ≤ 400 ft²:** All prescriptive requirements must be met **except**:
1. Total glazing area up to 75 ft² or 30 percent of the conditioned floor area, whichever is greater.
 2. Total glazing area maximum for west-facing glazing is 60 ft² or 5 percent in Climate Zones 2, 4, and 6-15.
 3. QII does not apply.
 4. Rafter roof insulation of R-22.
 5. Ceiling insulation of R-38 in Climate Zones 1 and 11-16, or R-30 in Climate Zones 2-10.
 6. Radiant barrier in Climate Zones 2-15.
 7. Extensions of existing wood-framed walls (Figure 9-1) may retain the dimensions of the existing walls and require the following cavity insulation:
 - a. In 2x4 wood-frame walls, insulation shall be R-15.
 - b. In 2x6 or greater wood-frame walls, insulation shall be R-21.
 8. Existing wood-framed walls where existing exterior siding (or cladding) will not be removed, do not need continuous insulation and require only cavity insulation:
 - c. In 2x4 wood-framed walls, insulation shall be R-15.
 - d. In 2x6 or greater wood-framed walls, insulation shall be R-21.
- B. Additions > 400 ft² and ≤ 700 ft²:** All prescriptive requirements must be met **except**:
1. Total glazing area up to 120 ft² or 25 percent of the conditioned floor area.
 2. Total glazing area maximum for west-facing glazing is 60 ft² or 5 percent in Climate Zones 2, 4, and 6-15.
 3. QII does not apply.
 4. Rafter roof insulation of R-22.
 5. Ceiling insulation of R-38 in Climate Zones 1 and 11-16 or R-30 in Climate Zones 2-10.
 6. Radiant barrier in Climate Zones 2-15.
 7. Extensions of existing wood-framed walls may retain the dimensions of the existing walls and require the following cavity insulation:

- a. In 2x4 wood-framed walls, insulation shall be R-15.
 - b. In 2x6 or greater wood-framed walls, insulation shall be R-21.
8. Existing wood-framed walls, where existing exterior siding (or cladding) will not be removed, do not need continuous insulation and require only cavity insulation:
- a. In 2x4 wood-framed walls, insulation shall be R-15.
 - b. In 2x6 or greater wood-framed walls, insulation shall be R-21.

C. Additions > 700 ft²:

1. Total glazing area up to 175 ft² or 20 percent of the conditioned floor area, whichever is greater.
2. Total glazing area maximum for west-facing glazing is 70 ft² or 5 percent in Climate Zones 2, 4, and 6-15.
3. Extensions of existing wood-framed walls may retain the dimensions of the existing walls and require the following cavity insulation:
 - a. In 2x4 wood-framed walls, insulation shall be R-15.
 - b. In 2x6 or greater wood-framed walls, insulation shall be R-21.
4. Existing wood-framed walls, where existing exterior siding (or cladding) will not be removed, do not need continuous insulation and require only cavity insulation:
 - a. In 2x4 wood-framed walls, insulation shall be R-15.
 - b. In 2x6 or greater wood-framed walls, insulation shall be R-21.
5. QII applies to the addition.
6. When an addition greater than 700 ft² is an existing unconditioned space converted to conditioned space, the QII requirements do not include:
 - a. Window and door header insulation.
 - b. Air sealing if the existing air barrier is not removed or replaced.

9.4.1 Prescriptive Additions

Figure 9-3: Prescriptive Addition Envelope Requirements

To provide consistency with existing wall alignment, extensions of the existing wall into the addition shall have R-15 for 2x4 walls and R-21 for 2x6 or greater walls.

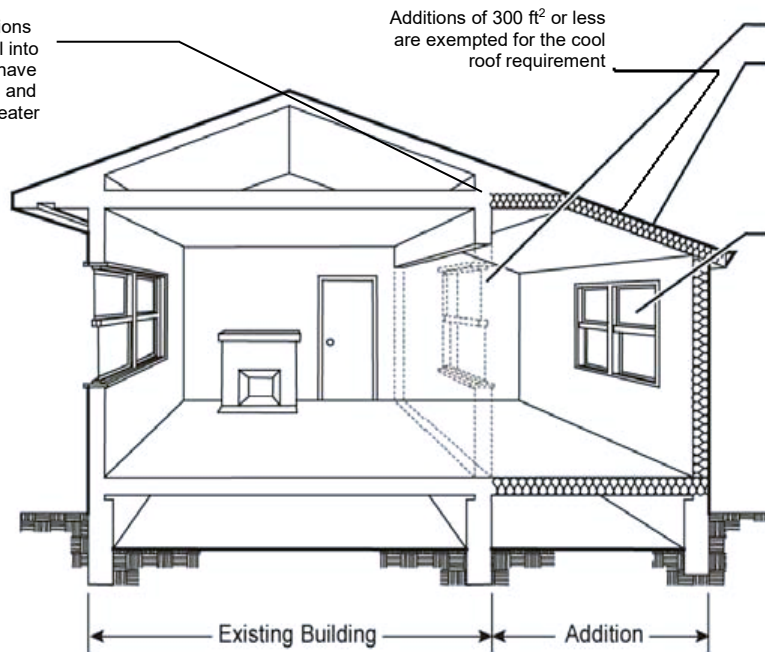

Removed wall and window not included in the calculation.

Insulation requirements from Prescriptive table; unless addition is 700 ft² or less, then meet mandatory minimum roof/ceiling insulation

Fenestration area is limited based on the size of the addition:

- For additions ≤ 400 ft²: 75 ft² or 30% of CFA – whichever is greater -- for total glazing area; and 60 ft² for west-facing glazing.
- For additions > 400 ft² and ≤ 700 ft²: 120 ft² or 25% of CFA – whichever is greater -- for total glazing area; and 60 ft² for west-facing glazing.
- For additions > 700 ft²: 175 ft² or 20% of CFA – whichever is greater -- for total glazing area; and 70 ft² or 5% of CFA – whichever is greater - for west-facing glazing.

Example 9-8

Question:

I am retrofitting an existing home that includes an 800 ft² addition. Part of this addition includes converting a 400 ft² unconditioned garage to conditioned space and adding a 400 ft² bedroom above the garage. If complying prescriptively, is QII required for this addition?

Answer:

Yes. Because this addition, including the conversion of the garage, is greater than 700 ft², QII is prescriptively required. If the existing walls of the garage are remaining and the exterior cladding is not being removed, the QII insulation requirements for window and door headers in the garage walls and QII air-sealing requirements are not required. For all new walls and walls that are being replaced, all aspects of QII must be met. If the performance method is used for compliance, the QII requirements can be traded off with other efficiency measures to meet compliance. The prescriptive wall insulation requirements for existing wood framed walls in the garage are R-15 in 2x4 framing and R-21 in 2x6 framing.

Example 9-9

Question:

A small addition of 75 ft² is planned for a house in Climate Zone 7. An existing porch is being enclosed by extending the existing 2x4 wood-framed walls. The existing heating and air-conditioning system will serve the new conditioned space, including an extension of less than 40 linear feet of new ducts. The contractor wants to follow the prescriptive requirements. What requirements apply?

Answer:

Because the addition is smaller than 400 ft², the total fenestration area is limited to a maximum of 75 ft², and west-facing fenestration area is limited to 60 ft². The fenestration must meet the prescriptive U-factor and SHGC requirements, which are a maximum U-factor of 0.30 and a maximum SHGC of 0.23 in Climate Zone 7.

In Climate Zone 7, for an addition of this size, insulation requirements are R-30 ceiling insulation with radiant barrier, and R-19 floor insulation. The new 2x4 walls that are extensions of existing walls (Figure 9-1), require only R-15 cavity insulation. Any walls that are not extensions must have a maximum 0.065 U-factor. This can be achieved with a 2x4 wood-framed wall with R-15 cavity and R-4 continuous insulation. Since the addition is less than 300 ft² there is no cool roof requirement.

Since existing heating and cooling equipment is used, that equipment does not have to meet the mandatory equipment efficiency requirements. Mandatory duct insulation requirements of §150.0(m) apply to any new ducts, including R-6.0 minimum in unconditioned space. All other mandatory requirements in §150.0 must be met.

Example 9-10

Question:

If I remove a window from the existing house and reuse this window in an addition to that house, does the relocated window have to meet the prescriptive requirements?

Answer:

Yes, if using prescriptive compliance, in which case the relocated window must be treated as a new window and must meet the U-factor and SHGC requirements of §150.1(c)3. If you use this existing window in the addition, you must use the actual or default U-factor and SHGC of the window in showing compliance. Therefore, meeting the prescriptive requirements may not be possible, and performance compliance may be the only option. Window certification and labeling requirements of §110.6(a) do not apply to existing used windows.

Relocated windows must also meet the maximum area-weighted average U-factor in §150.0(q) with the EXCEPTION of up to 10 ft² or 0.5 percent of conditioned floor area, whichever is greater.

Prescriptive Mechanical Measures

For a summary and discussion of prescriptive mechanical requirements when installing new or replacement space-conditioning equipment and/or ducts, see Section 9.6.2.

Example 9-11**Question:**

When using the performance approach for the addition alone, do the refrigerant charge requirements in §150.1(c)7A and fan airflow and watt draw measurements in §150.0(m)13 need to be met for existing air conditioners serving an addition?

Answer:

If existing equipment is used to serve the addition, the refrigerant charge, airflow, and watt draw requirements do not need to be met as specified by Exception 5 to §150.2(a). However, if added ducts to serve the addition are more than 40 linear feet and they are in unconditioned space, then the ducts must be tested and verified by a HERS Rater as described in §150.2(b)1D. All installed ducts regardless of length and location shall be sealed and meet insulation levels as described in §150.0(m) Items 1 through 6.

If a new system is installed to serve the addition, it must meet all of the requirements for space conditioning in a new home.

Table 9-2: Envelope Roof/Ceiling Requirements for Prescriptive Additions

Component	Additions ≤ 400 ft ²	Additions > 400 and ≤700 ft ²	Additions > 700 ft ²
Roof/Ceiling Insulation	CZ 1, 11-16: R-38 CZ 2-10: R-30	Same as ≤ 400 ft ²	Option B or C [C = require ducts and air handler to be in conditioned space] (see Table 9-3 below).
Roof Products (Cool Roof)	Steep Slope (≥2:12): CZ10-15: Reflectance = 0.20 and Emittance = 0.75; or SRI = 16 Low-Sloped (<2:12): CZ 13&15: Reflectance = 0.63 and Emittance = 0.75; or SRI = 75 Exception: Additions ≤ 300 ft ² exempt from cool roof requirements		Steep-Sloped (≥2:12): CZ10-15: Reflectance = 0.20 and Emittance = 0.75; or SRI = 16 Low-Sloped (<2:12) CZ 13&15: Reflectance = 0.63 and Emittance = 0.75; or SRI = 75
Radiant barrier above attic	CZ 2-15: Radiant barrier above attic spaces		CZ 2-15: Radiant barrier above attic spaces except when complying with Option B (see §150.1(c)2)

Figure 9-4: Ventilated Attic Prescriptive Compliance Choices for Additions >700 ft²

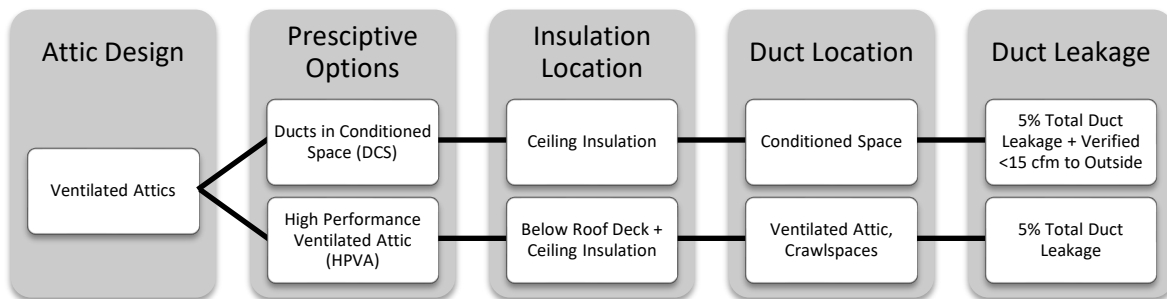

Table 9-3: Roof and Ceiling Requirements for Prescriptive Additions

Component	Option B – Single Family	Option B - Multifamily	Option C (CZ 4, 8-16)
Roof Deck Insulation	Below-deck insulation CZ 4, 8-16: R-19	Below-deck insulation CZ 4, 8, 9, 11-15: R-19 CZ 10, 16: R-13	No roof deck insulation required
Radiant Barrier	CZ 2-3, 5-7	CZ 2-3, 5-7	CZ 2-15
Roofing	Tile roof or other product with an air space	Tile roof or other product with an air space	Tile roof or other product with an air space
Ceiling Insulation	CZ 1, 2, 4, 8-16: R-38 CZ 3, 5-7: R-30	CZ 1, 2, 4, 8-16: R-38 CZ 3, 5-7: R-30	CZ 2-10: R-30 CZ 1, 11-16: R-38
Duct and Air Handler Location	Attic	Attic	Conditioned space

Table 9-4: Envelope Door and Glazing Requirements for Prescriptive Additions

Component	Additions ≤ 400 ft ²	Additions > 400 and ≤ 700 ft ²	Additions > 700 ft ²
Allowable total glazing area	Up to 75 ft ² or 30% of conditioned floor area, whichever is greater	Up to 120 ft ² or 25% of conditioned floor area, whichever is greater	Up to 175 ft ² or 20% of conditioned floor area, whichever is greater
Allowable west-facing glazing area: CZ 2, 4, 6-15	Up to 60 ft ²	Up to 60 ft ²	The greater of 70 ft ² or 5% of conditioned floor area in CZ 2, 4, 6-15
Glazing U-factor & SHGC ¹	All CZs: U = 0.30 CZ 2, 4 & 6-15: SHGC = 0.23	All CZs: U = 0.30 CZ 2, 4 & 6-15: SHGC = 0.23	All CZs: U = 0.30 CZ 2, 4 & 6-15: SHGC = 0.23
Opaque door U-factor	U = 0.20	U = 0.20	U = 0.20
1. See §150.0(q) and §150.1(c)3 for new and replaced window and skylight exceptions.			

Table 9-5: Envelope Wall/Floor Insulation Requirements for Prescriptive Additions

Component	Additions ≤ 400 ft ²	Additions > 400 and ≤700 ft ²	Additions > 700 ft ²
Exterior framed wall ¹ insulation – single-family	CZ 1-5, 8-16: U = 0.048 CZ 6-7: U = 0.065	Same as ≤ 400 ft ²	Same as ≤ 400 ft ²
Exterior framed wall ^{1,2} insulation - multifamily	CZ 1-5, 8-16: U = 0.051 CZ 6-7: U = 0.065		
Extension of existing wood-framed wall Or Existing wood-framed wall with exterior siding (or cladding) to remain	R-15 in 2x4 wood framing R-21 in 2x6 wood framing		
Raised floor ¹ insulation	All CZs: R-19 or U = 0.037		
Slab floor ¹ perimeter insulation	CZ 1-15: No requirement CZ1: R-7 or U = 0.58		
<p>1. See Table 150.1-A and 150.1-B for requirements for non-framed walls including mass walls 2. R-values refer to wood framing, and U-factors refer to metal framing.</p>			

Table 9-6: QII Requirements for Prescriptive Additions

Component	Additions \leq 400 ft²	Additions > 400 and \leq 700 ft²	Additions > 700 ft²
Single-family additions – new structure	No requirement	No requirement	All CZs: Required (Does not apply to any altered spaces)
Multifamily additions – new structure	No requirement	No requirement	CZ 1-6, 8-16: Required CZ 7: No requirement (Does not apply to any altered spaces)
Converting unconditioned to conditioned space	No requirement	No requirement	Same as above except: <ul style="list-style-type: none"> • Window and door header insulation • Air sealing if the existing air barrier is not removed or replaced

Table 9-7: HVAC and Water Heating Requirements for Prescriptive Additions

Component	Additions ≤ 400 ft ²	Additions > 400 and ≤700 ft ²	Additions > 700 ft ²
Ventilation cooling ¹ (whole-house fan)	No Requirement	Same requirements as ≤400 ft ²	Additions ≤ 1000 ft ² – no requirement Additions > 1,000 ft ² : CZ 8-14 - required
Adding new space conditioning system(s)	All prescriptive requirements		All except requirement for ducts in conditioned space ²
Replacing existing space conditioning system(s)	All prescriptive requirements		All except requirement for ducts in conditioned space ²
Adding all new complete duct system(s)	All prescriptive requirements		All except requirement for ducts in conditioned space ²
Extending existing duct system(s) by > 40 feet	All duct insulation, duct system sealing, and HERS verification		All duct insulation, duct system sealing, and HERS verification, Except requirements for ducts in conditioned space ²
1. (Note: also mandatory mechanical ventilation per ASHRAE 62.2 with HERS verification for additions > 1,000 ft ²) 2. For more information about ducts in conditioned space, see Section 3.5.3.5.			

9.4.2 Water Heating System

If an addition increases the number of water heaters serving a dwelling unit, the addition can comply prescriptively if one of the conditions contained in §150.2(a)1D.i or ii are met. The most common option is a natural gas or propane tankless water heater.

For a complete list of options, see Chapter 5.

9.4.3 Alterations – Prescriptive/Mandatory Requirements

This section provides a road map and a few relevant summaries that identify the requirements unique to alterations. Envelope, mechanical, and water-heating system alterations must meet all applicable mandatory requirements and comply with either the prescriptive or performance approach. If a building does not meet all applicable prescriptive measures, then the performance method using of approved compliance software is the alternative. This section describes the mandatory requirements for low-rise residential buildings as they apply to additions and alterations. More information on the mandatory measures can be found in Chapters 3, 4, 5, and 6.

Residential lighting alterations need to meet applicable mandatory measures. There are no prescriptive lighting requirements in residential buildings.

Although alterations must meet many of the same prescriptive requirements for new construction and additions, there are several exceptions or special allowances for certain types of alterations.

9.4.4 Envelope Alterations

This section summarizes requirements for many typical residential envelope alterations.

Table 9-8: For Residential Alterations, Summary of Mandatory and Prescriptive Measures

Envelope Alteration Type	Applicable Mandatory Measures ¹	Summary of Relevant Prescriptive Measure(s) ²	Exception(s) to the Prescriptive Measures
Adding ceiling insulation to an existing roof; or a new roof on an existing building	Ceiling w/ attic and roof rafters: R-19, U=0.054 §150.0(a)	N/A	N/A
Adding exterior framed wall insulation	In 2x4 framing: R-13, U=0.102 In 2x6 framing: R-20, U=0.071 Exception: Walls already insulated to R-11 §150.1(c)	Same as mandatory	N.A
Mass/concrete walls	See §150.1(c) for applicable climate zone	Same as mandatory	N/A
Replacing > 50% of existing roof surface, including adding a new surface layer on top of existing exterior surface	§110.8(i)	<p><u>Steep-Sloped</u> (≥ 2:12): CZ 10 - 15: Reflect.≥0.20 and Emittance≥0.75; or SRI≥16</p>	<p>(a) Air space 1.0" between roof deck and bottom of roofing product</p> <p>(b) Profile ratio of rise to width of 1:5 for >50% width of roofing product.</p> <p>(c) Existing ducts in attic insulated and sealed per §150.1(c)9.</p> <p>(d) Roof has ≥ R-38 ceiling insulation.</p> <p>(e) Roof has a radiant barrier per §150.1(c)2.</p> <p>(f) No ducts in attic.</p> <p>(g) In CZ10-15, >R-2.0 insulation above roof deck</p>
		<p><u>Low-Sloped</u> (< 2:12): CZ13 & 15: Reflectance ≥ 0.63; Emittance ≥ 0.75</p>	<p>(a) There are no ducts in the attic.</p> <p>(b) Reflectance and Roof Deck Insulation R-value in Table 150.2-A are met</p>

Table 9-8: For Residential Alterations, Summary of Mandatory and Prescriptive Measures (continued)

Envelope Alteration Type	Applicable Mandatory Measures ¹	Summary of Relevant Prescriptive Measure(s) ²	Exception(s) to the Prescriptive Measures
Adding or replacing skylight ³	Weighted average U-factor ≤ 0.58 Exemption: Up to 20 ft ² or 0.5% of conditioned floor area, whichever is greater, is exempt from the U-factor requirement of §150.0(q)	Must not exceed 20% total (all CZs) and 5% west fenestration area (CZ 2, 4, 6-15) with a U-factor ≤ 0.30 (all CZs); in CZ2, 4 & 6-15: SHGC ≤ 0.23 §150.2(b)1A	Up to 75 ft ² need not meet total or west-facing fenestration area per §150.2(b)1A Exception 1 Replacement skylights up to 16 ft ² with a $U \leq 0.55$ and SHGC ≤ 0.30 and not meet total fenestration and west-facing area requirements per §150.2(b)1A Exception 2
Adding raised floor insulation	R-19 or equivalent U-factor Exception: Floors over controlled ventilation or unvented crawlspaces per §150.0(d)	Same as mandatory	N/A
Replacing vertical fenestration ³ (altered glazing)	Weighted average U-factor ≤ 0.58 Exemption: Up to 10 ft ² or 0.5% of conditioned floor area, whichever is greater, is exempt from the U-factor requirement of §150.0(q)	Must not exceed 20% total (all CZs) and 5% west fenestration area (CZ 2, 4, 6-15) with a U-factor ≤ 0.30 (all CZs); in CZ2, 4 & 6-15: SHGC ≤ 0.23 §150.2(b)1A	Up to 75 ft ² need not meet total or west-facing fenestration area per §150.2(b)1A Exception 1 Replacement skylights up to 16 ft ² with a $U \leq 0.55$ and SHGC ≤ 0.30 and not meet total fenestration and west-facing area requirements per §150.2(b)1A Exception 2
Adding vertical fenestration ³ (new glazing) and greenhouse	Weighted average U-factor ≤ 0.58 Exemption: Up to 10 ft ² or 0.5% of conditioned floor area, whichever is greater, is exempt from the U-factor requirement of §150.0(q)	Must not exceed 20% total (all CZs) and 5% west fenestration area (CZ 2, 4, 6-15) with a U-factor ≤ 0.30 (all CZs); in CZ2, 4 & 6-15: SHGC ≤ 0.23 §150.2(b)1A	Up to 75 ft ² need not meet total or west-facing fenestration area per §150.2(b)1A Exception 1 Added greenhouse must either meet the maximum or weighted average U-factor of 0.58 or up to 10ft ² or 0.5% of CFA whichever is greater as per Exception 1 to §150.0(q)1

1. Alterations must comply with all applicable mandatory measures in §110.0 and §150.0 of the Energy Standards as explained in Chapters 3, 4, 5 and 6 of this manual, except as noted in §150.2(b).

2. Several prescriptive measures are climate zone (CZ) specific.

3. Replacement fenestration may include fenestration that is located in the same existing wall or roof in which the same or larger area of existing fenestration is being removed. This is labeled as "altered." Any new fenestration area that increases the total net area of fenestration in any existing wall or roof is labeled as "new."

9.4.4.1 Replacing the Roof Surface or Roof Sheathing (Partial or Entire Replacement)

A. Steep-Sloped Roofs ($\geq 2:12$)

In Climate Zones 10 through 15, if 50 percent or more of the roof surface of an existing building is being replaced, the minimum cool roof requirement for the replaced steep-sloped roofing area shall have an aged solar reflectance of 0.20, thermal emittance equal to 0.75, or a minimum SRI of 16. The requirements above apply unless one of the following is present (considered equivalent to the cool roof requirements in §150.2(b)1Hi):

1. Air space of 1.0" (25mm) between the roof deck and the bottom of the roofing product.
2. Roofing product profile ratio of rise to width is at least 1:5 for >50 percent width of roofing product.

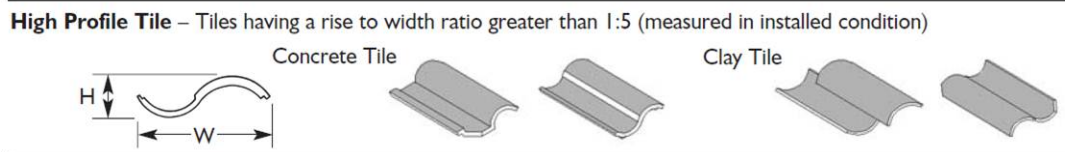

3. Existing ducts in attic are insulated and sealed according to §150.1(c)9.
4. Building has at least R-38 roof/ceiling insulation.
5. Roof of attic spaces has a radiant barrier according to §150.1(c)2.
6. There are no ducts in the attic space.
7. In Climate Zones 10 through 15, there is greater than R-2.0 insulation above the roof deck.

B. Low-Sloped Roofs ($< 2:12$)

In Climate Zones 13 and 15, if 50 percent or more of the roof surface of an existing building is being replaced, the minimum cool roof requirements for low-sloped roofs shall have an aged solar reflectance of 0.63, thermal emittance of 0.75, or a minimum SRI of 75 per §150.2(b)1Hii. These apply unless one of the following is present, which is considered equivalent to the cool roof requirements in §150.2(b)1Hii:

1. There are no ducts in any attic space.
2. The aged solar reflectance can be traded off with additional insulation added at the roof deck as specified in Table 150.2-B of the Energy Standards.

Table 9-9: Aged Solar Reflectance Insulation Trade Off

Aged Solar Reflectance	Roof Deck Insulation R-value	Aged Solar Reflectance	Roof Deck Insulation R-value
0.62 – 0.60	2	0.44 – 0.40	12
0.59 -0.55	4	0.39 – 0.35	16
0.54 - 0.50	6	0.34 – 0.30	20

0.49 – 0.45	8	0.29 – 0.25	24
-------------	---	-------------	----

C. Roofing Products: Cool Roof

Cool roofs are not just white roofs but are products (tile, asphalt shingles, etc.) designed to reflect much of the sun's radiant energy back into space instead of transferring it as heat into the building below. The two basic characteristics that determine the performance of a cool roof are solar reflectance and thermal emittance. These roofing products must be certified by the Cool Roof Rating Council (www.coolroofs.org) per §10-113 and §110.8(i).

A cool roof requires the roofing product manufacturer to test for solar reflectance and thermal emittance and be listed in the Cool Roof Rating Councils (CRRC) Rated Product Directory. Figure 9-5 provides an example of an approved CRRC product label.

Figure 9-5: CRRC Product Label and Information

	Solar Reflectance	<u>Initial</u> 0.00	<u>Weathered</u> Pending
	Thermal Emittance	0.00	Pending
	Rated Product ID Number	----	
	Licensed Seller ID Number	----	
Classification		Production Line	
<small>Cool Roof Rating Council ratings are determined for a fixed set of conditions, and may not be appropriate for determining seasonal energy performance. The actual effect of solar reflectance and thermal emittance on building performance may vary.</small>			
<small>Manufacturer of product stipulates that these ratings were determined in accordance with the applicable Cool Roof Rating Council procedures.</small>			

If the aged value for the reflectance is not available in the CRRC Rated Product Directory, the equation below is used.

Equation 9-1: Aged Reflectance

$$\text{Aged Reflectance}_{\text{calculated}} = (0.2 + \beta[\rho_{\text{initial}} - 0.2])$$

Where:

ρ_{initial} = Initial Reflectance listed in the CRRC Rated Product Directory

β = soiling resistance value listed in Table 9-10

Table 9-10: Soiling Resistance Value β , by Product Type

PRODUCT TYPE	β
Field-applied coating	0.65
Other	0.70

Since this is not a mandatory requirement, if prescriptive compliance for a given roof slope and climate zone require a minimum reflectance and emittance, you can either meet one of the exceptions above or use the performance compliance approach to use some other building feature to trade off the requirement.

Example 9-12**Question:**

There is a Victorian building that has been converted into an office building and needs to have a shake roof replacement. This building has a vented unconditioned attic with the insulation on the ceiling. Would I need to meet §150.2(b)Hi?

Answer:

No, this section does not apply. The occupancy type has been changed to nonresidential. Since the Victorian building has a shake roof and is considered a steep-sloped roof, §141.0(b)2Bib for nonresidential buildings would apply.

Example 9-13**Question:**

On an existing building, 50 ft² of 85 ft² of vertical glazing is being removed from an existing south-facing wall and new glazing will be replaced as part of the alteration in the same opening. What requirements apply?

Answer:

Since 50 ft² is “replacement” fenestration and 35 ft² is existing, the replaced fenestration must comply with the §150.2(b)1B. For this example, Exception 1 to §150.2(b)1B can be used. This allows vertical fenestration no greater than 75 ft² to meet have a U-factor no greater than 0.40 in Climate Zones 1-16 and an SHGC of 0.35 or less in Climate Zones 2, 4, and 6 through 15.

9.4.4.2 Insulating Existing Roof/Ceilings, Walls, and Raised Floors

When insulation is added to an existing ceiling of an existing conditioned space, at least R-19 (or a maximum U-factor of 0.054) is required in all climate zones. When insulating a rafter roof, at least R-19 (maximum U-factor of 0.054) is required.

When a roof surface is altered, if the space between framing members becomes accessible, the ceiling/roof is considered altered, and insulation is required.

The prescriptive requirement for alterations to walls and floors is to add the equivalent of the specified level of insulation that fits within the cavity of wood-framed assemblies:

1. R-15 in 2x4 exterior walls, and R-21 in 2x6 or greater exterior walls (no exterior continuous insulation is required); or
2. Existing buildings that already have R-11 insulation installed in framed walls are exempt from the mandatory minimum R-13 or R-20 wall insulation required by §150.0(c) if the building can demonstrate performance compliance with the walls modeled as R-11; or
3. R-19 in raised floors over crawl spaces, over open outdoor areas, unheated basements, and garages.

9.4.4.3 Fenestration

A. Replacement Fenestration

Any fenestration (i.e., windows, skylights, clerestories, and glazed doors) that is being removed and replaced in an exterior wall or roof is considered “replacement fenestration.”

Replacement fenestration is an area of new fenestration that replaces an equal or lesser area of glazing removed in the same existing wall or roof area. It is labeled as “altered” fenestration, and it need not occur in the same openings as the glazing being removed as long as it is being installed in the same existing wall or roof surface that remains a part of the existing building. Any added fenestration area that is larger than the total altered glazing area is labeled as “new.”

B. New Fenestration in Alterations

The Energy Standards have relaxed some of the prescriptive restrictions on new vertical fenestration for alterations in existing homes. When new vertical fenestration is added in existing dwellings, up to 75 ft² are not required to meet the overall total fenestrations limit (20 percent of the CFA) and the west facing area limit (5 percent of the CFA). This provides for additional flexibility to meet the Energy Standards requirements using the prescriptive approach, without having to comply using the performance approach. However, this additional fenestration must meet the prescriptive U-factor and SHGC requirements or meet the U-factor and SHGC requirements of Exceptions 1 and 2 to §150.2(b)1B.

C. Greenhouse Windows

Greenhouse or garden windows are special windows that project from the façade of the building and are typically five-sided structures. An NFRC-rated U-factor for greenhouse windows is typically high and may not meet the mandatory requirements for the fenestration U-factor of 0.58.

To meet this mandatory measure, greenhouse windows:

1. Must have a maximum U-factor of 0.58 or better; or
2. Must use the area-weighted average for all new and replacement fenestration with a combined mandatory maximum of 0.58 U-factor as per §150.0(q)2; or
3. Must meet the Exception 1 to §150.0(q)1 for up to 10 ft² or 0.5 percent of CFA, whichever is greater.

D. Labeling, Certification, and Other Mandatory Requirements

See Chapter 3 for a full list of mandatory requirements for certification and labeling for fenestration products and exterior doors (§110.6), and air leakage requirements (§110.7).

Example 9-14

Question:

An alteration in Climate Zone 12 is to move an existing 25 ft² window to another location within the same existing wall. What prescriptive requirements does the relocated window need to meet?

Answer:

Removing glazing from an existing wall and reinserting up to the same area of glazing in a different opening is an alteration, covered by §150.2(b)1B. Exception 1 to §150.2(b)1B states that up to 75 ft² of vertical replacement fenestration is allowed to meet a prescriptive requirement of 0.40 U-factor and 0.35 SHGC.

Example 9-15

Question:

For additions and alterations that include a greenhouse window (also known as garden window), how do I measure the fenestration area? What U-factor and SHGC requirements apply to a greenhouse window?

Answer:

The area of a greenhouse windows is the rough opening in the wall.

The default U-factor for greenhouse windows does not meet the mandatory maximum fenestration U-factor of 0.58 (there is no mandatory SHGC requirement). A metal-framed greenhouse window from Table 110.6-A has a 1.40 U-factor and the default SHGC from Table 110.6-B is 0.73 (for fixed, clear glass). By comparison, fenestration in prescriptive additions has to meet the prescriptive U-factor of 0.30 for all climate zones and an SHGC of 0.23 in all climate zones except 1, 3, 5, and 16, which have no SHGC requirement. There are two options to meet the mandatory U-factor requirement: (1) up to 30 ft² is exempt (§150.0(q), Exception 2), and (2) a weighted-average U-factor with other fenestration products is allowed.

For additions and alterations, Exception 1 to §150.2(b) allows any dual-pane greenhouse window to meet the prescriptive U-factor requirement (separate from the mandatory requirement). This makes it possible for greenhouse windows to comply as part of a prescriptive alteration if there is no SHGC requirement (Climate Zones 1, 3, 5, and 16). For climate zones with an SHGC requirement, if other windows are being altered, a weight-average SHGC may be calculated, or performance compliance is an option for achieving compliance. Compliance will likely depend on higher-than-average energy efficiency for some other components of the project to offset the poor performance of the greenhouse windows.

For other alternatives, see Chapter 3.

Example 9-16

Question:

An existing house in Climate Zone 12 has all single-pane windows. Most of the windows (300 ft² total) will be replaced within existing openings. One existing 30 ft² window is being replaced with a pair of 40 ft² French doors. What requirements apply to this project?

Answer:

For prescriptive compliance, replacement fenestration (equal to or less than the area of existing windows in each wall being altered) and added fenestration area must meet the U-factor (0.30) and SHGC (0.23) in Table 150.1-A or B. There are only 10 ft² of added fenestration, so the project meets Exception 1 to 150.2(b)1A and is not required to meet the prescriptive total glazing area requirement. All installed fenestration also must meet applicable mandatory measures.

For performance compliance:

(a) Using the Existing + Alterations approach *without* third-party verification, replacement fenestration that achieves the fenestration values in Table 150.2-C of the Energy Standards is compared to those same values in the standard design. Replacement fenestration that does not reach these values is penalized.

(b) Using the Existing + Alterations approach *with* third-party verification, replacement fenestration that achieves the fenestration values in Table 150.2-C of the Energy Standards is compared to §Tables 110.6-A and 110.6-B default values for the existing fenestration condition. Replacement fenestration that does not reach these values is penalized.

Example 9-17

Question:

An existing building has all single-pane, metal-frame windows. A proposed remodel will replace all the windows; no other work is being done as part of the remodel. What applies?

Answer:

All replacement windows must meet the prescriptive requirements (§150.2(b)1B), and new fenestration must meet applicable mandatory measures of §110.6, §110.7, and §150.0.

If the prescriptive requirements cannot be met, the Existing + Alteration performance method can be used.

Example 9-18

Question:

An existing building has all single-pane, wood-framed windows. In addition to replacing more than 75 ft² of window area, two double-pane, metal-frame greenhouse windows will be added. How should the greenhouse windows be shown to comply using the prescriptive standards?

Answer:

Greenhouse windows add conditioned volume but do not add conditioned floor area. There are three unique requirements (1) prescriptive SHGC, (2) prescriptive U-factor, and (3) mandatory U-factor. Any dual-glazed greenhouse windows installed as part of an alteration must meet any SHGC requirements (0.23 or lower in Climate Zones 2, 4, 6-15, no requirement in other climate zones). While the prescriptive U-factor requirements do not apply (§150.2(b) Exception 1), all applicable mandatory measures must be met. This includes §150.0(q), which requires a maximum weighted average U-factor of 0.58 or less. Exception 2 exempts up to 30 ft² from this requirement.

Example 9-19

Question:

Why is the low-sloped roofing products requirement listed for only Climate Zones 13 and 15?

Answer:

These two climate zones are the only climate zones that show energy cost-effectiveness for having a low-slope roofing product (cool roof) requirement.

Example 9-20

Question:

Why are there so many exceptions to the addition and alterations section that can be considered equivalents to roofing products?

Answer:

There are several energy features that are equivalent or having a greater impact on energy savings than the roofing products. For example, older homes often have ducts under the house, and newer homes may have materials slightly below current requirements or equal to one of the items considered to be equivalent. If the ducts are insulated and air leakage controlled to meet current requirements, energy savings are expected to be at least equal the benefit of reflective roof coverings.

Example 9-21

Question:

What happens if I have a low-slope roof on most of the house but a steep-sloped roof on another portion? Do I have to meet two criteria for the roofing products?

Answer:

Yes. If your house is in Climate Zone 13 or 15, you will need to meet the low-slope criteria for the areas with low slope. The areas with the steep-slope roof will need to meet the other cool roof criteria.

Example 9-22

Question:

I am replacing my existing wood shake roof with asphalt shingles. Would this be considered a repair?

Answer:

No. A repair is defined as a reconstruction or renewal for maintenance of any component, system, or equipment of an existing building. A replacement of any component (i.e., roof-top), system, or equipment for which there are requirements in the Energy Standards is considered an alteration and not a repair.

Example 9-23**Question:**

If a radiant barrier is required for my addition, where does it need to be installed?

Answer:

The radiant barrier needs to be installed only on the underside of an attic roof assembly and the gable wall ends associated with the addition.

Example 9-24**Question:**

I am considering reroofing my house. Under what conditions will I be required to put on a cool roof?

Answer:

Cool roof requirements are triggered when 50 percent or more of the roof area is being replaced. Prescriptive requirements are waived if one of the exceptions to §150.2(b)1H below applies:

Prescriptive Exceptions for Steep-Sloped Roofs

1. Air-space of 1.0 inch (25 mm) is provided between the top of the roof deck and the bottom of the roofing product.
2. The installed roofing product has a profile ratio of rise to width of 1 to 5 for 50 percent or greater of the width of the roofing product.
3. If existing ducts in the attic are insulated and sealed according to §150.1(c)9.
4. Buildings have at least R-38 ceiling insulation.
5. Buildings have an attic radiant barrier meeting the requirements of §150.1(c)2.
6. Buildings have no ducts in the attic.
7. Buildings are in Climate Zones 10-15, R-2 or greater insulation above the roof deck.

Prescriptive Exceptions for Low-Sloped Roofs

1. Buildings have no ducts in the attic.

2. Aged solar reflectance and roof deck insulation R-value in Table 150.2-A are met. Alternatively, the building may show compliance using the performance approach.

Example 9-25

Question:

I am building a 450 ft² addition on my house. Do I have to meet cool roof requirements in the prescriptive package?

Answer:

Yes. Once the addition exceeds 300 ft², if using prescriptive compliance is in a climate zone with a cool roof requirement, the roof must meet the requirements for the type of roof slope. To avoid the cool roof requirements for this addition, you may use the performance approach and trade-off against other energy efficiency features of the addition alone or the existing building by using the Existing + Addition + Alterations approach.

9.4.5 Water Heating Alterations

For a replacement water heater, there are separate requirements for the distribution system and the water heater. The requirements for pipe insulation are mandatory and cannot be traded off. For the distribution system and the water heater, if the prescriptive requirements cannot be met, then the performance compliance method can be used to comply.

The mandatory pipe insulation requirement includes the following:

1. Any newly installed piping must meet mandatory insulation requirements in §150.0(j)2.
2. Any accessible existing piping must be insulated on (1) the first 5 feet of cold water pipes from the storage tank, and (2) all hot water piping less than ¾-inch that is:
 - (a) Associated hot water recirculation system.
 - (b) Piping from the heating source to the kitchen.
 - (c) Piping from the heating source to a storage tank.
 - (d) Or piping that is buried below grade.

To meet the prescriptive requirements, the replacement water heater must be one of the following:

1. Any natural gas or propane water heater
2. If there is no natural gas connected to the existing water heater location, a consumer electric water heater
3. In Climate Zones 1-15, a single heat pump water heater meeting NEEA Tier 3 or higher specifications with the tank located in an unconditioned space like the garage or in conditioned space

4. In Climate Zones 1-15, a single heat pump water heater, (1) located in an unconditioned space like the garage or in conditioned space, (2) placed on an incompressible (rigid) surface that is insulated to a minimum R-10, and (3) installed with a communication interface (demand control device) meeting §110.12(a).

If a recirculation system is installed, then it must be a demand recirculation system with a manual on/off control to meet the prescriptive requirements.

9.4.5.1 Trouble-shooting Water Heater Problems

If installing a recirculation system to reduce the long wait time for hot water, the only system type allowed in an alteration is a demand recirculation system with manual on/off controls. Any other alteration to the hot water distribution system, such as timer or temperature control recirculation systems, must be analyzed using the performance compliance approach to show that the energy use of the building has not been increased.

Another alternative is to install a natural gas or propane instantaneous (tankless) water heater closer to the fixtures having problems. Any other type of water heater may be installed as long as compliance is demonstrated using the performance compliance approach. (See Section 9.5.)

For more information on any of these requirements, see Chapter 5.

Example 9-26

Question:

I want to install an additional water heater to a single-family home with an existing natural gas water heater. Does this comply?

Answer:

It depends on the type of water heater. An instantaneous gas or propane water heater complies with §150.2(a)1D. For prescriptive compliance, the same options allowed for new construction are allowed for an addition. (See Chapter 5.) Otherwise performance compliance may be used to demonstrate compliance.

Example 9-27

Question:

An existing 1,500 ft² single-family home is getting a 500 ft² addition. A new 50-gallon gas water heater will replace the existing water heating system. How do the water heating requirements apply?

Answer:

Because this is an alteration or replacement (§150.2(b)1H) of an existing water heating system, this proposed replacement meets the requirement of §150.2(b)1Hiii.

Any applicable mandatory measures must also be met. For newly installed piping, all the applicable insulation requirements of §150.0(j)2 shall be met. For existing piping that is accessible, the insulation requirements §150.0(j)2 shall be met, which includes the first five feet of cold water lines from the storage tank and all hot water piping. If building energy compliance is achieved with the existing + addition + alterations calculation, the UEF or EF and other energy features of the altered water heating system are modeled in the performance method.

Example 9-28

Question:

An existing 2,000 ft² single-family house has one 50-gallon gas water heater, and a 600 ft² addition with a new instantaneous gas water heater is proposed. How does this comply?

Answer:

When there is an increase in the number of water heaters with an addition, the Energy Standards allow addition-alone compliance in certain circumstances. An instantaneous gas water heater is one of those circumstances. Compliance with applicable mandatory requirements is also needed.

The alternative to show compliance is by using the existing-plus-addition or whole-building compliance.

Example 9-29

Question:

An existing single-family home with one electric water heater has a 500 ft² addition with a 30-gallon electric water heater proposed. Does this comply with prescriptive addition requirements?

Answer:

No. When there is an increase in the number of water heaters with an addition, the prescriptive compliance option is to meet the same requirements as for new construction. The only electric option is a heat pump water heater. (See §150.1(c)8iv or v for a full list of requirements, or Chapter 5 of this manual.)

Performance compliance may be possible. There is a significant penalty for electric resistance water heating.

9.4.6 HVAC System Alterations

If the heating and cooling system is unchanged as part of an addition or alteration, compliance for the HVAC system is not necessary. Changing, altering, or replacing any component of a system often triggers a requirement to seal the ducts. A HERS Rater verifies the duct leakage is less than 15 percent. However, since the ducts are existing, if 15 percent leakage is not feasible, there are alternatives, including all

accessible leaks being sealed and confirmed by a visual inspection (Section 150.2(b)1E).

Extending ducts to condition an addition is not an alteration, however if more than 40 feet of new ductwork is installed in unconditioned space, Section 150.2(b)1D contains duct leakage requirements.

When the duct system is entirely new or a complete replacement, then mandatory and prescriptive requirements apply. (See below.)

9.4.6.1 HVAC "Changeouts"

The Energy Standards make a distinction between two HVAC "changeout" situations:

1. Entirely new or complete replacement space conditioning systems
2. Altered space conditioning systems

A. Entirely New or Complete Replacement Space Conditioning Systems

An entirely new or complete replacement must meet all applicable mandatory measures. (See Chapter 4.)

Completely new or replacement duct systems in *multifamily* dwelling units must meet the 12 percent (total leakage protocol) or 6 percent (leakage to outside protocol) criteria used for newly constructed systems (may also use the smoke test protocol if the system does not meet these criteria) (§150.2(b)1DiiAll). Otherwise, altered duct systems in multifamily dwelling units shall meet the 15 percent (total leakage protocol), 10 percent (leakage to outside protocol), or smoke test criteria given in §150.2(b)1DiiAllB.

A system installed in an existing dwelling as part of an alteration shall be considered entirely new when:

1. The air handler and all the system heating/cooling equipment (e.g., outdoor condensing unit and indoor cooling or heating coil for split systems; or complete replacement of a package unit), are new.
2. The duct system is entirely new (including systems with less than 40 feet in length).

B. Duct Systems – Altered or New

Whether a duct system is altered or new affects which mandatory requirements apply and duct leakage requirements. An altered duct system installed in an existing home is entirely new when:

1. At least 75 percent of the duct material is new.
2. All remaining components from the previous system are accessible and can be sealed.

Entirely new or complete replacement systems must meet mandatory requirements including:

1. Section 150.0(m)12 – air filtration requirements.
2. Section 150.0(m)13 – HSPF/PSFP, airflow and fan efficacy requirements (or alternative return duct sizing as per Table 150.0-B and C).

These requirements are detailed in Chapter 4.

Altered duct systems that are not entirely new or complete replacements are treated as an extension of an existing system.

C. New and Altered Duct System – Insulation

When any new ducts are installed in an unconditioned space, the duct must be insulated to a minimum R-value as described in Table 9-11.

Table 9-11: Duct Minimum R-Value

Climate Zone	1 -10, 12 & 13	11, 14 -16
Duct R-value	R-6	R-8

When more than 40 linear feet of ducts are installed in conditioned space, the ducts must be insulated to the minimum mandatory insulation level of R-4.2 and be verified to be in conditioned space by both visual verification and diagnostic testing in accordance to RA3.1.4.3.8.

D. Duct Sealing

Duct systems meet duct sealing requirements found in Table RA3.1-2.

A new duct system may include an existing air handler, which leaks substantially more than new equipment. If the 5 percent leakage rate criteria cannot be met, a smoke test should be performed to verify that the excess leakage is non-accessible and not from other *accessible* portions of the duct system. The protocol for the smoke test for accessible-duct sealing is given in RA3.1.4.3.7.

If 40 feet of duct are being added or replaced, this work alone can trigger the requirement for duct sealing and field verification. The system would have to meet one of the leakage criteria for “altered existing systems” cases in Table RA3.1-2.

All climate zones require that existing duct systems must be sealed by the installer and verified by a HERS Rater when portions of the heating and cooling system are altered.

When an air handler is installed or replaced, ducts must be sealed (as described below) under any of the following conditions:

1. An outdoor condensing unit of a split system air conditioner or heat pump is installed or replaced.
2. A packaged system is completely replaced.
3. A cooling or heating coil is installed or replaced.
4. More than 40 feet of new or replacement ducts are installed.

If a residence has more than one duct system, only the ducts connected to the altered equipment need to be sealed and verified.

There are three options for showing compliance for existing duct systems listed below. The HERS Rater or installing contractor must at least attempt compliance with the first option (15 percent leakage); then any of the other options can be used:

1. Total leakage is less than 15 percent of nominal system fan airflow (RA3.1.4.3.1).
 2. Leakage to the outside is less than 10 percent of system fan airflow (RA3.1.4.3.4).
 3. If the first option (15 percent) leakage target cannot be met, then compliance can be achieved by sealing all accessible leaks verified by a HERS Rater inspection. When using this option, sampling is not allowed (RA3.1.4.3.5-7).
- HERS field verification is required for all options listed above. For Options 1, and 2, verification can be accomplished through sampling as described in *Sampling for Additions or Alterations* below. For Option 3, sampling is not allowed; a certified HERS Rater must do the visual inspection and the smoke test on every house.
 - Since test equipment must be set up for Option 1, it may be most efficient to test and record the results and then attempt to meet each option sequentially until compliance is achieved.
 - There are a few cases where duct sealing and duct leakage verification are not required. These exceptions include:
 - Ducts that have already been sealed, tested, and certified by a HERS Rater.
 - Duct systems with less than 40 feet of duct.
 - Duct systems that are insulated or sealed with asbestos.

If altered ducts, heating or cooling equipment, or plenums are in a garage, the duct sealing requirements (not limited to 40 feet of new duct) are one of the following:

1. Leakage is less than or equal to 6 percent of air handler airflow (RA3.1.4.3.1).
2. All accessible leaks in the garage space are sealed, and both a visual verification and smoke test are performed by a HERS Rater using methods from RA3.1.4.3.5.

E. Accessible Ducts

Some judgment is required in determining if ducts are accessible. The local code enforcement agency will have the final say when it is not immediately obvious.

F. Refrigerant Charge Verification

In Climate Zones 2 and 8 through 15, when a refrigerant-containing component of an air conditioner or heat pump is replaced or installed in an existing building,

§150.2(b)1F requires a system that does not have a fault indicator display (FID) installed to have refrigerant charge field verified in accordance with all applicable procedures specified in RA3.2.2, or RA1.

1. **Minimum Airflow.** When RCV is required for compliance, the system must also comply with the minimum airflow of 300 cfm/ton according to the procedures specified in RA3.3.

Entirely new or complete replacement space-conditioning systems, as specified in §150.2(b)1C, must meet the minimum 350 cfm/ton airflow rate compliance criterion or the duct design alternative specified in §150.0(m)13.

2. **Thermostats.** When an existing system has a refrigerant containing component added or replaced, the thermostat must be upgraded to a digital setback type that meets §110.2(c)

G. System Replacements

See Chapter 4 for HVAC system replacement details for entirely new or complete replacements.

Prescriptive compliance requires new heating systems be limited to gas, propane, or the existing fuel type. The exception to this is a heat pump (§150.2(b)1G).

Example 9-30

Question:

Do I have to seal the ducts if I replace the outdoor units in my house without changing the indoor unit?

Answer:

Yes. Replacing the outdoor unit (or indoor unit) by itself will trigger the duct sealing and verification requirement. The alteration requirements differ from new construction requirements. (See §150.2(b)1Ei through iii for the requirements and exceptions.)

Example 9-31

Question:

I have an existing electric furnace and I'm adding a new bedroom. Can I extend the existing ducts to the new room and use the existing furnace?

Answer:

Yes. If ducts are extended from an existing space-conditioning system, §150.2(b)1Diib includes three options for showing prescriptive compliance when more than 40 feet of new duct work is installed. The existing furnace must have adequate heating capacity to meet California Building Code requirements for the additional space.

Example 9-32

Question:

I am adding a bedroom to a house that has a central forced-air natural gas furnace. I would like to heat the room with an electric resistance baseboard heater rather than extend the existing ductwork to reach the new space. Is this allowed?

Answer:

Not using prescriptive compliance. This is only possible if using performance compliance and the relatively high energy consumption of the electric resistance heater is made up by reductions from other energy efficiency measures in the addition or in an accompanying alteration.

Note: If there are more than 40 linear feet of added ducts, the ducts must be sealed, tested, and verified as sealed by a HERS Rater.

Example 9-33

Question:

My central gas furnace stopped working. If I get a new efficient unit rather than repair the existing one, what are the requirements?

Answer:

Mandatory requirements apply to the components being replaced. The furnace must meet minimum efficiency requirements, but all systems sold in California should already meet the minimum efficiency requirements. If the new system includes mechanical cooling, and the existing thermostat is not a setback thermostat, it must be replaced with a setback thermostat (§150.2(b)1Fi).

All new ducts must meet insulation and construction requirements. All existing and new ducts must be sealed and HERS-verified, as specified §150.2(b)1E.

Prescriptively, the new heating unit must be natural gas or a heat pump. A CF1R-ALT-02 or 03 form can be completed by you or your mechanical contractor. If HERS requirements apply this is done at the HERS Provider's web-site.

Example 9-34

Question:

As part of an upgrade in an existing house, one of the ducts is being replaced because of deterioration of the insulation. What requirements apply to the replacement duct?

Answer:

This is an alteration to the space-conditioning system; therefore, the mandatory measures for ducts apply. If more than 40 feet of the duct is altered, the requirements of §150.2(b)1D trigger diagnostic testing and HERS verification of the duct system.

Example 9-35

Question:

An upflow air-handling unit with a furnace and air conditioning coil is located on a platform in the garage of an existing house. The platform is used as a return air plenum. The air-handling unit is being replaced, and the platform is being repositioned to the corner of the garage (three feet away from the current location). What requirements apply to this alteration?

Answer:

The mandatory requirements apply to this alteration. In particular, §150.0(m) prohibits raised platforms or building cavities from being used to convey conditioned air (including return air and supply air). When the platform is relocated, it is being altered, and the mandatory requirement applies. Ducts made from sheet metal, duct board, or flexible ducts must be installed to carry the return air to the replaced air handler.

Since the air handler is being replaced the prescriptive duct sealing requirements of §150.2(b)1D and E, which apply to ducts in garage spaces, would require either 6 percent duct leakage or a visual inspection and smoke test. (See Section 9.4.6.1.)

Example 9-36

Question:

What is meant by the term "air handler"?

Answer:

The term "air handler" is used to identify the system component that provides the central system forced-air movement for the ducted heating or cooling space-conditioning system. The term "air handler" may be properly used to identify various types of central system forced-air-moving components that must meet the functional requirements for different types of space-conditioning systems. For instance, a "gas furnace" air handler includes a gas combustion heat exchanger and the central system fan, but does not include a direct expansion (DX) cooling coil; an "electric furnace" air handler has electric heating coils and the central system fan, but does not include a DX cooling coil; a "fan-coil unit" air handler for a split system heat pump has a DX cooling/heating coil and a central system fan; a "hydronic heat pump" air handler includes the air-side DX coil, compressor, water-cooled condenser, and the central system fan. There are other air handler configuration variations as well.

Example 9-37

Question:

I have a residential building that was constructed in the 1920s. It has a freestanding gas furnace, and I want to change it to an electric wall heater. Is this permitted?

Answer:

No. Section 150.2(b)1Cii states that the new space-conditioning system be limited to natural gas, liquefied petroleum gas, or the existing fuel type. The only electric option is a heat pump.

9.4.7 Mechanical Ventilation

The whole-building ventilation airflow requirement in ASHRAE 62.2 is required only in new buildings, new dwelling units, and buildings with additions greater than 1,000 ft². However, all other mechanical ventilation requirements in §150(o), including local exhaust, must be met, as applicable, in all additions and alterations.

If an addition to an existing building adds a new dwelling unit, indoor air quality requirements of §150.0(o) apply to the new dwelling unit (§150.2(a)1Cii).

When an addition is greater than 1,000 ft², the mechanical ventilation airflow rate is based on the conditioned floor area of the entire existing and new floor area of the dwelling unit (§150.2(a)1Ci).

When whole-building ventilation airflow is required for compliance, field verification and diagnostic testing of airflow performance are required in accordance with the procedures in Residential Appendix RA3.7. In that case, a Certificate of Compliance CF1R form must be registered online with a HERS Provider. (See Section 2.5 and Appendix A.)

9.4.8 Lighting Measures

Highlights of the residential lighting measures are listed below. All residential indoor and outdoor lighting measures are mandatory. Details of the 2019 Energy Standards residential lighting requirements can be found in Chapter 6.

1. Luminaire (light fixture) requirements, see §150.0(k)1, Section 6.2
2. Indoor lighting controls, see §150.0(k)2, Section 6.3
3. Lighting in bathrooms, garages, laundry rooms, and utility rooms, see §150.0(k)2J, Section 6.3.3
4. Recessed downlight fixtures, see §150.0(k)1C, Section 6.2.3
5. Outdoor lighting, see §150.0(k)3, Section 6.5
6. Internally illuminated address signs, see §150.0(k)4, Section 6.5.4
7. Residential garages for eight or more vehicles, see §150.0(k)5, Section 6.6
8. Interior common areas of low-rise multifamily buildings, see §150.0(k)6, Section 6.4

Altered lighting and any newly installed lighting equipment are required to comply with the residential lighting standards, which apply to permanently installed lighting and associated lighting controls.

Only the lighting equipment that is altered needs to comply with the Energy Standards. Existing lighting equipment is not required to be replaced to comply with the Energy Standards.

Example 9-38

Question:

I am doing minor renovations to my kitchen that has six recessed incandescent cans and I am adding a new luminaire over the sink. Does this luminaire have to be a high-efficacy luminaire?

Answer:

Yes, in kitchens, all new luminaires must be high-efficacy.

Example 9-39

Question:

In the kitchen above, I am replacing one of the recessed downlight luminaires. Must the new downlight luminaire be high-efficacy?

Answer:

Yes, newly installed luminaires must be high-efficacy and meet the requirements in §150.0(k). Screw-based sockets are not permitted for newly installed recessed downlight luminaires in ceilings.

Example 9-40

Question:

I am completely remodeling my kitchen and putting in an entirely new lighting system. How do the Energy Standards apply to this case?

Answer:

When an entirely new lighting system is installed, it is treated like new construction. The new lighting system must comply with all the mandatory lighting requirements in §150.0(k)1 and (k)2.

Example 9-41

Question:

I am replacing my incandescent bath bar in the bathroom. Must the new luminaire meet the Energy Standards requirements?

Answer:

The new luminaire is the altered component and must meet requirements in §150.0(k), including the high-efficacy luminaire and lighting control requirements. The 2019 Energy Standards now allow the installation of Joint Appendix JA8-compliant lamps in screw-based fixtures as a way to comply with the high-efficacy lighting requirements as long as the luminaire is not a recessed downlight in ceiling. See Sections 6.2 and 6.3 of this manual for details.

9.5 Performance Approach

9.5.1 Performance: Addition Alone

With very few exceptions, modeling an addition alone requires meeting the same requirements as new construction. Any exceptions for additions are explained in Sections 9.3.1 and 9.3.2.

9.5.2 Performance Method: Additions and Existing + Addition + Alterations Approach

The computer programs used for compliance include requirements from §150.2(a)2B as well as §150.2(b)2A and B to set the standard design budget. Table 9-12 contains the efficiencies used to establish the standard design for a building using existing + addition + alteration (which includes existing + alteration) compliance.

Table 9-12: Standard Design for Altered Components

Altered Component	Standard Design Without Third Party Verification of Existing Conditions Shall Be Based On	Standard Design With Third Party Verification of Existing Conditions Shall Be Based On
Ceiling Insulation, Wall Insulation, and Raised-Floor Insulation	The requirements of Sections 150.0(a), (c), and (d)	The existing insulation R-value
Fenestration	U-factor of 0.40 and SHGC value of 0.35. Glass area is existing glass area.	If proposed U-factor is ≤ 0.40 and SHGC value is ≤ 0.35 , standard design is existing U-factor and SHGC values, as verified. Otherwise, standard design is 0.40 U-factor and 0.35 SHGC. Glass area is existing glass area.
Window Film	U-factor of 0.40 and SHGC value of 0.35.	Existing fenestration based on Table 110.6-A and Table 110.6-B.
Doors	U-factor of 0.20. Door area is existing door area.	If proposed U-factor is < 0.20 , standard design is existing U-factor, as verified. Otherwise, standard design U-factor is 0.20. Door area is existing door area.
Space-Heating and Space-Cooling Equipment	TABLE 150.1-A or B for equipment efficiency requirements; Section 150.2(b)1C for entirely new or complete replacement systems; Section 150.2(b)1F for refrigerant charge verification requirements.	The existing efficiency levels.
Air Distribution System – Duct Sealing	The requirements of Sections 150.2(b)1D and 150.2(b)1E	
Air Distribution System – Duct Insulation	The proposed efficiency levels.	The existing efficiency levels.
Water Heating Systems	The requirements of Section 150.2(b)1H.	The existing efficiency level.
Roofing Products	The requirements of Section 150.2(b)1H.	
All Other Measures	Proposed efficiency levels.	Existing efficiency levels, as verified.
Source: Table 150.2-C, Energy Efficiency Standards.		

The table below summarizes the basic rules for modeling a low-rise residential building using the existing + addition + alterations performance approach. For more detailed information, see Section 9.7 or the software user manual.

Table 9-13: Modeling Rules for Existing + Addition + Alterations

Type of Component or System Modeled	Standard Design <i>Without</i> Third-Party Verification of Existing Conditions	Standard Design <i>With</i> Third-Party Verification of Existing Conditions
EXISTING – Components or systems to remain unchanged	Model each component or system as “Existing”	Model each component or system as “Existing”
ALTERED—Components or systems being changed or replaced	Model each altered component as “Altered” (prealtered conditions are not modeled)“	Model each altered component as “Altered” with prealtered conditions also modeled
NEW—Components or systems being added (did not previously exist)	Model each component or system as “New”	Model each component or system as “New”
REMOVED—Components or systems being removed and not replaced	These components omitted from the model	These components omitted from the model

1. **Without** third-party verification of the existing (prealteration) conditions of the building, the E+A+A approach provides credits only once a fairly high threshold is met. See §150.2(b)2B and Table 150.2-C of the Energy Standards.
2. **With** third-party verification of the pre-alteration conditions of the building, the E+A+A approach provides full credit for the effect of the altered component. See §150.2(b)2B and Table 150.2-C of the Energy Standards.

Energy Commission-approved compliance software is used to model the building as explained in Chapter 8 or the software user manual. Whichever compliance path is selected, the Certificate of Compliance (CF1R) generated by the software must be submitted for permit. If the CF1R includes energy measures that require HERS testing or verification, the CF1R must also be registered online with a HERS Provider before it is submitted for permit. See Chapter 2 of this manual.

9.5.3 Existing + Addition + Alterations Without Third-Party Verification

The existing building with all alterations is modeled together with the addition and **existing** conditions are not verified by a third-party HERS Rater. Under this performance path, the building is modeled as follows:

1. Addition: All new components of the addition and all new systems serving the addition are modeled, including roof/ceilings, skylights, exterior walls, glazing (fenestration), raised floors and slab floors, HVAC equipment, ducts, and water heating. Only HVAC equipment and water heating may be existing. All other components are “new.”

2. Existing Components to Remain Unchanged: Existing components and systems to remain are modeled and tagged within the compliance software as “existing.”
3. Existing Components to Be Altered or Replaced: Each altered component (i.e., a new component that replaces an existing component) is modeled as “altered.” For example, a new water heater that replaces an existing water heater is labeled “altered,” while a water heater that supplements an existing water heater is labeled “new.” Since verification of existing conditions is not being used, no “existing” conditions are specified.
4. Existing to Be Removed: These features are not modeled.

Note: Portions of new fenestration including skylights that will occur in the existing opening of fenestration to be replaced are tagged “altered.” Portions of new fenestration that will occur where there is no existing fenestration opening are labeled “new.”

9.5.4 Existing + Addition + Alterations With Third-Party Verification

The existing building with alterations is modeled together with the addition(s) in the same manner as above. Any altered components that are tagged to be verified by a third-party HERS Rater must be verified before permit application is made or construction begins. The standard design that sets the energy budget may, depending on the energy efficiency of the altered component or system, be based on the prealtered existing conditions.

9.5.5 Existing + Addition + Alterations as New Construction

A rarely used option is to model Existing + Addition + Alterations as all “new” components. The compliance software sets the energy budget as if the project were an entirely new building.

9.5.6 Summary of Modeling Rules

Table 9-13 summarizes the basic rules for compliance software users analyzing a residential addition or alteration using the Existing + Addition + Alterations approach. For further information, see the specific compliance software user's manual for details on how to input data correctly.

Example 9-42

Question:

A 1,600 ft² house built in 1980 in Climate Zone 12 is being renovated as follows:

1. A 500 ft² room will be added, including 120 ft² of new windows.
2. A 200 ft² wall and 100 ft² of old window will be removed.
3. Attic insulation in the existing house will be upgraded to R-38.
4. The addition will be connected to the existing HVAC and duct system.

If the performance approach is used to demonstrate compliance, how does the compliance software establish the standard and proposed designs?

Answer:

Table 9-13 summarizes the Modeling Rules for Existing + Addition + Alterations, which must be followed to have the compliance software accurately set the standard design and model the proposed design. Under the 2019 standards performance rules, the removed wall and window are not included in the energy model and have no effect. The standard design for the added conditioned floor area is set using the prescriptive requirements of §150.1(c). If the existing duct system is extended by 40 linear feet or more, the standard design assumes duct alterations with 15 percent duct leakage requirements.

The standard design assumptions for the existing house follow the rules summarized in §150.2(b)2 and Table 150.2-C based on whether there is third-party verification of the existing conditions. Without third-party verification, upgraded energy components in the existing house are modeled as fixed assumptions that represent reasonably expected levels of efficiency for each altered component. If optional third-party verification is selected for the components in the existing house that are to be upgraded, the standard design assumes the existing conditions specified by the software user. These features must be verified before construction begins and before application of the permit.

The standard design assumptions for the 500 ft² addition is based on the features of §150.1(c), Table 150.1-A.

The existing space conditioning system, as defined by the software user, is modeled in both the standard and proposed design. The duct system is made up of new ducts as an extension of the existing ducts.

Example 9-43

Question:

For the 1980 house in the examples above, an operable single-pane metal window is replaced with a 0.55 U-factor window. Does this alteration result in a compliance credit? How about the case where the existing window is replaced with a window that has a U-factor of 0.35?

Answer:

As explained in Example 9-42, altered components that receive compliance credit must exceed the requirements of Table 150.2-C. Windows in the addition must have a U-factor of ≤ 0.30 and SHGC ≤ 0.23 to receive credit (Climate Zone 12). Replacement windows in the existing house must have a U-factor of ≤ 0.40 and SHGC ≤ 0.35 to receive credit.

A window replacement with a 0.55 U-factor will receive a penalty compared with a 0.40 U-factor standard design assumption for that window. **Without** third-party verification of existing conditions, a 0.35 U-factor window replacement will receive a credit compared with a 0.40 U-factor standard design assumption for that window. **With** third-party verification of existing conditions, either window replacement will receive a credit as compared with a 1.28 U-factor standard design assumption for an operable single-pane metal existing window.

Although this example describes a window alteration, the same principles apply to other building systems, such as other building envelope components, as well as HVAC and water-heating equipment.

Example 9-44

Question:

An addition of 590 ft² is being added to a 2,389 ft² single-family house. How do you demonstrate compliance using the Existing + Addition + Alterations method?

Answer:

The steps are the following:

1. Collect accurate envelope and mechanical information about the addition and existing building from scaled drawings (plans, sections, and elevations); determine what components, (HVAC, ducts, water heating, etc.) are being altered as part of the permitted scope of work.
2. Enter the information about the addition and the existing building into the compliance software program, identifying each modeled feature as “existing,” “altered,” or “new,” as summarized in Table 9-13. Proper identification of these inputs is critical to correctly and accurately determining compliance.
3. Run the compliance software to determine if the proposed building TDV energy is equal or less than the standard design TDV energy.
4. If the project does not comply, modify the energy features of the addition and/or the existing building until compliance is achieved.
5. If features of the existing building are being modified, consider the option of verifying existing conditions. When using this option, this inspection by a HERS Rater must be completed before construction begins and before the project registration (Step 6) can be completed.
6. All projects that include energy measures requiring HERS field verification and diagnostic testing--which represent almost all buildings under the 2019 Energy Standards--must be registered online with a HERS Provider as explained in Section 2.3 in order to obtain a valid CF1R to apply for a permit.
7. Print the registered CF1R for permit application submittal.

Example 9-45

Question:

When using the existing-plus-addition performance approach, do the mandatory requirements, including airflow, watt draw measurement, etc. (§150.0(m)13) need to be met for space-conditioning equipment serving an addition? What about the prescriptive requirement for refrigerant charge verification (or one of the alternatives to §150.1(c)7)?

Answer:

If existing equipment is extended to serve the addition, these space conditioning requirements do not need to be met as specified by Exception 4 to §150.2(a). However, Exception 5 to §150.2(a) requires a duct system that is extended be sealed, tested, and HERS verified according to §150.2(b)1D.

If an entirely new or complete replacement system is installed to serve the addition, it must meet the requirements of §150.2(b)1C. When the new equipment is designed to serve the existing house and the addition, it is an alteration and must meet the requirements of §150.2(b). The duct sealing, testing, and verification requirements of §150.2(b)1E must also be met. Refrigerant charge verification is not a mandatory requirement. However, if the project is in Climate Zone 2 or 8-15, there is a compliance penalty if refrigerant charge verification is not modeled.

Example 9-46

Question:

When using the E+A+A performance method, can compliance credit be gained by sealing the existing ducts when it was not required for prescriptive compliance?

Answer:

No. Once the status of the ducts is “altered” the standard design assumes the duct sealing is required.

Example 9-47

Question:

When using the existing-plus-addition performance compliance method, can credit be gained by installing a radiant barrier in the existing house attic?

Answer:

No. Once the attic/roof is “altered” the standard design becomes equivalent to Table 150.1-A or B

Example 9-48

Question:

I am adding a room to and altering an existing building in Climate Zone 12. I am upgrading an existing single-pane clear glass window with a U-factor of 1.2 and SHGC of 1.0 to a dual-pane window with a U-factor of 0.50 and SHGC of 0.45. Do I receive credit toward the addition compliance for installing this window?

Answer:

No, Without third-party verification of the existing building features, there will be a penalty toward achieving compliance since the window is not as efficient as required by Table 150.2-C for Climate Zone 12, which requires a U-factor of 0.40 and an SHGC of 0.35. The penalty for the U-factor is based on the difference between 0.40 and 0.50 and for the SHGC is based on the difference between 0.35 and 0.45. If fenestration is installed that exceeds the performance of the values in Table 150.2-C, then credit is available.

Example 9-49

Question:

I am planning to install R-19 insulation in the attic of an existing house built in 1970. Can I use this added insulation as a credit for trading with the energy features of an addition?

Answer:

No. When insulation is added to an attic, it must comply with §150.0(a), which sets a mandatory minimum for attic insulation of R-22. Since R-22 is a mandatory minimum a lower insulation cannot be installed.

Example 9-50

Question:

I am planning to install R-25 insulation in an uninsulated vaulted ceiling without an attic space in an existing house built in 1970. Can I use this added insulation as a credit for trading with the energy features of an addition?

Answer:

Only if you choose verified existing conditions (see Example 9-44) and even then it will depend on the climate zone. Because the prescriptive approach has no provision for vaulted roofs, once the roof is altered, the standard design becomes an attic/roof meeting Option B. If Option B has no below roof deck insulation, it is possible to get credit for insulating an uninsulated vaulted roof to R-25.

Appendix A Compliance Documents

NOTE: For Documents and User Instructions, please visit our website at:
<https://www.energy.ca.gov/programs-and-topics/programs/building-energy-efficiency-standards/2019-building-energy-efficiency>

Doc Type	Doc Category	Category Description	Document Description
CF1R's – Certificate of Compliance			
CF1R-	ADD-01-E	Additions	Prescriptive Additions Less Than 1,000 ft ²
CF1R-	ADD-02-E	Additions	Prescriptive Additions – Simple NonHERS (paper version)
CF1R-	ALT-01-E	Alterations	Prescriptive Alterations
CF1R-	ALT-02-E	Alterations	Prescriptive Alterations HVAC
CF1R-	ALT-05-E	Alterations	Prescriptive Alterations – Simple NonHERS (paper version)
CF1R-	ENV-02-E	Envelope	Area Weighted Average Calculation Worksheet
CF1R-	ENV-03-E	Envelope	Solar Heat Gain Coefficient (SHGC) Worksheet
CF1R-	ENV-04-E	Envelope	Solar Reflective Index (SRI) Worksheet
CF1R-	ENV-05-E	Envelope	Alternative Default Fenestration Procedure (NA6) Worksheet
CF1R-	ENV-06-E	Envelope	Interior and Exterior Insulation Layers Worksheet
CF1R-	NCB-01-E	Newly Constructed Buildings	Prescriptive Newly Constructed Buildings and Additions Equal to or Greater Than 1,000 ft ²
CF1R-	PLB-01-E	Plumbing (DHW)	Hydronic Heating System Worksheet
CF1R-	PRF-01-E	Performance	Residential Performance Compliance Method
CF1R-	STH-01-E	Solar Thermal	OG 100 Solar Water Heating Worksheet
CF2R's – Certificate of Installation			
CF2R-	ADD-02-E	Additions	Prescriptive Additions – Simple NonHERS (paper version)
CF2R-	ALT-05-E	Alterations	Prescriptive Alterations – Simple NonHERS (paper version)
CF2R-	ENV-01-E	Envelope-NonHERS	Fenestration Installation
CF2R-	ENV-03-E	Envelope-NonHERS	Insulation Installation

Appendix A Compliance Documents

Doc Type	Doc Category	Category Description	Document Description
CF2R-	ENV-04-E	Envelope-NonHERS	Roofing – Radiant Barrier
CF2R-	ENV-20-H	Envelope-HERS	Building Leakage Diagnostic Test
CF2R-	ENV-21-H	Envelope-HERS	QII - Framing Stage
CF2R-	ENV-22-H	Envelope-HERS	QII – Insulation Installation Stage
CF2R-	LTG-01-E	Lighting-NonHERS	Lighting - Single Family Dwellings
CF2R-	LTG-02-E	Lighting-NonHERS	Lighting - Multifamily Dwellings
CF2R-	MCH-01-E	Mechanical-NonHERS	Space Conditioning Systems
CF2R-	MCH-02-E	Mechanical-NonHERS	Whole House Fan
CF2R-	MCH-04-E	Mechanical-NonHERS	Evaporative Coolers
CF2R-	MCH-20-H	Mechanical-HERS	Duct Leakage Diagnostic Test
CF2R-	MCH-21-H	Mechanical-HERS	Duct Location Verification
CF2R-	MCH-22-H	Mechanical-HERS	Fan Efficacy
CF2R-	MCH-23-H	Mechanical-HERS	Airflow Rate
CF2R-	MCH-24-H	Envelope-HERS	Building Envelope Air Leakage Worksheet
CF2R-	MCH-25-H	Mechanical-HERS	Refrigerant Charge Verification
CF2R-	MCH-26-H	Mechanical-HERS	Rated Space Conditioning System Equipment Verification
CF2R-	MCH-27-H	Mechanical-HERS	Indoor Air Quality and Mechanical Ventilation
CF2R-	MCH-28-H	Mechanical-HERS	Return Duct Design and Air Filter Grille Device Sizing According to Tables 150.0-B or C
CF2R-	MCH-29-H	Mechanical-HERS	Duct Surface Area Reduction; R-Value; Buried Ducts Compliance Credit
CF2R-	MCH-30-E	Mechanical-HERS	Ventilation cooling compliance credit
CF2R-	MCH-31-H	Mechanical-HERS	HERS Verified Whole House Fan
CF2R	MCH-32-H	Mechanical-HERS	Kitchen Ventilation

Doc Type	Doc Category	Category Description	Document Description
CF2R-	PLB-01-E	Plumbing-DHW-NonHERS	Multifamily Central Hot Water System Distribution
CF2R-	PLB-02-E	Plumbing (DHW)-NonHERS	Single Dwelling Unit Hot Water System Distribution
CF2R-	PLB-03-E	Plumbing (DHW)-NonHERS	Pool and Spa Heating Systems
CF2R-	PLB-21-H	Plumbing (DHW)-HERS	HERS Verified Multifamily Central Hot Water System Distribution
CF2R-	PLB-22-H	Plumbing (DHW)-HERS	HERS Verified Single Dwelling Unit Hot Water System Distribution
CF2R-	PVB-01-E	Photovoltaics-NonHERS	Photovoltaic Systems
CF2R-	PVB-02-E	Photovoltaics-NonHERS	Battery Storage Systems
CF2R-	SRA-01-E	Solar Ready	Solar Ready Areas
CF2R-	SRA-02-E	Solar Ready	Minimum Solar Zone Area Worksheet
CF2R-	STH-01-E	Solar Thermal	Solar Water Heating Systems
CF3R's – Certificate of Installation			
CF3R-	ENV-20-H	Envelope-HERS	Building Leakage Diagnostic Test
CF3R-	ENV-21-H	Envelope-HERS	QII - Framing Stage
CF3R-	ENV-22-H	Envelope-HERS	QII – Insulation Installation Stage
CF3R-	EXC-20-H	Existing Conditions	HERS Verification of Existing Conditions for Residential Alterations
CF3R-	MCH-20-H	Mechanical-HERS	Duct Leakage Diagnostic Test
CF3R-	MCH-21-H	Mechanical-HERS	Duct Location Verification
CF3R-	MCH-22-H	Mechanical-HERS	Fan Efficacy
CF3R-	MCH-23-H	Mechanical-HERS	Airflow Rate
CF3R-	MCH-24-H	Envelope-HERS	Building Envelope Air Leakage Worksheet
CF3R-	MCH-25-H	Mechanical-HERS	Refrigerant Charge Verification
CF3R-	MCH-26-H	Mechanical-HERS	Rated Space Conditioning System Equipment Verification
CF3R-	MCH-27-H	Mechanical-HERS	Indoor Air Quality and Mechanical Ventilation

Appendix A Compliance Documents

Doc Type	Doc Category	Category Description	Document Description
CF3R-	MCH-28-H	Mechanical-HERS	Return Duct Design and Air Filter Device Sizing According to Tables 150.0-B or C
CF3R-	MCH-29-H	Mechanical-HERS	Duct Surface Area Reduction; R-value; Buried Ducts Compliance Credit
CF3R-	MCH-31-H	Mechanical-HERS	HERS Verified Whole House Fan
CF3R-	MCH-31-H	Mechanical-HERS	Kitchen Ventilation
CF3R-	PLB-21-H	Plumbing (DHW)-HERS	HERS Verified Multifamily Central Hot Water System Distribution
CF3R-	PLB-22-H	Plumbing (DHW)-HERS	HERS Verified High Rise Residential/Hotel/Motel Single Dwelling Unit Hot Water System Distribution
NRCV-	MCH-04-H	Mechanical-HERS	Duct Leakage Diagnostic Test
NRCV-	MCH-24-H	Mechanical-HERS	Building Envelope Air Leakage Worksheet
NRCV-	MCH-27-H	Mechanical-HERS	Indoor Air Quality and Mechanical Ventilation
NRCV-	PLB-21-H	Plumbing (DHW)-HERS	HERS Verified Multifamily Central Hot Water System Distribution
NRCV-	PLB-22-H	Plumbing (DHW)-HERS	HERS Verified High Rise Residential/Hotel/Motel Single Dwelling Unit Hot Water System Distribution

Appendix B

All energy calculations used for compliance with the Standards must use the climate zone applicable to a building project is determined based on its physical location as it relates to the determinations of climate regions found in the Commission publication California Climate Zone Descriptions, which contains detailed survey definitions of the 16 climate zones.

The list of climate zone areas by ZIP code is located on the CEC website here:

http://www.energy.ca.gov/maps/renewable/building_climate_zones.html

CEC has also developed an interactive climate zone lookup tool that allow user to locate climate zone by address or ZIP code. The lookup tool is located here:

<http://caenergy.maps.arcgis.com/apps/webappviewer/index.html?id=4831772c00eb4f729924167244bbca22>

FIGURE 100.1-A—CALIFORNIA CLIMATE ZONES

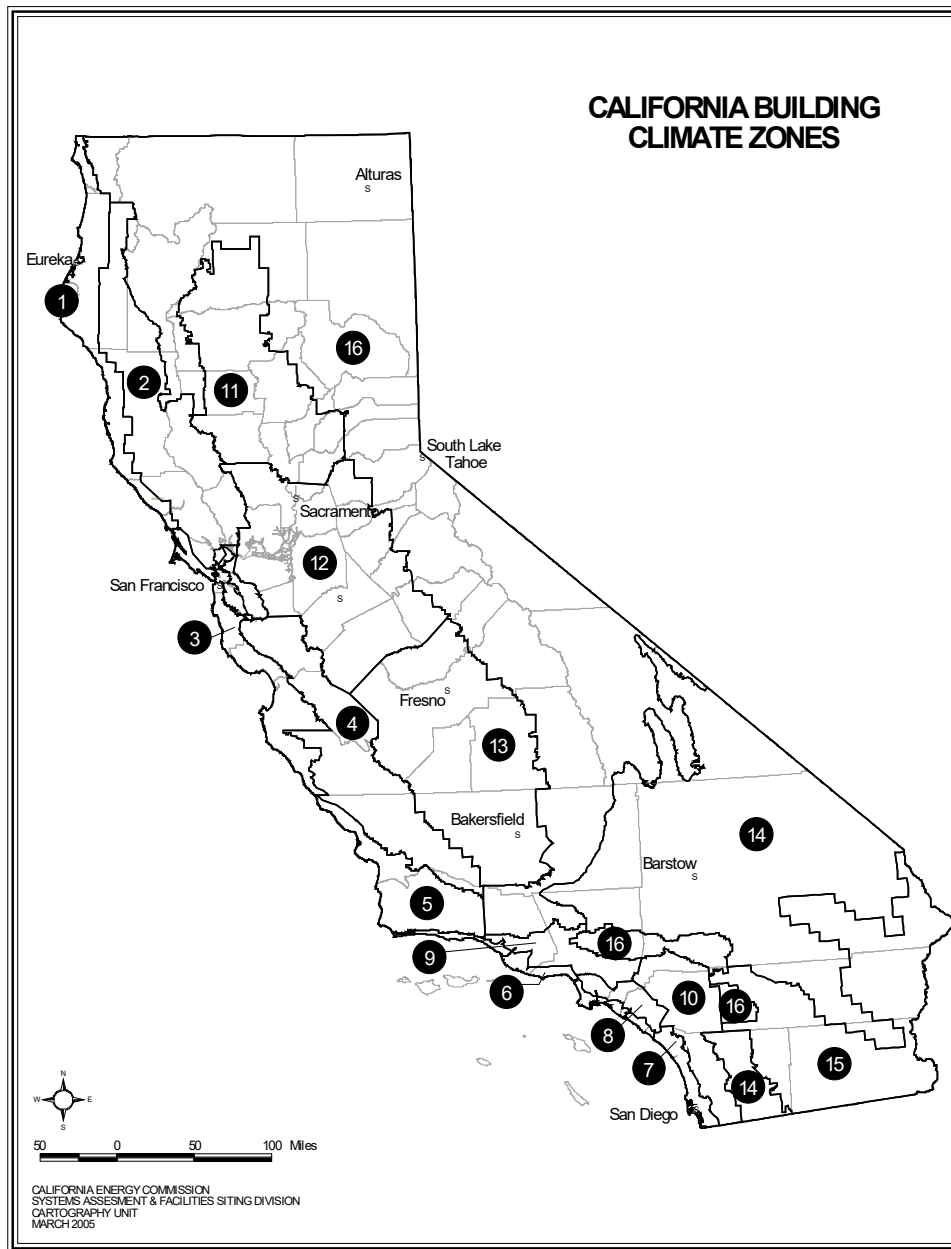

Table of Contents

C1	Housing Affordability	1
C2	Photovoltaic Costs.....	2
C3	Photovoltaic System Maintenance Costs	3
C4	Photovoltaic Mandate.....	3
C5	Rooftop Solar Vs Utility-Scale System	4
C6	Excess midday solar capacity	5
C7	Statewide Electricity Rate Assumptions	7
C8	Solar System Lifespan	7
C9	Emissions Reduction Benefits	8
C10	Net Energy Metering and Cost Effectiveness.....	9
C11	Battery Storage Benefits	9
C12	Stakeholder Inputs	10
C13	References.....	10

Appendix C

Frequently Asked Questions on Housing Affordability, Photovoltaic, Community Shared Solar, and Battery Storage

C1 Housing Affordability

Question

On the average, the new PV requirements will add about \$8,400 to the cost of a single-family home. Wouldn't that make homeownership less affordable at a time where California's home prices are already out of reach?

Answer

No. A home with solar costs less to own than one without. Put another way, the benefits of solar outweigh its costs, such that the new homeowner is saving money from day one in the home. That family will save thousands of dollars over the first decade of ownership.

Home affordability includes both the first cost and operating costs, which include utility bills. The PV requirement actually makes homeownership more affordable: the reduction in energy bills exceeds the corresponding increase in mortgage payment by around \$35 per month on average.

If first cost is a primary concern – as it is for many including young families and first-time home buyers – the cost of PV need not be covered by the home price or mortgage principal. PV options are already today routinely leased instead of purchased outright. Leased PV systems have little or no upfront costs, and offer up to 20 percent electric bill savings; thus the same logic as above applies. In the future, community-shared solar options may also be available as an alternative to onsite PV systems, with little or no upfront costs.

C2 Photovoltaic Costs

Question

What is the basis for the Energy Commission’s \$3.10 photovoltaic (PV) installed cost by 2020, and what is the evidence that the PV prices are continuing to drop?

Answer

The Energy Commission used three sources to establish the cost for newly constructed residential PV system installations. The primary source of cost information was the National Renewable Energy Laboratory (NREL) report titled U.S. Solar Photovoltaic System Cost Benchmark: Q1 2017. NREL estimated an installation cost of \$2.80 in Q1 2017. The complete report is located at: <https://www.nrel.gov/docs/fy17osti/68925.pdf>.

To corroborate these cost estimates, the Energy Commission also examined cost data from the Solar Energy Industries Association (SEIA). SEIA data track installed PV costs in all 50 states, including California. SEIA estimated an installation cost of \$2.94 in Q4 2017.

Finally, the Energy Commission considered the California New Solar Home Partnership (NSHP) program data, which include thousands of California new construction installations since 2015. The table below summarizes the findings based on the most recent NSHP data.

2015-2018 NSHP PV Installation Costs for New Buildings							
Year	Number of Systems Installed	Median PV Size, kilowatt (kW)	Average PV Size, kW	Median Cost/Watt	% Reduction, Median	Average Cost/Watt	% Reduction, Average
2015	7,150	2.6	3.0	\$4.85	0%	\$4.82	0%
2016	5,924	2.7	3.3	\$4.31	11%	\$4.30	11%
2017	7,973	2.7	3.2	\$3.58	26%	\$3.98	17%
2018	2,922	2.7	2.9	\$3.00	38%	\$3.66	24%

The NSHP data also indicate that the downward trend for PV prices is continuing at a strong pace through mid-2018. These data also show that the Energy Commission's assumed \$3-per-watt average for the installed cost of PV systems in newly constructed buildings is in keeping with the current PV price trends.

The Energy Commission projections are conservative. The PV requirement will remove many of the "soft costs" of the PV market, such as customer acquisition costs and customer-specific design, which can be significant. Bulk equipment procurement and factory-like installation (similar to windows and roofing) in a "production build" housing development are highly likely to reduce costs to well below Commission estimates by 2020.

C3 Photovoltaic System Maintenance Costs

Question

Did the Energy Commission's PV cost-effectiveness study consider the system maintenance costs and replacement costs for inverters and battery storage systems?

Answer

Yes, the Energy Commission included maintenance and inverter replacement costs in its life-cycle costing analysis. PV panels do not require much maintenance; however, the Commission assumed \$0.02 per kilowatt-hour (kWh) for maintenance cost and assumed two inverter replacements at the beginning of years 11 and 21. The present value of these costs were added to the upfront cost of the PV system, yielding a total system present value of \$3.10 per watt for 2020.

The Energy Commission did not consider battery storage replacement costs because these devices are not prescriptive requirements and are optional under the 2019 Standards.

C4 Photovoltaic Mandate

Question

The 2019 PV requirements are often referred to as the "PV mandate." Is this requirement truly a mandate?

Answer

The word "mandate" does not precisely describe the 2019 Standards PV requirement, as it implies a rigid and inflexible set of requirements. Builder and homeowner choice and flexibility are essential parts of the building energy efficiency standards approach. Builders can use more energy efficiency, demand-responsive measures, thermal storage, and battery storage technologies to reduce the PV size by 40 percent or more, while maximizing the benefits to the homeowners, the grid, and the environment. If first costs are the main concern, PV lease arrangements with little or no upfront cost may be used to comply with the energy standards PV requirements. In the future, when approved by the Energy

Commission, community-shared solar options may be an alternative to onsite PV systems. Exceptions to the PV requirement exist for specific instances in which a house may be built in an area of insufficient solar availability or where electricity rates are uncommonly low.

C5 Rooftop Solar Vs Utility-Scale System

Question

The larger utility-scale PV systems cost about half as much as onsite PV systems. Would it be more cost-effective to achieve the state's policy goals with the less expensive utility-scale PV systems?

Answer

The state is pursuing a diverse set of energy and environmental policies to simultaneously save energy and reduce greenhouse gas emissions, including:

- Reducing greenhouse gas emissions from all sectors, including buildings and transportation.
- Maintaining grid reliability and resilience.
- Achieving cost-effective energy savings in buildings.

To achieve these policy goals, the state must use all available options, including utility-scale and onsite PV systems. These approaches are complementary and not mutually exclusive. Both options reduce carbon dioxide (CO₂) emissions, and present unique opportunities, challenges, and environmental benefits:

- **Utility-scale PV systems** may be up to 500 megawatts (MW) or larger. The benefits include installed equipment costs that are less expensive per watt (\$1.05 to \$1.20 per watt) than an onsite rooftop system, and reduced system-wide CO₂ emissions. The challenges include acquiring large plots of land, long transmission, distribution, and transformer infrastructure; and time consuming, and expensive environmental impact reports. The systems can also negatively impact sensitive wildlife habitats. It is important to include all costs and challenges when comparing a utility-scale PV system to onsite solar.
- **Onsite or rooftop PV systems** are generally only a few kW. The installed equipment costs are around \$3 per watt. The benefits of these systems are that they do contribute to CO₂ reduction from building loads, they do not require land acquisition (the roof is existing and available for PV deployment at no additional cost) or additional transmission and distribution infrastructure because the system is close to the load it serves. As part of a local distributed energy resource (DER) system and because of the proximity to the loads it serves, an onsite PV system, once coupled with smart inverters, demand response, and a battery storage system, can enhance grid reliability and resilience. The benefits of a DER system include providing ancillary services (frequency and voltage regulation) and improved reliability during grid failures, natural disasters, and wildfires. Further, the distributed nature of small generation systems reduces the grid's overall vulnerability to cyberattacks. Onsite efficiency and PV systems

allow building occupants to save each month on their utility bills, making home ownership more affordable.

Importantly, the 2019 Standards allow community-scale PV as an alternative renewable resource to onsite PV systems, when approved by the Energy Commission. Community-scale PV systems can range from a few kW to a few MW. The equipment costs for these systems are even lower than rooftop, in the \$2-per-watt range. Plans for community solar may face unique barriers such as limitations of the compensation model. Some community solar options may also require land acquisition, and distribution infrastructure development.

C6 Excess midday solar capacity

Question

Would the 2019 Standards PV requirement create or exacerbate a market where California has too much solar capacity on mild and sunny days?

Answer

The expected increase in PV installations due to the 2019 Standards PV requirement is equal to only 1.1 percent of total existing statewide PV capacity. The other 98.9 percent of the PV capacity installed in the state—including utility-scale PV systems, nonresidential buildings installations, and PV installed on existing homes—is unaffected by the new requirements. Further, because the rate of growth for utility-scale and voluntary, behind-the-meter capacities is steeper than the residential new construction rate, residential new construction will make up a smaller percentage of total statewide PV capacity in the future.

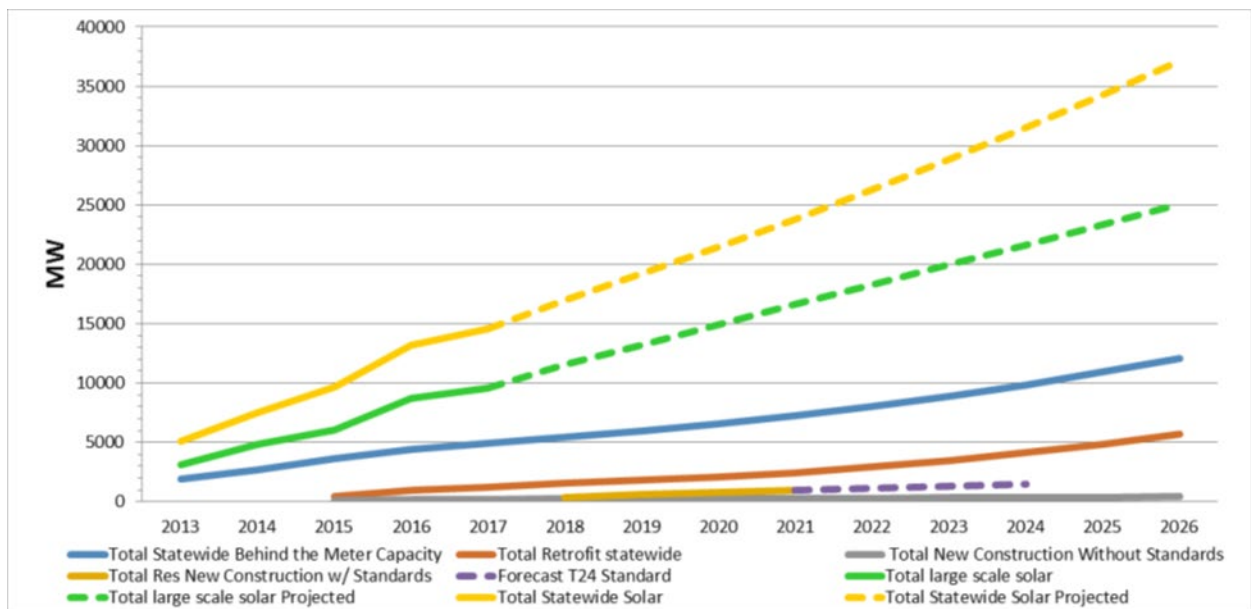

Moreover, the 2019 Standards require PV systems sized to offset just the annual electricity consumption of a highly efficient dual-fuel home. The result is a modest PV size (2.8 kW for a typical single-family house) when compared to the average PV size installed on existing homes (about 7.2 kW for a typical single-family home). PV for existing homes is unaffected by the 2019 Standards.

Overgeneration that causes a homeowner to sell electricity back to the grid is discouraged by both net energy metering rules and by the 2019 Standards.

The 2019 Standards include compliance incentives for demand response and grid-harmonization measures, such as precooling, thermal storage, and battery storage systems. These complementary technologies maximize self-utilization of PV electricity generated onsite and minimize hourly exports back to the grid, and as they come into common use, they will benefit distribution systems and enhance local reliability.

C7 Statewide Electricity Rate Assumptions

Question

The Energy Commission assumed an average statewide residential retail rate of 18 cents per kWh to calculate the monthly energy bill savings of \$80. What assumptions did the Energy Commission make to reach this number?

Answer

The Energy Commission conservatively chose 18 cents per kWh by considering the residential rates of several utilities, including Pacific Gas & Electric (PG&E), Southern California Edison (SCE), San Diego Gas & Electric (SDG&E), and Los Angeles Department of Water and Power (LADWP). Together, these utilities cover about 90 percent of the state’s ratepayers. The following table summarizes these rates for each utility.

2018 Residential Flat Rates. Cents per kWh				
Tier	PG&E - Schedule E1, EM	SCE - Schedule D	SDG&E - Summer, Schedule DR	LADWP - June, Schedule R1
Base	21.1	17.5	27	15.5
Mid-Tier	27.9	24.7	47	19.6
High-Tier	43.3	34.5	55	26.4
Average	25.3	20.9	33.5	17.7

Given these data, it appears that the Energy Commission’s estimate of statewide average electricity cost of 18 cents/kWh is on the low side. If the actual rates are higher than 18 cents per kWh, then savings will be even greater for the utility customer.

C8 Solar System Lifespan

Question

Why did the Energy Commission use a lifespan of 30 years for PV panels instead of 25 years?

Answer

The National Renewable Energy Laboratory (NREL), SunPower, Solar City, and other manufacturers support a 30-year or longer lifespan for PV panels. Although most panel warranties through the manufacturers are 20 to 25 years, the expected lifespan is longer. A warranty and the lifespan of a panel are not the same thing.

C9 Emissions Reduction Benefits

Question

How did the Energy Commission calculate the emissions reduction benefits of the 2019 Standards and the PV requirements? Did Energy Commission consider the impact of midday “renewable curtailment” on CO2 emissions? California’s long-term policies require the energy grid to use more renewable resources, essentially making the grid greener. Do the new onsite PV requirements reduce CO2 emissions despite these policies?

Answer

Yes. The Energy Commission uses a detailed hourly simulation model, known as CBECC-Res, to determine energy savings and emission impacts of the 2019 Standards. For every hour of the year, the software tracks all house loads (HVAC, water heating, plug loads, appliances, lighting, and so forth) and PV generation. Based on these hourly calculations, the software calculates PV-generated kWh that serve the house loads (which reduces the kWh that is purchased from the grid), and the hourly exports back to the grid. Next, the software applies California hourly long-term marginal emission rates to the hourly kWh balances to calculate the CO2 generation impact for each hour of the year. Finally, the software adds all the hourly results to yield the annual CO2 reduction benefits.

Overabundance of PV resources can occasionally cause the grid operators to “curtail renewables” midday on some mild and sunny days; the California long-term marginal emission rates consider the impacts of “renewable curtailment” on the grid.

The 2019 Standards PV requirements will reduce building-based CO2 emissions significantly, even considering the Renewables Portfolio Standard (RPS) goal of 50 percent by 2020 for California grid, as indicated in the table below. Over the longer term, the PV requirement will help California reach the newly-established 100 percent clean energy goal.

Prototype home: 2,700 sf, Climate Zone 12 – Sacramento, CA		
CO2 Impact of Housing Choices		Metric Tons of CO2 Generated/Year
Mixed-fuel	1997 Standards, no PV	6.5
Mixed-fuel	2019 Standards, no PV	3.1
Mixed-fuel	2019 Standards, with 3.1 kW PV	2.3
All-electric	2019 Standards, 3.1 kW PV, no battery	1.1
All-electric	2019 Standards, 6 kW PV, with battery	0.2

During the three-year cycle of the 2019 Residential Standards, CO2 emissions will be reduced by 700,000 metric tons, equivalent to taking 115,000 18-miles-per-gallon gas cars off the roads.

Further, the 2019 Standards compliance incentives for demand response and grid harmonization measures, such as precooling, thermal storage, and battery storage systems, can make the house invisible to the grid during most hours of the day, resulting in little or no CO2 emissions.

C10 Net Energy Metering and Cost Effectiveness

Question

The Energy Commission used only the current net energy metering, known as NEM2, rules to determine cost effectiveness for the onsite PV systems. NEM2 will be up for review by the California Public Utilities Commission (CPUC) in 2019. Did the Energy Commission consider alternatives to the current NEM2 policy?

Answer

Yes, the Energy Commission examined three net energy metering scenarios: (1) the current NEM 2.0 systems; (2) an alternative that significantly reduces bill savings for PV hourly exports to the grid (avoided cost instead of retail cost); and (3) a case where all generation is credited only with avoided costs – a highly unlikely scenario. Under the first two scenarios, all systems were cost effective by large margins. Under the third scenario, PV passed the cost test in 5 of 16 climate zones and narrowly failed in the others.

C11 Battery Storage Benefits

Question

When batteries are used, there is a loss of electricity associated with the roundtrip charge and discharge, resulting in fewer generated kWh. Why does the Commission provide a compliance credit for a battery storage system that is coupled with a PV system if there is a loss of energy?

Answer

Battery storage systems store the PV generated electricity in the middle of the day when solar resources are generally plentiful and electricity prices are low. The system discharges the stored electricity later in the day, during peak hours when solar resources are diminished and electricity prices are high. Battery storage systems have a roundtrip charge and discharge loss of 5 to 15 percent, depending on the type of battery technology and the inverter efficiencies. A compliance credit is available because the electricity price differential between the middle of the day and peak hours is greater than the battery charge and discharge losses. This means that even with the relatively small loss of electricity, it is still cost effective for a consumer to store electricity generated onsite around midday and use it later on instead of purchasing additional electricity from the grid.

To calculate the compliance credit of a battery storage system coupled with a PV system, the Energy Commission’s compliance software on an hourly-basis accounts for the PV generation, losses, storage capacity remaining, charge and discharge rates, cost of electricity, house loads, and hourly exports. Similar calculations are also performed to calculate the benefits of storage for CO2 emissions.

Not all battery storage systems are eligible for compliance credit; the system must comply with the requirements of Reference Joint Appendix 12 (See References). These requirements ensure that the battery storage system operates in a way that allows residents to take advantage of variable electricity costs associated with periods of clean energy availability throughout the day. Static batteries that remain mostly in backup mode have little to no value to the homeowner, the grid, or the environment.

C12 Stakeholder Inputs

Question

Did the Energy Commission receive any stakeholder input on these requirements? Were stakeholders aware of the Energy Commission’s proposal?

Answer

Zero-net-energy goals have been part of California’s *Energy Efficiency Strategic Plan*¹ since 2008; the 2013, 2016, and 2019 updates to Part 6 have consistently and transparently worked toward these goals. The 2019 rulemaking was preceded by 10 utility-hosted and 14 Energy Commission-hosted workshops and public hearings over 15 months. Hundreds of participants provided thousands of comments, to each of which the Energy Commission responded during the 2019 rulemaking process. Participants included California Building Industry Association (CBIA), Solar Energy Industries Association (SEIA), California Energy Storage Alliance (CESA), Bay Area Regional Energy Network (BayREN) representing local jurisdictions, investor-owned utilities, municipal utilities, community-shared solar and renewables advocates, environmental advocates, solar PV and battery storage manufacturers, the California Public Utilities Commission (CPUC), the California Air Resources Board (CARB), and members of the public, among others. All events were publicly noticed weeks in advance, and relevant information was emailed to thousands of subscribers on the Energy Commission’s Building Standards listserv.

C13 References

E3 PV cost-effectiveness report for the *2019 Building Energy Efficiency Standards. Measure Proposal Rooftop Solar PV Systems*. 2018.

¹ <http://www.cpuc.ca.gov/General.aspx?id=4125>

<http://www.energy.ca.gov/title24/2019standards/rulemaking/documents/code-proposal-reports/index.php>

National Renewable Energy Labs (NREL). *U.S. Solar Photovoltaic System Cost Benchmark: Q1 2017*. 2017.

<https://www.nrel.gov/docs/fy17osti/68925.pdf>

Lawrence Berkeley National Labs (LBNL). *Tracking the Sun10*. 2017.

<https://emp.lbl.gov/publications/tracking-sun-10-installed-price>

[California New Solar Home Partnership Program \(NSHP\) 2015-2018 Data:](#)

<https://www.newsolarhomes.org/WebPages/Public/Reports.aspx>

[Energy Commission Energy Efficiency Listservs - Self-Subscribing/Unsubscribing:](#)

<https://www.energy.ca.gov/efficiency/listservers.html>

Pacific Gas & Electric 2018 Residential Rates:

<https://www.pge.com/tariffs/electric.shtml>

Southern California Edison 2018 Residential Rates:

<https://www.sce.com/wps/portal/home/residential/rates/Standard-Residential-Rate-Plan>

San Diego Gas & Electric 2018 Residential Rates:

<https://www.sdge.com/total-electric-rates>

Los Angeles Department of Water and Power 2018 Residential Rates:

https://www.ladwp.com/ladwp/faces/wcnav_externalId/a-fr-elecrate-schel

SMUD 2018 Residential Rates:

<https://www.smud.org/en/Rate-Information/Residential-rates>

2019 CBECC-Res, Residential Building Simulation Software:

<http://www.bwilcox.com/BEES/BEES.html>

[2019 Reference Appendices – JA11, JA12, and Others:](#)

http://www.energy.ca.gov/title24/2019standards/rulemaking/documents/2018-05-09_hearing/2019_Reference_Appendices.php

[California Public Utilities Commission \(CPUC\) Energy Efficiency Strategic Plan:](#)

<http://www.cpuc.ca.gov/General.aspx?id=4125>

Appendix D – Eligibility Criteria for Radiant Barriers, Section RA4.2.1

Radiant barriers shall meet specific eligibility and installation criteria to be modeled by any approved compliance software and receive energy credit for compliance with the Building Energy Efficiency Standards for low-rise residential buildings.

The emittance of the radiant barrier shall be less than or equal to 0.05 as tested in accordance with ASTM C1371 or ASTM E408.

Installation shall conform to ASTM C1158 (Standard Practice for Installation and Use of Radiant Barrier Systems (RBS) in Building Construction), ASTM C727 (Standard Practice for Installation and Use of Reflective Insulation in Building Constructions), ASTM C1313 (Standard Specification for Sheet Radiant Barriers for Building Construction Applications), and ASTM C1224 (Standard Specification for Reflective Insulation for Building Applications), and the radiant barrier shall be securely installed in a permanent manner with the shiny side facing down toward the interior of the building (ceiling or attic floor). Moreover, radiant barriers shall be installed at the top chords of the roof truss/rafters in any of the following methods:

- (a) Draped over the truss/rafter (the top chords) before the upper roof decking is installed.
- (b) Spanning between the truss/rafters (top chords) and secured (stapled) to each side.
- (c) Secured (stapled) to the bottom surface of the truss/rafter (top chord). A minimum air space shall be maintained between the top surface of the radiant barrier and roof decking of not less than 1.5 inches at the center of the truss/rafter span.
- (d) Attached [laminated] directly to the underside of the roof decking. The radiant barrier shall be laminated and perforated by the manufacturer to allow moisture/vapor transfer through the roof deck.
- (e) In addition, the radiant barrier shall be installed to cover all gable end walls and other vertical surfaces in the attic.

For Prescriptive Compliance: The attic shall be ventilated to:

- (a) Provide a minimum free ventilation area of not less than one square foot of vent area for each 300 ft² of attic floor area.
- (b) Provide no less than 30 percent upper vents.
- (c) Ridge vents or gable end vents are recommended to achieve the best performance. The material should be cut to allow for full airflow to the venting.

- (d) The product shall meet all requirements for California certified insulation materials [radiant barriers] of the, Bureau of Electronic and Appliance Repair, Home Furnishings and Thermal Insulation, as specified by CCR, Title 24, Part 12, Chapter 12-13, Standards for Insulating Material.
- (e) The use of a radiant barrier shall be listed in the Special Features and Modeling Assumptions listings of the Certificate of Compliance and described in detail in the Residential ACM Manual Conform to the radiant barrier manufacturer's instructions.

Appendix E

NATURAL GAS APPLIANCE TESTING (NGAT) STANDARDS

The NGAT standards, "Natural Gas Appliance Testing (NGAT) Standards", are found in Section 24 of the "California Installation Standards" manual; edition dated July 1, 2012. A copy may be obtained from contacting:

James E. O'Bannon

Richard Heath and Associates

1390 Ridgewood Drive, Suite 10

Chico, CA 95973

Phone: (530) 892-2460

Fax: (530) 892-2825

email: jim@rhainc.com

Appendix F - Field Verification of Zonally Controlled Systems

References: §150.0(m)13C, §150.1(c)13, JA1: Glossary: **ZONAL CONTROL**, RA 3.1.4.6

F1.1 Introduction/Scope

Zonally controlled systems are usually installed primarily for improved comfort, not improved energy consumption. Recent studies have shown that zonally controlled cooling systems that utilize bypass ducts or that substantially reduce the airflow across the coil when zone dampers close can actually use more energy. Because of this, HERS raters are required to evaluate these systems to ensure that it is consistent with what was modeled and what appears on the CF1R form.

One type of zonally controlled forced air system utilizes motorized zone dampers in the supply ducts to send supply air from a single air handler to different zones, as needed, rather than sending air to the entire area served by that system. These require multiple thermostats or temperature sensors in each of the zones. The number of zones can be two or more. Two-zone systems are by far the most common. The most common application of this type of system is in two story homes served by a single forced air system. The tendency for air to stratify, along with substandard duct design, causes comfort issues that can often be overcome by zonal control.

Note that dampers may also be installed on the return ducts, but are not required for the system to be considered a zonally controlled system.

Problems with this type of zonally controlled systems arise from the excess air pressure that occurs at the air handler fan when one or more of the zone dampers close and restrict airflow to just a portion of the supply duct system. One strategy is to simply let the pressure increase, which substantially reduces airflow across the cooling coil or heat exchanger. Another is to install a bypass duct that allows the excess air to “short circuit” from the supply side back to the return side. This causes problems by sending excessively hot air (heating mode) or excessively cold air (cooling mode) back into the system.

An alternative approach is to send the “excess air” back into conditioned space rather than directly back into the return air. These are not considered bypass ducts if the air has a chance to mix with house air in a way that does not substantially change the return air temperatures. The area in the home where the excess air is sent to is referred to as a “dump zone”. These dump zones will generally be over conditioned by this excess air and are usually unoccupied portions of the home, such as hallways or vaulted ceiling areas above the occupied zones. This design may lose some of the comfort benefits of a zonally controlled system.

Note that zonal control can be also achieved by using two separate systems, sized appropriately for each zone. These act independently and do not need zone dampers. These also do not require bypass dampers or other strategies to handle the excess air. For example, zonal control can be achieved in a two story home by installing a single system with zone dampers that separately control air to the upstairs and downstairs; or it can be achieved by installing two small systems, one dedicated to the first floor and one

to the second floor. Assuming that the house can be adequately served by a single large system, the first approach generally costs less.

If it is discovered that a zonally controlled forced air system is installed but not claimed for credit, it needs to be reported to the HERS provider (registry). Because zonally controlled systems can be an energy penalty, they need to be correctly modeled when installed.

F1.2 Summary of Requirements:

Prescriptive compliance approach –

1. Zonally controlled systems are not required, but if installed must meet mandatory AF/FE requirements (slightly different test methods for single speed and variable speed compressors)
2. Bypass ducts/dampers are NOT allowed.

Performance compliance approach –

1. Zonally controlled systems must be modeled if installed.
2. Bypass dampers allowed only if modeled.
3. Dual speed/multi speed condensers may also qualify for a credit (reduced penalty) and if modeled, must be installed.

Note: when a feature is “modeled” using the performance compliance approach it will appear on the certificate of compliance.

F1.3 Identifying Zonally Controlled Systems in the Field

The following are characteristics of most zonally controlled systems that utilize dampers. Not all of these items need to be apparent for the system to be considered zonally controlled. Final determination may require consulting with the installer, designer and system manufacturer.

1. Motorized or actuated zone dampers on the supply ducts. These can be one or more large dampers in or near the supply plenum or they can be one damper for each supply outlet (register). See diagrams below.
2. Multiple thermostats or temperature sensors in area served by a single system. The most common two zone systems utilize ordinary thermostats for each zone. Some systems have a single master thermostat with small temperature sensors in each zone.
3. A control board on or near the air handler with low voltage wires going to the thermostats/temperature sensors and to each damper. Low voltage wires will also connect the control board and the main air handler control board. See photos below.
4. Bypass duct and damper. This will be a duct connecting the supply end directly to the return end. On the supply side it will connect after the coil and before the zone damper(s), usually off of the supply plenum. On the return side, it can either connect directly to the side of the return end of the furnace, near the return end of the furnace in a return plenum, or as far away as a return grill boot. Some sort of automatic damper will control airflow through this duct. When all zones are calling for cooling (all zone dampers open), the bypass damper should be fully closed.

When one or more zone dampers close, the damper should open partially or fully as needed to reduce the supply plenum pressure. This is commonly achieved by a barometric bypass damper. Barometric dampers are held closed by an adjustable weight. When enough pressure builds up on one side of the damper, it overpowers the weight and opens the damper. See diagram below. Another strategy is to use a motorized damper.

F1.4 Identifying Multi-Speed/Variable-Speed Condensers

Most condensers operate at a single speed and capacity and either run for longer or shorter periods of time during hotter or cooler weather, respectively. Short run times (aka, short cycling) reduce efficiency. Multi-speed condensers typically have a high and low speed. This can be accomplished by two separate compressors inside a single condenser, or by a single dual-stage compressor. During cooler weather (aka, part load times) the condenser will run in low speed for longer run periods. When needed, the condenser can run in high speed.

Variable-speed condensers are not limited to just high and low speeds. They can gradually ramp from lowest to highest speeds as needed.

There are several features that can indicate that a condenser is multi-speed. These include:

1. Product tags, labels and marketing names that indicate two-stage, dual-stage, multi-stage, etc.
2. Two compressors observed by looking down through the condenser fan.
3. High and low capacities or nominal tonnages indicated on nameplate.

The only definitive way to determine if the condenser is multi-speed or variable speed is to record the make and model number and find the manufacturer's specifications.

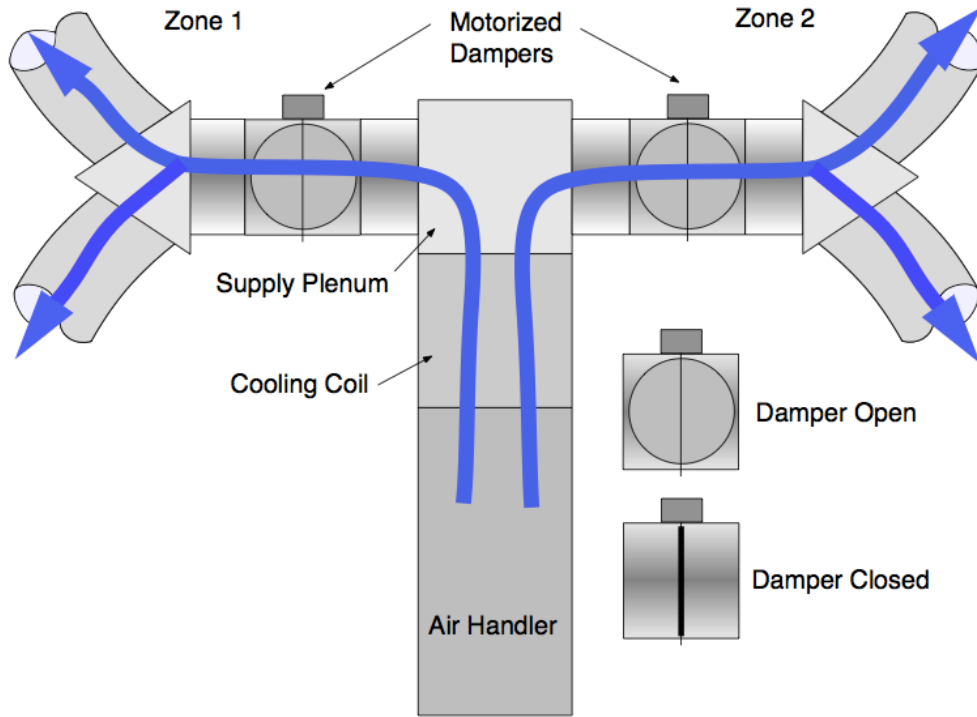

This diagram shows a common two-zone, two-damper system with both zones open (i.e., both zones are calling for cooling).

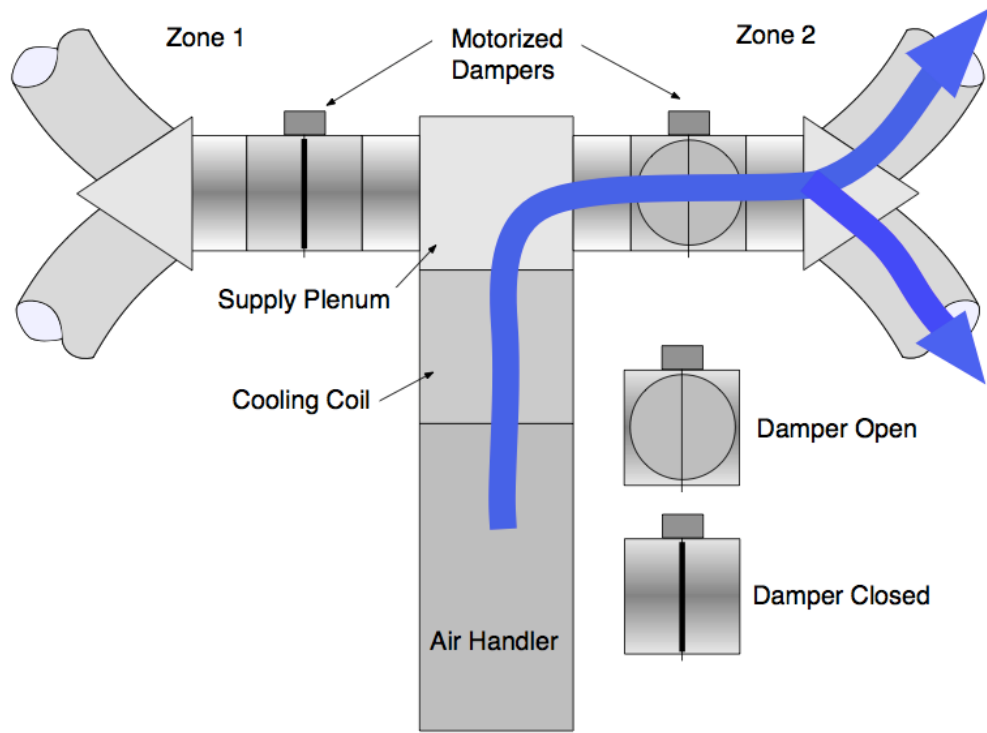

This diagram shows a common two-zone, two-damper system with zone 2 open (i.e., only zone 2 is calling for cooling).

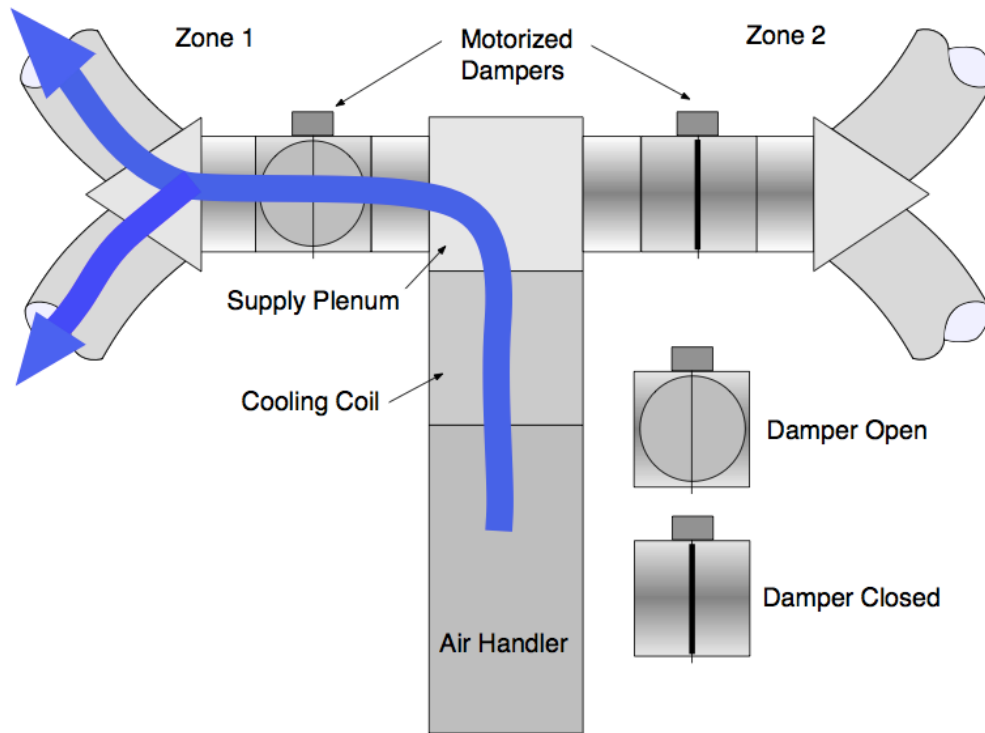

This diagram shows a common two-zone, two-damper system with zone 1 open (i.e., only zone 1 is calling for cooling).

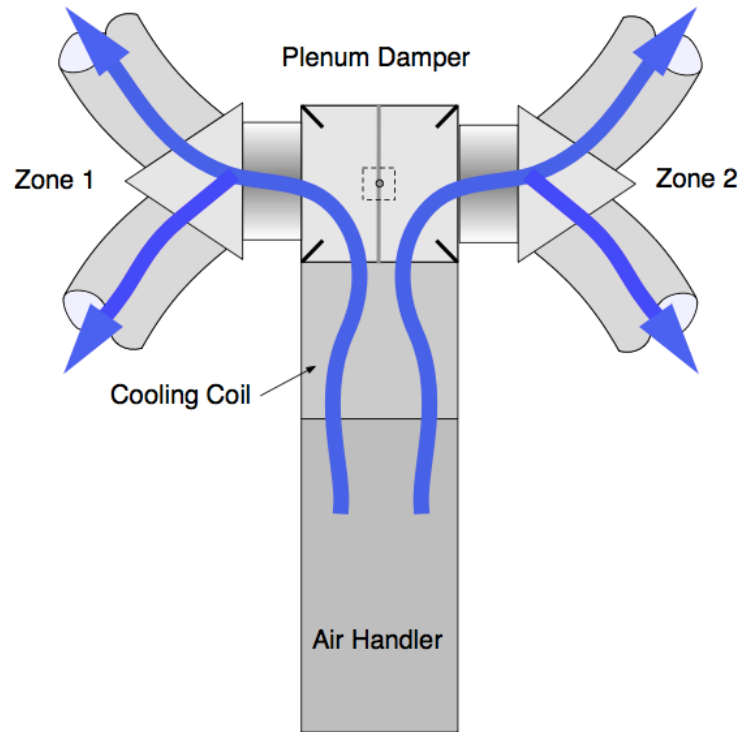

This diagram shows a common two-zone, single-damper system with both zones open (i.e., both zones are calling for cooling).

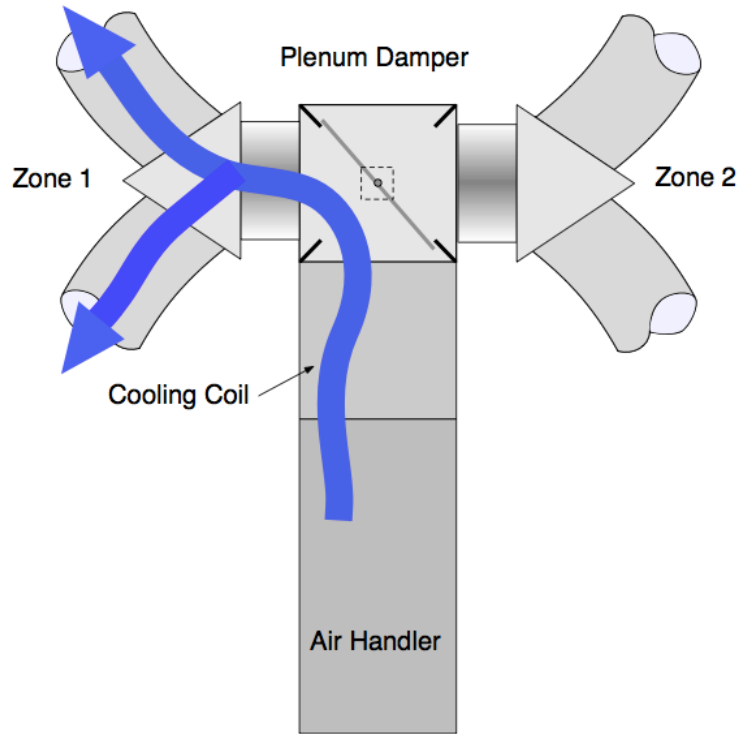

This diagram shows a common two-zone, single-damper system with zone 1 open (i.e., only zone 1 is calling for cooling).

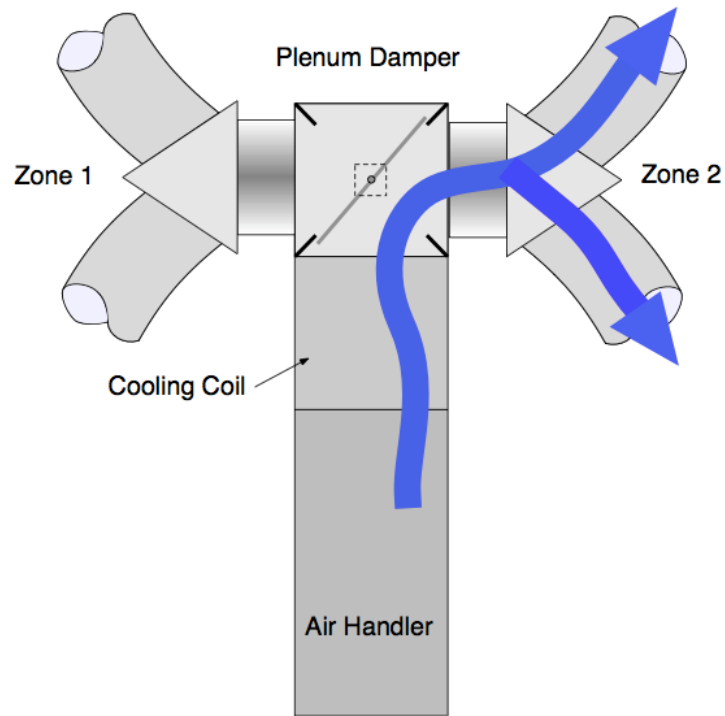

This diagram shows a common two-zone, single-damper system with zone 2 open (i.e., only zone 2 is calling for cooling).

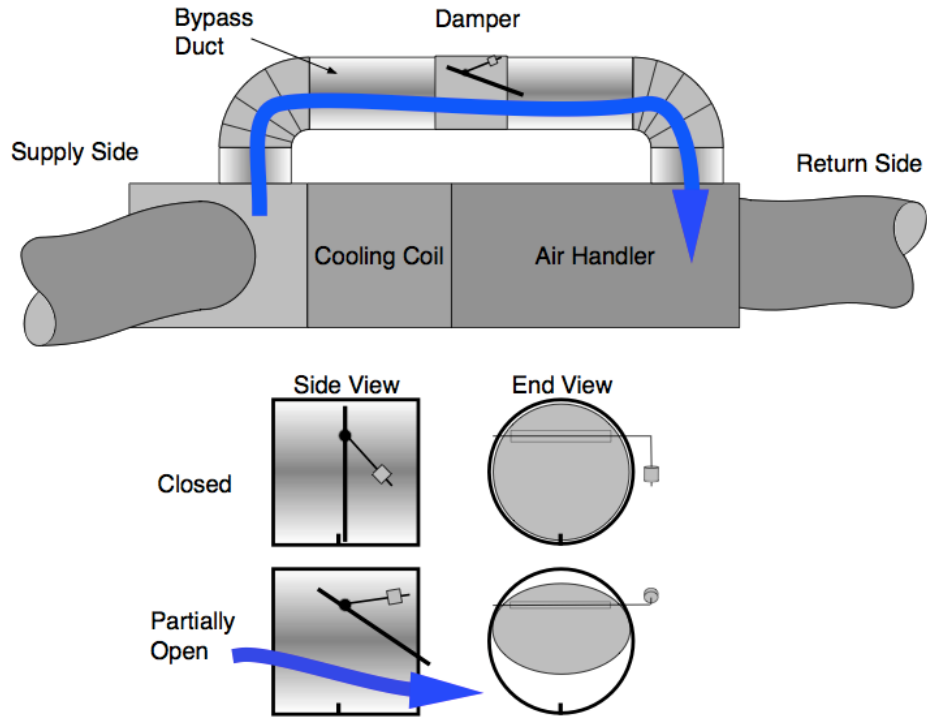

This diagram shows a common bypass duct/damper strategy. The bypass duct is sheet metal (which should always be insulated) and the damper is a barometric type. The details show how the damper opens when air pressure builds up against the adjustable weight. Sending heated or cooled air back into the space conditioning equipment can cause problems and reduce efficiency.

These photos show two examples of zonal control control-boards.

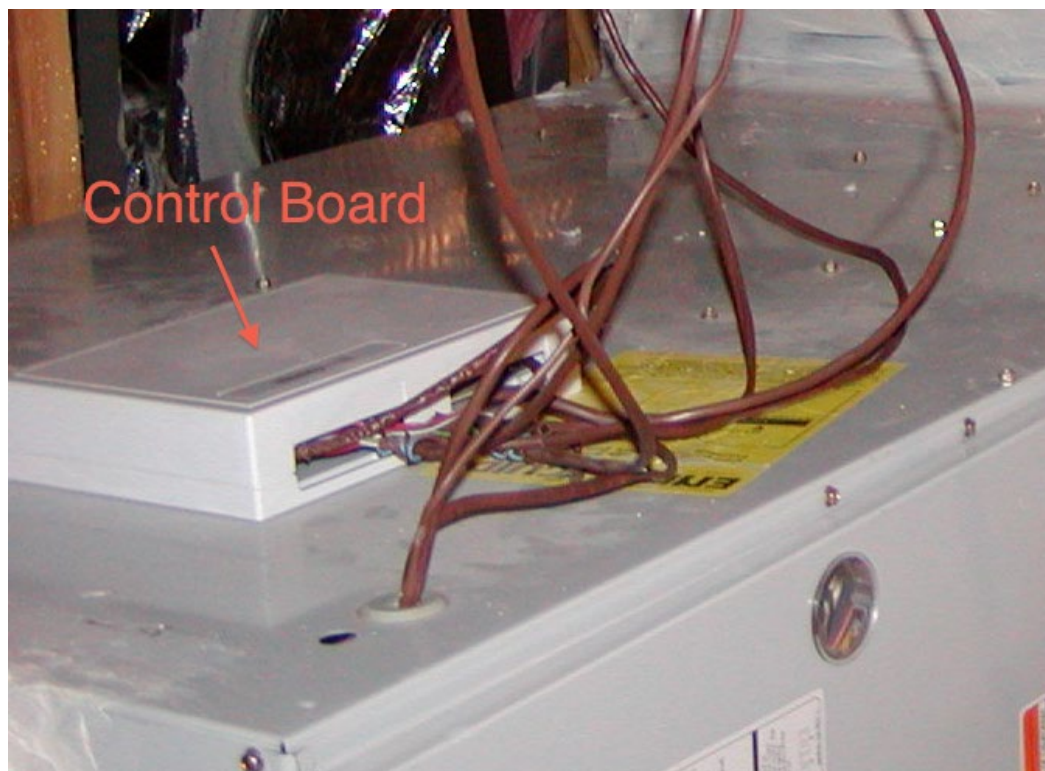

F1.5 References:

JA1: Glossary

ZONAL CONTROL is the practice of dividing a residence into separately controlled HVAC zones. This may be done by installing multiple HVAC systems that condition a specific part of the building, or by installing one HVAC system with a specially designed distribution system that permits zonal control. The Energy Commission has approved an alternative calculation method for analyzing the energy impact of zonally controlled space heating and cooling systems. To qualify for compliance credit for zonal control, specific eligibility criteria specified in the Residential ACM Manual must be met.

§150.0(m)15. **Zonally Controlled Central Forced Air Systems.** Zonally controlled central forced air cooling systems shall be capable of simultaneously delivering, in every zonal control mode, an airflow from the dwelling, through the air handler fan and delivered to the dwelling, of greater than 350 CFM per ton of nominal cooling capacity, and operating at an air-handling unit fan efficacy of less than 0.58 W/CFM as confirmed by field verification and diagnostic testing in accordance with the procedures specified in Reference Residential Appendix RA3.3.

EXCEPTION to 150.0(m)15: Multi-speed compressor systems or variable speed compressor systems shall demonstrate compliance for airflow (cfm/ton) and fan efficacy (Watt/cfm) by operating the system at maximum compressor capacity and maximum system fan speed and with all zones calling for conditioning.

§150.1(c)13. **HVAC System Bypass Ducts.** Unless otherwise specified on the Certificate of Compliance, bypass ducts that deliver conditioned supply air directly to the space conditioning system return duct airflow shall not be used. All zonally controlled forced air systems shall be verified by a HERS Rater utilizing the procedure in Reference Residential Appendix Section RA3.1.4.6 to confirm compliance with 150.1(c)13.

RA 3.1.4.6 Verification of Prescriptive Bypass Duct Requirements for Zonally Controlled Forced Air Systems

When a zonally controlled forced air system is installed, the following shall be verified to determine compliance as required by Energy Standards §150.1(c)13:

1. A visual inspection shall confirm that bypass ducts that deliver conditioned supply air directly to the space conditioning system return duct airflow are not used; or
2. If the Certificate of Compliance indicates an allowance for use of a bypass duct, the bypass duct shall conform to the specifications given on the Certificate of Compliance.

If the zonally controlled system meets one of these criteria, the system complies. Otherwise the system does not comply.

Appendix G

Verification of the Existing Features of a Home for Existing + Addition + Alteration Performance Approach

When adding to or altering an existing home, compliance credit can be taken for upgrading existing features by using the performance approach when the existing features are verified by a qualified HERS rater prior to registration of the certificate of compliance (CF1R).

The performance approach provides a means to trade off against features that may not meet the prescriptive requirements, such as exceeding the allowed maximum glass area, by demonstrating that the project (proposed design) achieves the same level of efficiency as it would if it were built to the prescriptive requirements (standard design). The standard design is a hypothetical building with prescriptive requirements from Table 150.1-A or 150.1-B that sets the target energy budget for the proposed project.

The Existing + Addition + Alteration approach gives further credit for upgrading existing features. It does this by modifying the standard design for an altered building feature to match the requirements specified in Section 150.2, particularly Table 150.2-C. The greater the efficiency of the altered building feature is relative to the existing energy efficiency, the greater the compliance credit will be. Third-party verification of the features prior to the construction is required to achieve the maximum compliance credit.

The proposed design is calculated using the actual energy efficiency values of the existing unaltered components of the existing building, and the proposed values of the altered components, plus the proposed addition's features. Each building component must be modeled with one of the following classifications to determine the standard design:

1. "Existing" – building components that remain unchanged (e.g., exterior walls in the existing portion of the building that will not be altered).
2. "Altered" – existing building components that are being changed (e.g., added roof insulation, or a furnace that is being replaced).
3. "New" – building components that do not exist prior to the construction work (e.g., new walls added to create the addition). This includes building components in a previously unconditioned space being converted to conditioned space.

All of these building components determine how the standard design is calculated. Existing features are modeled the same in both the proposed and standard designs. New

features are modeled in the standard design according to prescriptive requirements, Table 150.1-A or Table 150.1-B. Altered features are modeled in the standard design according to Table 150.2-C.

There are two columns in Table 150.2-C. One column defines how the standards design is calculated for altered components when the existing features are not verified by a HERS rater. The other column indicates how the standards design is calculated when the existing features are verified by a HERS rater prior to construction.

For the building to comply, the proposed design (proposed project details as modeled) must be equal to or less than the standard design. When a feature in the proposed design is better than the standard design, it receives a compliance credit that can be used to trade against less efficient features. For example, without third-party verification, windows to be altered are assumed to have 0.40 U-factor and 0.35 solar heat gain coefficient (SHGC). With HERS verification, if the existing windows are single pane metal framed, they are assumed to have 1.28 U-factor and 0.80 SHGC, resulting in substantial potential compliance credit if the new windows meet current prescriptive requirements of 0.30 U-factor and 0.23 SHGC.

Example:

Consider the house in Figure G-1 in climate zone 12. The shaded area is the addition. Some windows and walls are removed to build the addition. These are ignored. The existing home has the following features:

1. Single-pane metal framed windows
2. 2x4 R-0 walls, and R-19 attic insulation
3. AFUE 75 furnace

Figure G-1 – The Proposed Addition and Alterations

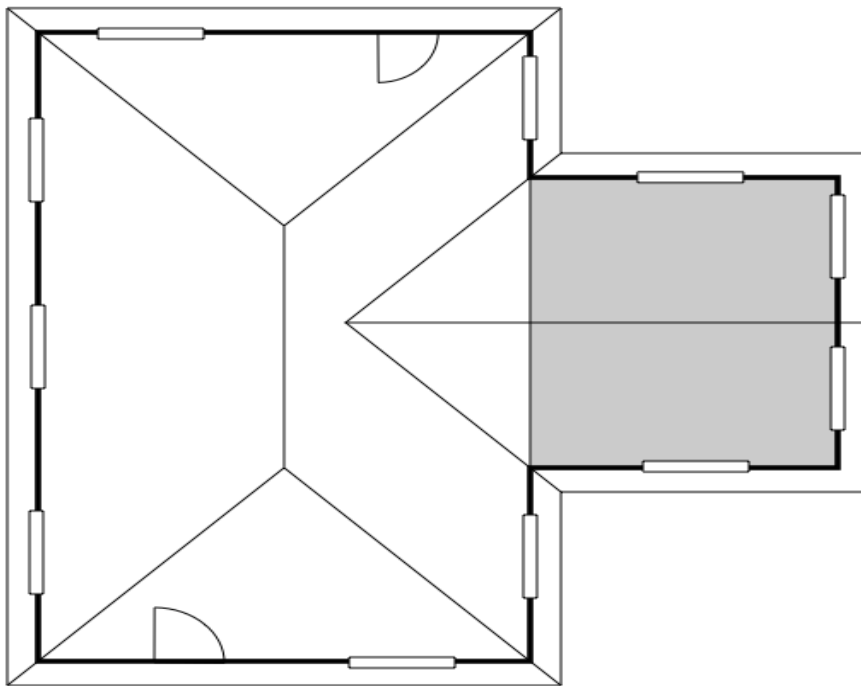

Table G-1

Component	Status	Proposed	Standard Design w/o verification	Standard Design w/verification
Attic ¹	Existing/Altered	R-38	R-22 (U=0.043)	R-19 (U=0.049)
	New	R-38	R-38	R-38
Walls ²	Existing/Altered	R-15	R-13 (U=0.102)	R-0 (U=0.356)
	New		R-19+4	R-19+4
Window	Existing/Altered	0.30/0.23	0.40/0.35	1.28/0.80
	New	0.30/0.23	0.30/0.23	0.30/0.23
Furnace	Existing/Altered New	0.92	0.80	0.75
1. Depending on the size of the addition, roof deck insulation may be included in the standard design. 2. Under some conditions (unconditioned existing space converted to conditioned space, or wall extensions), the standard design may not include continuous insulation. See Chapter 9 for more detail.				

Part of the construction work includes replacing all of the windows with low-E vinyl windows to match the new windows in the addition, adding insulation to the existing attic and replacing the existing furnace.

For the proposed design, none of the attic is modeled as existing because insulation is being added to the existing building (“altered”), and the attic in the addition is “new.” None of the windows are modeled as existing (unless any are not replaced). Replaced windows in the existing building are “altered” and the windows in the addition are “new.” The furnace, even though it is new, is modeled as “altered” because it is replacing an existing heating system. The walls, windows, and other components that are removed as part of the addition and alterations are ignored.

Table G-1 illustrates how the proposed features and the standard design features are calculated, depending on whether there is HERS verification of the existing conditions.

The HERS rater must complete the verification of the existing conditions in order to register the certificate of compliance (CF1R).

HERS raters follow the protocols for a Whole-House Home Energy Rating (WHHER) when verifying existing conditions. The HERS rater is trained by a HERS provider to verify the existing conditions of the home consistent with Energy Commission approved HERS provider training for the verification requirements specified in Table 150.2-C. The Data Registry will generate a CF3R-EXC-20-H compliance document based on the output from the performance compliance software. The CF3R-EXC-20-H will list the features of the existing conditions that must be field verified by the HERS rater. A registered CF3R-EXC-20-H that agrees with the existing conditions input for the proposed building is required by the HERS Registry as a prerequisite the registration of the CF1R for the project.

The WHHER protocols are established by the HERS Technical Manual (CEC-400-2008-012). Appendix A of that document details the protocols for verification of each component. Raters must follow all Energy Commission approved procedures established by the HERS provider. The HERS Technical Manual can be downloaded from:

<http://www.energy.ca.gov/title24/2019standards/index.html>

Appendix H - Demand Responsive Controls

This appendix to the residential compliance manual addresses the demand responsive (DR) control requirements in the 2019 Building Energy Efficiency Standards (Energy Standards).

Demand response is an increasingly important function of buildings as distributed energy resources become more common and customers have access to time of use electricity rates and incentive programs designed to encourage demand side optimization. Demand response occurs on a range of timescales, from seconds to seasons, and represents any demand change in response to grid or economic needs. In addition to current time of use electricity rates, utilities in the future will likely connect electricity costs to high frequency fluctuations in both the supply and demand for electricity. Appropriate demand responsive controls allow building operators to maintain the quality of services a building provides and reduce the total cost of energy by automating a building's response to changes in electricity rates.

The following definitions from §100.1 are relevant to the DR control requirements:

Demand response is short-term changes in electricity usage by end-use customers, from their normal consumption patterns. Demand response may be in response to:

- a. Changes in the price of electricity; or
- b. Participation in programs or services designed to modify electricity use.
 - i. In response to wholesale market prices.
 - ii. When system reliability is jeopardized.

Demand response period is a period of time during which electricity loads are modified in response to a demand response signal.

Demand response signal is a signal that indicates a price or a request to modify electricity consumption for a limited time period.

Demand responsive control is an automatic control that is capable of receiving and automatically responding to a demand response signal.

The DR control requirements ensure that the building is DR capable (i.e., capable of responding to a DR signal). The decision to employ demand response is up to the building owner or manager, in coordination with their utility company and/or a governing authority. A building that is capable of receiving and responding to a demand response signal is sufficient to meet the requirements of the Energy Standards. DR-capable is described as follows:

DR-capable: A building is capable of DR when the building has loads that can be curtailed, DR controls are installed, and the controls have been programmed/configured so the test control strategy that is defined in the building code can be deployed (note: the DR controls can be programmed with additional control strategies).

DR-enabled: A building's DR is enabled when the connection between the entity that sends the DR Signal and the DR control in the building has been tested and communications have been allowed or "enabled".

DR-enrolled: A building is enrolled when the building owner/occupant has enrolled in a DR program (note: this may include updating the settings or programming of the DR controls to better match the terms of the program).

The requirements for DR controls only apply if the controls are used to comply with the building standards (i.e., DR Thermostats or a heat pump water heater). If DR control are installed voluntarily and do not contribute to compliance with minimum code requirements, they do not need to adhere to requirements in Title 24, Part 6. (For residential dwellings, DR controls are only required as a part of specific Exceptions to HVAC and Solar Ready requirements.)

1. Communications Requirements for DR Controls

§110.12(a)1-3

There are two main communication requirements that apply to all DR controls:

1. The control must, at minimum, be able to understand a signal sent using OpenADR; and
2. The control must, at a minimum, be able to receive signals over one of the specified paths.

These are minimum requirements, meaning that the control can have (and use) additional communication features provided that the required features are included.

1.1 Communication With Entity That Initiates DR Signal

§110.12(a)1

DR controls must have the capability of communicating with the entity that initiates a DR signal by way of an OpenADR certified virtual end node (VEN).

The OpenADR 2.0 protocol is the primary open-standard protocol used in the California market. It implements a profile within the Organization of Structured Information Standards (OASIS) Energy Interoperation information and communication model that defines two types of communications entities – virtual top nodes (VTNs) and virtual end nodes (VENs). VTNs are information exchange servers typically operated by utilities or third-party providers and can dispatch events. VENs are the recipients of DR payloads and are typically the gateway or end-use devices installed at customer facilities throughout a dispatcher's territory. See OpenADR Alliance's website (<http://www.openadr.org/>) for more information about OpenADR certified VENs.¹

There are two ways to comply with the OpenADR certified VEN requirement:

¹ The OpenADR Alliance's Frequently Asked Questions web page is a helpful resource: <http://www.openadr.org/faq>.

Option A: Install an OpenADR 2.0a or 2.0b certified VEN within the building as part of the DR control system (§110.12(a)1A)

If complying using Option A (§110.12(a)1A), the designer of the DR control system(s) must select a VEN that the OpenADR Alliance has certified as being compliant with the OpenADR 2.0a or 2.0b specification.² The OpenADR Alliance maintains a list of certified VENs (<https://products.openadr.org/>). If using Option A, the certified VEN must be installed inside the building at the time of inspection. The building can comply if the DR control system has a certified VEN that is incorporated into a networked system of devices such that the single VEN communicates control strategy information to multiple devices in the network (e.g., a gateway system), or if each device (e.g., thermostat) in the building is itself a certified VEN.

Option B: Install a DR control system that has been certified to the Energy Commission as being capable of communicating with an OpenADR 2.0b certified VEN (§110.12(a)1B)

If complying using Option B (§110.12(a)1B), the designer of the DR control system(s) must select a DR control system that the Energy Commission has approved for the certified list of DR control systems. The Energy Commission maintains a list of certified products and instructions on how manufacturers can certify products on their website: http://www.energy.ca.gov/title24/equipment_cert/. If using Option B, the manufacturer of a DR control system must submit documentation to the Energy Commission confirming that the DR control system is capable of communicating with an OpenADR 2.0b certified VEN.

Option B requires that the manufacturer of the DR control system certify to the Energy Commission that the control system is capable of communicating with an OpenADR 2.0b certified VEN. This requirement does not mean that the DR control system must be connected to a 2.0b certified VEN. When the DR control system is connected to a VEN, it can be connected to either a 2.0a or 2.0b certified VEN.

As discussed in Section 1.3 below, the DR control system must comply with Option A or Option B, but the control system can also include features that allow the control system to use other communications protocols. It should also be noted that if using Option B, the DR control system is capable of communicating with an OpenADR 2.0b certified VEN, but that does not mean that DR programs have to use OpenADR 2.0b in their programs.

When specifying DR control systems, it is recommended that the controls designer check to see which DR programs are currently available in the area and specify controls that are both compliant with Title 24, Part 6, and eligible for the area's DR programs.

1.2 Communication Pathways

§110.12(a)2

² The OpenADR 2.0a and 2.0b specifications are available on the OpenADR Alliance's website: <http://www.openadr.org/specification>.

DR controls must be capable of using one or more of the following to communicate (i.e., send and receive signals):

- Wi-Fi: for more information see the Wi-Fi Alliance website: <https://www.wi-fi.org/>.
- ZigBee: for more information see the ZigBee Alliance website: <http://www.zigbee.org/>.
- BACnet: for more information see <http://www.bacnet.org/>.
- Ethernet; or
- Hard-wiring.

As described in Section 1.3 below, DR control systems can also support additional communications protocols.

1.3 Additional Communication

§110.12(a)3

Section 110.12(a)3 explicitly states that DR controls are allowed to use communications protocols in addition to the ones required above. This means that the control can communicate with entities that initiate DR signals using different protocols, including but not limited to proprietary protocols and other non-proprietary protocols like the American National Standards Institute (ANSI) / Consumer Technology Association (CTA) Standard for Modular Communications Interface for Energy Management (ANSI/CTA-2035-A), provided that it complies with one of the options for OpenADR compatibility. Similarly, the DR control system is allowed to use other physical means of communication provided at least one of the specified methods is supported.

The DR control may use any of its available communication features to participate in DR programs.

2. Other Requirements for DR Controls

2.1 Perform Regular Functions When Not Responding to DR Events

§110.12(a)4

Controls that include demand response with other control functions must perform their regular control functions, as required by other parts of the building code, when the control is not performing DR-related functions. This includes when the controls are not responding to a DR event, when the DR functions are not enabled (see description of DR-enabled in the introduction to this chapter of the compliance manual) or when the DR controls are temporarily disabled or disconnected (e.g., due to a network outage).

For example, if the building owner/operator never enables the DR controls or enrolls in a DR program, the building control system(s) must comply with all other applicable controls requirements and continue to provide those control functions. Similarly, if the building owner/operator does enable the DR controls and is enrolled in a DR program, the building control system(s) must perform as required by the applicable building code requirements whenever the building is not participating in a DR event. The DR control functionality is an additional control feature on top of all of the other required building controls.

2.2 Certification Requirements for DR Thermostats

§110.12(a)5

Residential DR thermostats, also called Occupant Controlled Smart Thermostats (OCSTs), must comply with the technical specifications described in Joint Appendix 5 (JA5). According to the requirement in JA5, manufacturers of DR thermostats must submit documentation to the Energy Commission to certify that the thermostat meets the code requirements. See the Energy Commission's website for a list of certified products and for instructions to manufacturers that wish to certify products:

http://www.energy.ca.gov/title24/equipment_cert/.

3. DR Controls for Power Distribution Systems

§130.5(e)

DR controls for HVAC equipment may be installed at the circuit level; in this case, the DR controls must meet the complete requirements for DR thermostatic controls.

4. Energy Management Control Systems / Home Automation Systems

Required thermostatic and lighting control functions (including DR control functions) can be incorporated into and performed by an energy management control system (EMCS). Using an EMCS to perform these control functions complies with Title 24 provided that all of the criteria that would apply to the control are met by the EMCS.

A Home Automation System that manages energy loads (such as HVAC and lighting systems) is considered a type of energy management control system and, as such, can similarly incorporate the ability to provide required control functions.